

## The L6170A combines traditional reliability with tomorrow's technology.

For years, men who work on the water have relied on big, in-line, six cylinder diesels like the Luger 6170A. A big bore, high torque 23 liter engine that will work day and night without complaint.

Unlike the small bore, high speed V8-10-12 engines from some manufacturers, the 6170A embodies the original diesel philosophy of long life, safety, total dependability and low life-cycle costs. The longer it runs the more you save.

Its values may be old fashioned, but not its design. Based on an industrial duty block from Komatsu, a world leader in engine technology, it incorporates advanced features you won't find on any other engine.

## Put more technology in...

Features that maximize life and increase efficiency such as: Nodular iron pistons with dual circuit oil spray cooling. Individual, four valve cylinder heads. Replaceable wet cylinder liners. Liquid cooled turbocharger. Jacket water aftercoolers. Mechanical variable timing fuel injection. Dual fuel and oil filters. Coolant filter/conditioner. Optional front PTO (power take off) with an electric clutch. We put more in and then we...



## Take less power out.

Continuously rated at 700 horsepower, the L6170A gives the tug boat operator 2086 foot pounds of barge shoving torque at 1500 rpm. With a conservative hp/cid ratio of 0.5:1, it works without straining. Its 900 horsepower high output rating is only 29% above the continuous duty rating. This is an engine rated for the long haul, not stretched for the short run.

## Cut your fuel costs.

The L6170A's performance comes from superior engineering and proven mechanical operation. So does its remarkable fuel economy. With a specific fuel consumption rate going as low as 0.331 lbs/hp/hr, the L6170A will lower your operating costs and extend your vessel's working range. Compare the fuel curves on the back cover with any engine in its class. Then calculate the money an L6170A will save you on fuel bills.

## Compact, in-line size.

The L6170A is under 43 inches wide. Unlike wall-to-wall Vees, it gives you an engine room with elbow room. Easy to install too; with one exhaust and one cooling circuit.

## Electric clutch PTO for power out both ends.

With an optional front PTO, your Luger can power vessel's bow thrusters, alternators and other auxiliary equipment. It's more than an engine, it's a total marine power system.

HORSEPOWER	700 /1800 rpm Continuous
	800/2000 rpm Medium Duty
	900/2100 rpm High Output

## Easy to service.

Clean design eliminates trouble spots. Hoses, belts, rubber impellers and electronic gadgets have been engineered away. What's left is accessible and easy to maintain. Individual heads, wet liners and oil pan access doors allow one cylinder to be rebuilt without disturbing the rest. Per-hole parts costs are very competitive. And rebuilds are less painful since it has 6 cylinders instead of 8 or 12.

## Clean, quiet operation.

Internal oil lines and close tolerance machining eliminate oil leaks. Low load smoke is cut by "clean-burn" combustion design and jacket water aftercooling. Four cycle operation and vibration attenuation features make it quiet and smooth. In the engine room or on deck, the L6170A is easy to live with.

## Tested, tested, tested.

First the engine is dyno tested after marinization. Then the reverse gear is installed and it's run again. This testing is part of Luger's standard quality control program.

• Cast heat exchanger cooling expansion tank. No welds to break.

• Jacket-water cooled aftercooler. Thermostatic temperature control for less smoke.

• Dual spin-on fuel filters.

• Cupro nickel heat exchanger.

• Self-priming centrifugal sea-water pump with bronze impeller.

• Variable timing fuel injection control.

• Heavy duty welded steel mounting feet.

• Optional engine and gear oil change pump.

**L6170A** Service points are grouped on this side for ease of maintenance. Shown with heat exchanger cooling, optional pulley and oil change pump.

• Oil sump doors for in-boat rebuild.

• Bosch-type inline fuel injection pump with manual priming pump.

• Accessible lube oil fill and dip stick.

• Dual spin-on oil filters.

• Flywheel housing SAE 0 18 inch flywheel.

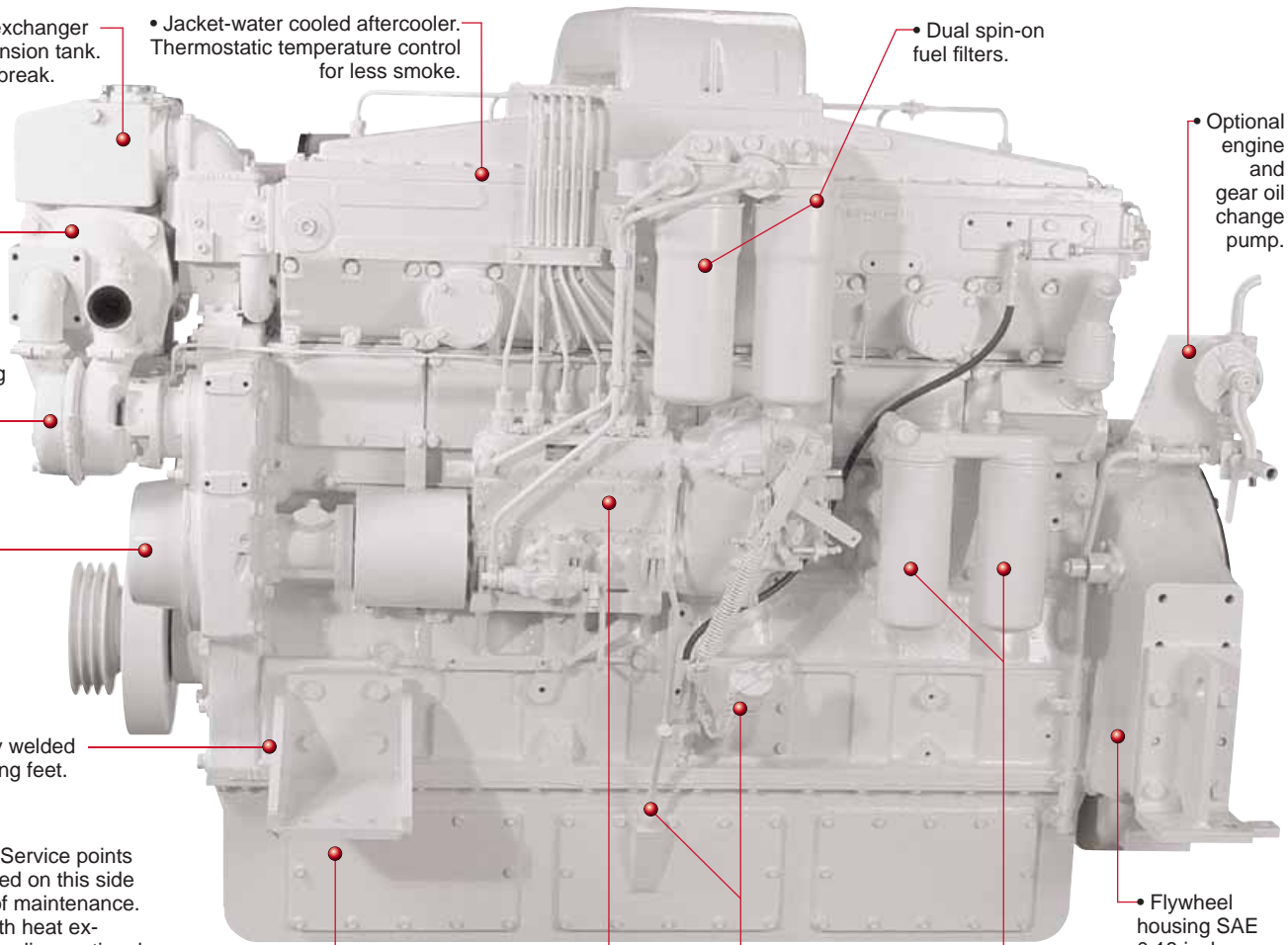

## Engine Block

- Komatsu six cylinder, 4 cycle, over-head valve, heavy duty, industrial diesel engine block with internal ribbing for strength.
- One-piece, forged steel crankshaft with 5.5 inch (140 mm) induction hardened journals for rigid crankshaft support.
- Large alloy steel connecting rods.
- Six individual cylinder heads simplify service. One cylinder can be rebuilt without disturbing the rest. Two intake ports produce optimum swirl for clean combustion. Short exhaust ports reduce heat loss and provide maximum energy to the turbocharger.
- Four valves per cylinder for superior breathing. Double valve springs for positive valve seating. Replaceable valve seats and guides.
- Replaceable wet cylinder liners for heat dissipation, longer life and lower rebuild costs. Liner



surface is Tuftride treated to prevent scuffing and lower oil consumption. Twin coolant inlets for uniform cooling and less cavitation.

- Pistons are one piece nodular cast-iron rather than aluminum. See feature box.
- Arm mount roller cam followers reduce friction and extend life of valve train.

## Cooling System

- Self venting, jacket-water cooling system available in single circuit keel cooled configuration (right) or heat exchanger configuration.
  - Heat exchanger gear driven, self-priming centrifugal sea-water pump with bronze impeller. No drive belt to fail. Tube type heat exchanger is cupro-nickel for long life and removable for easy cleaning. Zinc anodes help prevent electrolysis.
- One-piece, cast iron exhaust manifold is jacket-water cooled. No welds to fail. No gasketed connections between water



and exhaust passages reduce possibility of water entering the cylinders.

- Gear oil cooler in jacket-water circuit normalizes gear oil temperature. This reduces condensation, extends oil life and maintains oil temperature and viscosity for trolling valve operation.
- Spin-on coolant conditioner controls PH and filters out particulates.
- Remote expansion tank (below), standard on keel cooled engines, is shown with optional water level sensor. Heat exchanger engines have unit mounted cast aluminum expansion tank.
- Clean design eliminates hoses, clamps and leaks. Coolant connections are pipe with o-ring seals.
- Three thermostats for safety, quick warm ups and even temperature control.



## L6170A

Shown with heat exchanger cooling and optional front pulley.

- Turbocharger for improved performance and fuel economy. Jacket-water cooled turbine for safety.

- Cast-iron, liquid cooled, exhaust manifold.

- Thermostatic stainless steel, engine lube oil cooler.

- SAE "O" flywheel housing.

- Dual 24V, 10 HP starters. Air starting optional.

- Cupro-nickel gear oil cooler for long oil life and better lubrication.

- Tough, long-life, white IMRON<sup>®</sup> polyurethane paint.

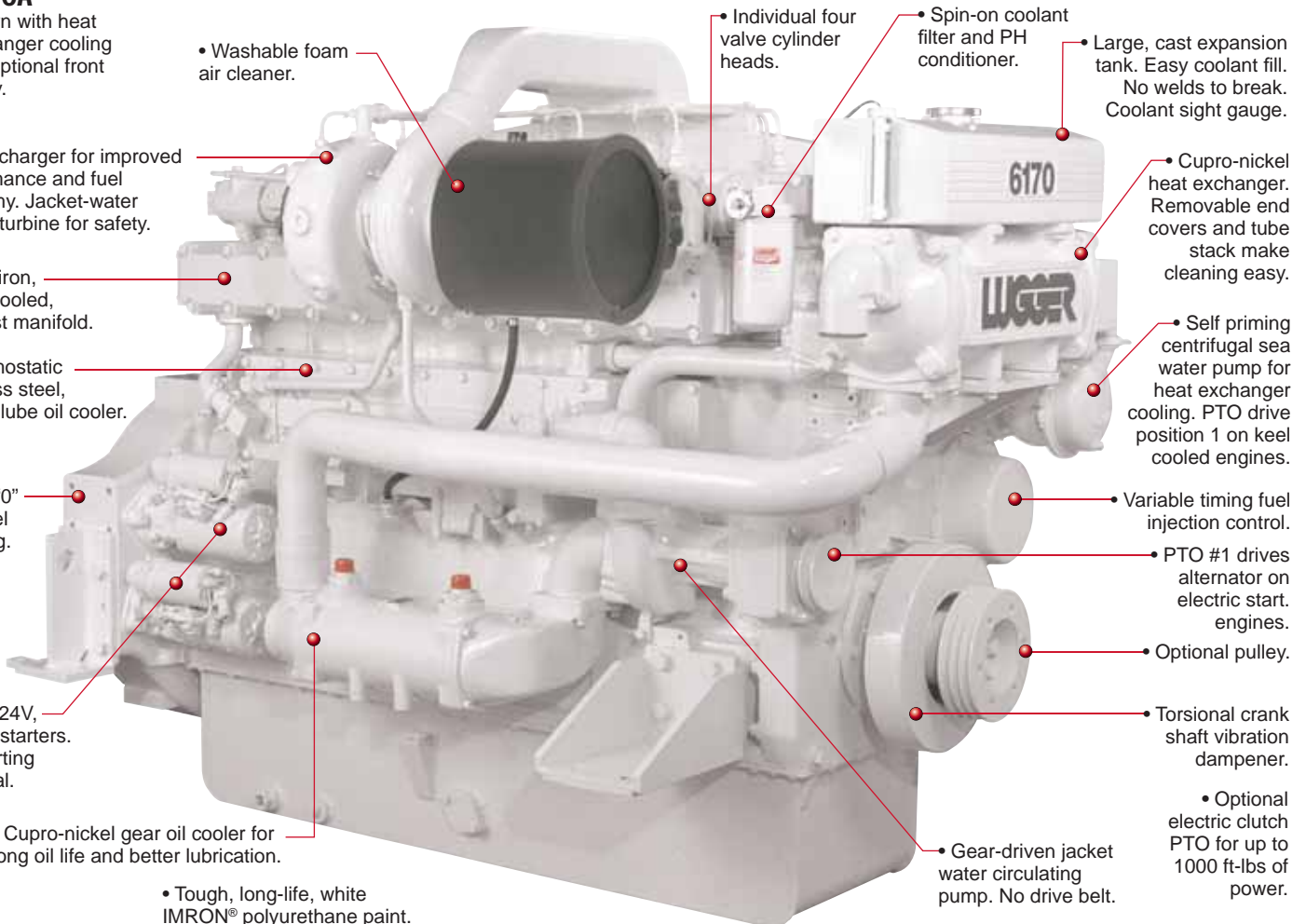

- Washable foam air cleaner.

- Individual four valve cylinder heads.

- Spin-on coolant filter and PH conditioner.

- Large, cast expansion tank. Easy coolant fill. No welds to break. Coolant sight gauge.

- Cupro-nickel heat exchanger. Removable end covers and tube stack make cleaning easy.

- Self priming centrifugal sea water pump for heat exchanger cooling. PTO drive position 1 on keel cooled engines.

- Variable timing fuel injection control.

- PTO #1 drives alternator on electric start engines.

- Optional pulley.

- Torsional crank shaft vibration dampener.

- Optional electric clutch PTO for up to 1000 ft-lbs of power.

- Gear-driven jacket water circulating pump. No drive belt.

# make a good engine block into a great marine engine.

## Air System

- Large capacity, plate-type aftercooler uses jacket water, not corrosive sea-water to control the intake air temperature. It warms air for low smoke starts. Under load it cools air for more efficient combustion and increased horsepower.
- Turbocharger is liquid cooled for safety.
- Cleanable foam air cleaner standard. Airsep® crankcase vent vapor trap/air filter system is optional.

## Fuel System

- Direct fuel injection for fuel economy.
- Inline Bosch-type injection pump is gear driven and force lubricated. High pressure for better fuel atomization.
- Variable injection pump timing system reduces low-load smoke.
- Bosch-type rebuildable injectors are placed in the center of the cylinder for the most efficient fuel spray pattern and increased fuel economy. Injectors fit in liquid cooled liner to control nozzle and head temperatures.
- Fuel system design is self venting and minimizes lube oil dilution.
- Dual spin-on fuel filter elements.
- Mechanical fuel transfer pump.

## Lubrication System

- Jacket-water, stainless steel, plate-type oil cooler with thermostat is built into block to eliminate hoses. Controls oil temperature to reduce power losses.
- Internal oil passages reduce leaks.
- Dual, full flow, spin-on oil filters.

## Electrical System

- 24 volt, negative ground, marine grade system includes two 7.5 kW (10 hp) starters and alternator.
  - Two standard control panels have square bezel instruments.
- Main panel** has: tachometer, hour meter, coolant temperature gauge, oil pressure gauge, DC volt meter, stop button, key switch with preheat function and gauge light rheostat. It also has warning lights and audible alarm for low oil pressure and high coolant temperature.



**Auxiliary panel:** turbo boost, gear oil pressure and exhaust temperature gauges.



- Engine and panel are prewired. 20 foot wire harness with water-resistant plugs std. Harness extensions are available.
- Preheaters for cold (0°F) starting.

## Other Features

- White polyurethane paint for long life finish and service visibility.
- Operator's and parts manuals.

## A Luger Exclusive: Nodular Iron Pistons



The L6170A is the only engine in its class with cast nodular iron pistons for longer life, efficiency and performance.

- Equal thermal expansion of the piston and liner allows a closer fit between them. Power loss past piston rings is reduced.
- Keystone shaped compression ring reduces carbon buildup during light load operation (1).
- Iron is stronger than aluminum. This allows the top compression ring to be closer to the piston crown minimizing the combustion dead zone (2) and increasing efficiency.
- Iron transfers heat evenly for long life.
- Tuftride treatment holds oil and helps prevent scuffing.
- Oil cooling gallery (3) in piston allows higher combustion temperatures for more power output per cubic inch, less exhaust smoke and more fuel efficiency.
- Massive wrist pin bearing surface (4).
- Less than 17 lbs. Strong not heavy.
- One piece piston can't come apart.
- Contoured combustion chamber (5) promotes air/fuel mixture to increase efficiency.

Cross section of Luger cast iron piston.

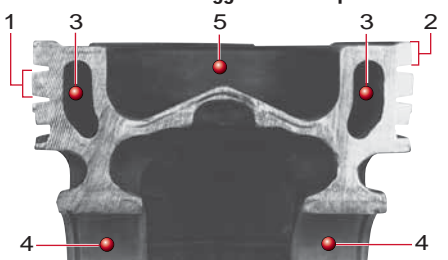

## L6170A Accessories and Options

Use these components to make your Luger into an integrated power system that fits your vessel's special needs.

- Flybridge instrument panel with 10 foot wire harness and easy to install plug-ins. Tachometer, coolant temperature gauge, oil pressure gauge, start and stop button, and gauge light rheostat. It also has warning lights and audible alarm for LOP/HWT.
- Engine mount or remote stop-start panel.



- 10, 20, 40 ft wiring harness extensions.

## Accessory drives:

run alternators, pumps, hydraulics, or power steering off your main engine.

- **Drive 1** runs 1.8 times crankshaft speed. Up to 3.5hp. 120mm one groove pulley. Drives sea water pump on HE engines.

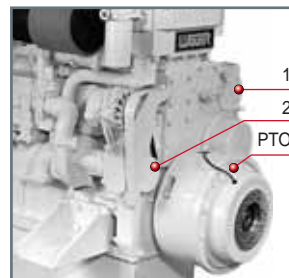

- **Drive 2** runs at crankshaft speed. 187 mm B-groove pulley up to 10 hp. Drives DC alternator on electric start engines.

## Front power take offs.

Take up to 1000 ft-lbs at 1800 rpm off the front of your L6170A with an SAE 3 or 4 adapter kit and one of these PTOs: Pump mount SAE-C spline 2 or 4 bolt pad. Pump mount SAE D/E spline. Both have a 24 volt electric clutch giving you hydraulic power at the touch of a button.



- 24 Volt, isolated ground DC system.

- 24 Volt alternators, standard or isolated ground: 35A, 75A or 100A.



- Dry exhaust: 8" dry exhaust elbow. 8" x 13.5" stainless steel exhaust compensators. Turbo outlet weld flange.

- Oil change pump for engine and gear.



- Racor fuel filters.

- Spare parts kits.

- Crankshaft pulley: 4-A/B grooves.

- Twin Disc or ZF marine gears. Trolling valves. Shaft couplings.



- Coolant level sensor.

- Chrome valve covers.

- Jacket water heater.

- Remote expansion tank (standard on keel cooled engines). Available with optional sight gauge/thermometer and low coolant level switch.

- Air-Sep® air filter system.



- Remote loud alarm LOP/HWT

- Vibration isolating flexible engine mounts. Set of 6.

- Right hand side oil filter.

## L6170A Specifications and Installation Data

Output Rating	CONTINUOUS	MEDIUM	HIGH OUTPUT
FWHP (kW)	700 (519)	800 (593)	900 (667)
Maximum RPM	1800	2000	2100
Cylinders / Configuration / Cycle	6 / Inline / 4	6 / Inline / 4	6 / Inline / 4
Displacement CID (ltr)	1413 (23.15)	1413 (23.15)	1413 (23.15)
Aspiration	<b>All Models:</b> Turbocharged - Aftercooled		
Bore x Stroke in (mm)	<b>All Models:</b> 6.69 x 6.69 (170 x 170)		
Cooling (General)			
Coolant circ pump flow - US gpm (lpm)	178 (674)	224 (848)	235 (889)
Heat rejection to jacket water - BTU-min	21,770	23,100	25,400
Cooling (Heat Exchanger)			
Jacket water system capacity - US gal (ltr)	<b>All Models:</b> 24.6 (38) engine only		
Raw water intake dia. - in (mm)	3 (76)	3 (76)	3 (76)
Raw water discharge dia. - in (mm)	3 (76)	3 (76)	3 (76)
Raw water pump flow - gpm (lpm)/rpm	122 (465)	136 (517)	143 (543)
Raw water pump max. suction head - in (m)	39 (1)	39 (1)	39 (1)
Max. raw water temp. at inlet -°F (°C)	86° (30°)	86° (30°)	86° (30°)

Cooling (Keel Cooled)			
Based on 70° F seawater and minimum full boat speed of 8 knots.			
Return water from keelcooler	70°-130° F.		
Water hose inside diameter - in (mm)	3 (76)	3 (76)	3 (76)
Head diameter - in	<b>All Models:</b> 2.5" NPT or 3" hose barb		
Turbo tube length - ft (m)	90 (28)	100 (30)	120 (36)
Skin cooler aluminum - sq ft (m <sup>2</sup> )	96 (9)	112 (11)	125 (12)
Skin cooler steel - sq ft (m <sup>2</sup> )	320 (30)	375 (36)	415 (40)

Electrical			
Voltage	<b>All Models:</b> 24V standard ground (isolated opt.)		
Min. battery capacity	<b>All Models:</b> 2 x 225 amp hours - 1150 CCA		
Battery cable size up to 10 ft run	"00"	"00"	"00"
Standard panel harness length - ft (m)	<b>All Models:</b> Std:20 ft (6m). Opt:10, 20, 40 ft		

Air and Exhaust			
Engine air consumption - cfm (m <sup>3</sup> /min)	1500 (43)	1729 (48.9)	1900 (53.8)
Min. engine room vent area - sq in (m <sup>2</sup> )	425 (0.27)	490 (0.32)	550 (0.54)
Exhaust gas flow at - cfm (m <sup>3</sup> /min)	4320 (123)	4628 (131)	5100 (144)
Exhaust gas temperature -°F (°C)	760 (404)	862 (461)	890 (476)
Max. exhaust back pressure - in (mm) H <sub>2</sub> O	30 (762)	30 (762)	30 (762)
Suggested dry exhaust I.D. - in (mm)	8 (203)	8 (203)	8 (203)
Suggested wet exhaust I.D. - in (mm)	10 (254)	12 (304)	12 (304)

Fuel and Oil			
Min. fuel suction and return line - in (mm)	5/8 (16)	5/8 (16)	5/8 (16)
Maximum fuel pump head - in (m)	39 (1)	39 (1)	39 (1)
Crankcase oil capacity - US gal (ltr)	26.4 (100)	26.4 (100)	26.4 (100)

Other Data			
Engine rotation (facing flywheel)	<b>All Models:</b> Counter-Clockwise		
Flywheel housing size	<b>All Models:</b> Std. SAE 0, 18"		
Optional front PTO size SAE # - inch	<b>All Models:</b> SAE 3-11" or SAE 4-10"		
Maximum operating angle any direction	<b>All Models:</b> 25° for less then 2 minutes		
Maximum installed operating angle	<b>All Models:</b> 12° rear down - 0° front down		

Approximate Weight*			
Keel Cooled Weight - without gear	5525 lbs (2505 kg)		
Heat Exchanger Weight - without gear	5725 lbs (2596 kg)		

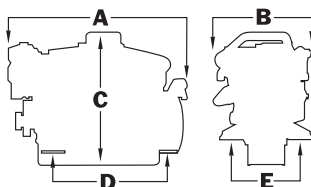

Dimensions	inch (mm)
A length	75.6 (1919)
B width	47 (1194)
C height	60.2 (1529)
D mounts	55.7 (1415)
E mounts	40 (1016)

\*Do NOT use for installation. Contact factory for current installation drawings.

## L6170A Performance Data

High Output Rating <sup>1</sup> FWHP / kW / @ rpm	900 / 666 / 2100
Medium Duty Rating <sup>1</sup> FWHP / kW / @ rpm	800 / 592 / 2000
Continuous Duty Rating FWHP / kW / @ rpm	700 / 518 / 1800

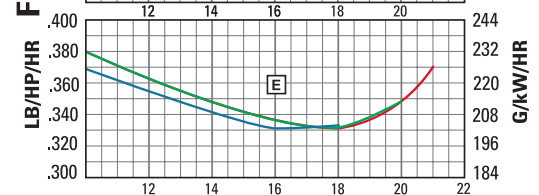
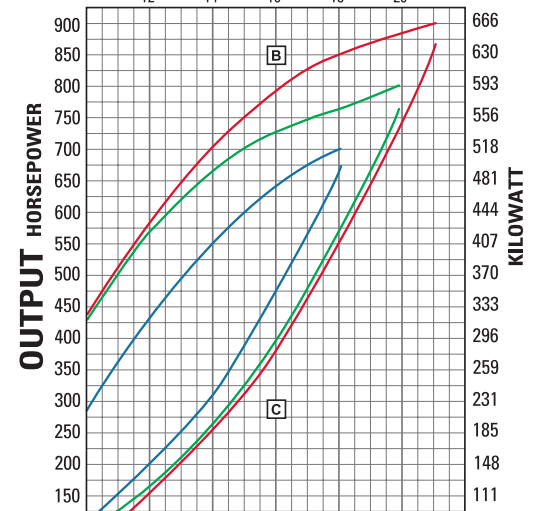
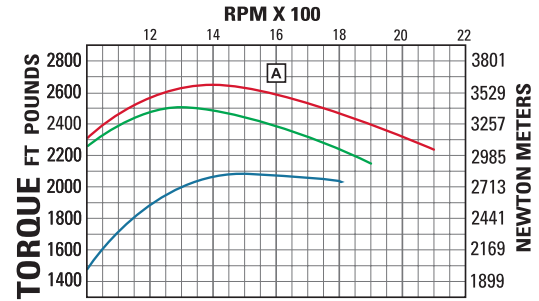

RATING	CONTINUOUS <sup>1</sup>				MEDIUM DUTY <sup>1</sup>				HIGH OUTPUT <sup>1</sup>			
	A	B	C	D	A	B	C	D	A	B	C	D
Curve												
RPM												
ft/lbs fwHP	1493	284	116	6.2	2258	430	96	5.4	2310	440	93	5.2
pdHP												
gph												
1000	1914	437	200	10.4	2494	570	167	8.8	2582	590	162	8.6
1200	2051	546	318	15.8	2475	660	265	13.4	2666	710	257	13.1
1400	2082	634	474	23	2380	725	395	19.4	2593	790	384	18.9
1600	2042	700	675	32.9	2246	770	563	27.6	2480	850	546	26.5
1800	--	--	--	--	2100	800	772	39.3	2310	880	750	38.1
2000	--	--	--	--	--	--	--	--	2250	900	868	47.2
2100	--	--	--	--	--	--	--	--	--	--	--	--

Note: 1. Ratings based on SAE J-1349. 2. Maximum cruise rpm: Continuous 1800. Medium 1800 and High 1900, or 200 below max attainable rpm whichever is lower.  
 Curves: A. Maximum torque at flywheel. B. Flywheel power. Prop shaft power is 3-3.5% lower due to marine reduction gear power loss. C. Theoretical prop power draw (3.0 exponent). D. Calculated fuel consumption based on theoretical propeller power draw. Your fuel consumption will vary higher or lower depending on your vessel and operating conditions. E. Specific fuel consumption.

Dealer

4420 14th Ave. NW., Seattle WA 98107  
 Tel: (206) 789-3880 • 1-800-762-0165 • Fax: (206) 782-5455  
 Information and dimensions subject to change without notice.  
 Northern Lights and Luggger are registered trademarks  
 of Alaska Diesel Electric, Inc.

© 2005 All rights reserved. Litho USA. L634 04/05

# LUGGER<sup>®</sup>

by NORTHERN LIGHTS

www.northern-lights.com