

Service Side

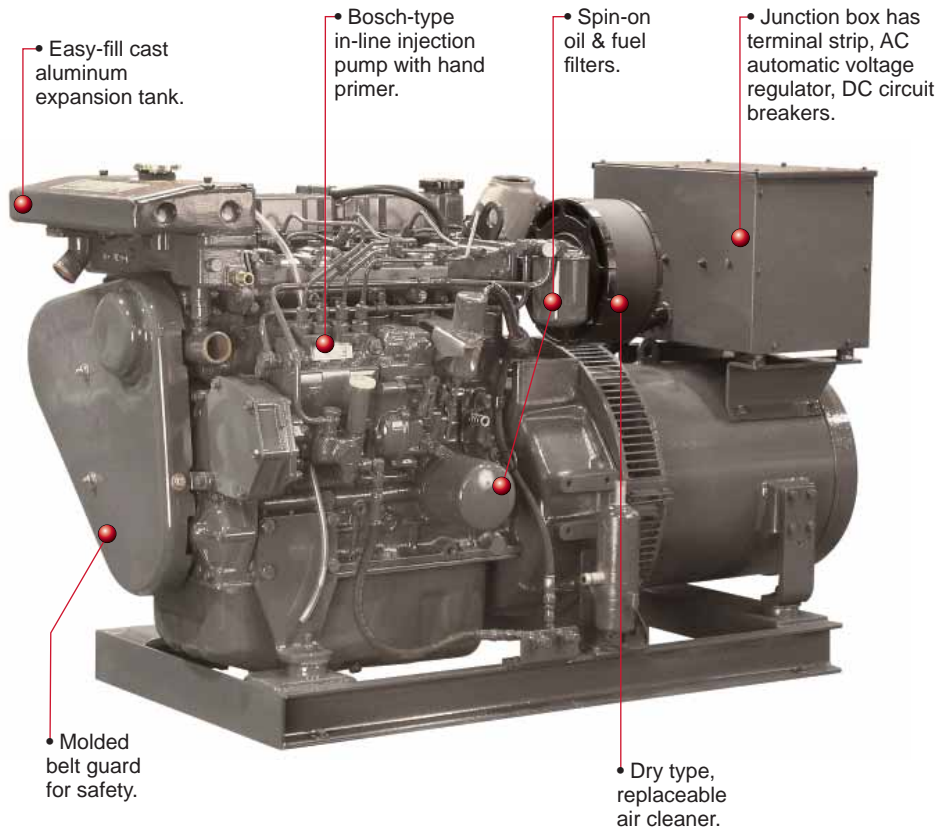

Non-Service Side

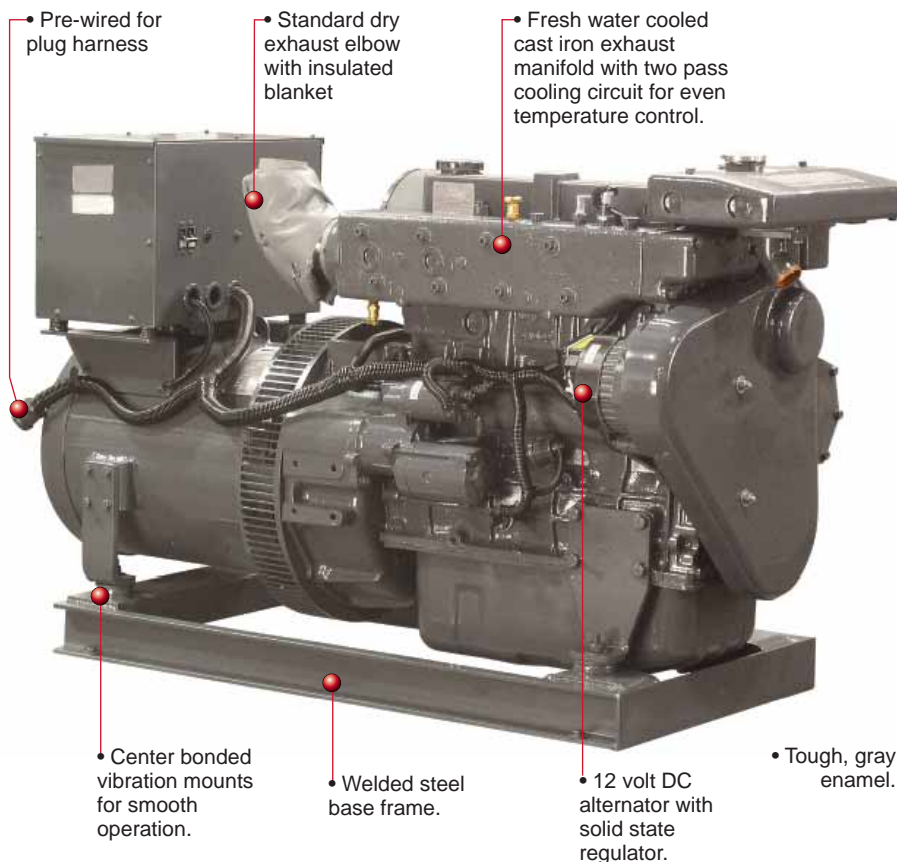

Commercial Series

30 kW

60 Hz / 1800 RPM

For 5 Decades, The Commercial Solution

Commercial operators have a specific and challenging set of expectations for their power systems. Generators should be able to run at full load for extended periods. If they can't; that equates to time lost and livelihoods threatened.

No one understands this better than Northern Lights. Our product line began in the unforgiving Alaskan fishing grounds. We have made improvements over the years, but have never forgotten the commitment to making the most reliable, durable and simple to use machines on the market.

Case in point: the M30CW. Cranking out 30 kW at 60 Hz, the M30CW is a true low-maintenance workhorse. Single side service, minimal hoses and belts, and an industry-best warranty all add up to an excellent "plug and play" power solution for the commercial operator whose bottom line depends on reliable performance.

The M30CW is engineered to withstand the rigors of commercial seagoing. Built for long life at full load, the M30CW is driven by a powerful Luger engine and features Northern Lights' exclusive W-Series generator end. The auxiliary stator winding provides real 300% short circuit protection and cleaner AC output than comparable generator models.

Easily customizable, the M30CW even has the ability to deliver full engine power to a front PTO, enabling the user to run winches, thrusters or deck gear at the touch of a button.

No detail has been overlooked in engineering a superior marine product. The 3.3 liter displacement provides plentiful power without the need for a turbocharger. The M30CW's freshwater cooled exhaust manifold is sturdy cast iron with two pass cooling for even temperature control with no dry runners.

For tugs, fishing boats or passenger vessels, the M30CW is a true turn-key workhorse. You can learn more about the M30CW marine generator set by contacting your local dealer or visiting our website.

M30CW3 Dimensional Drawing

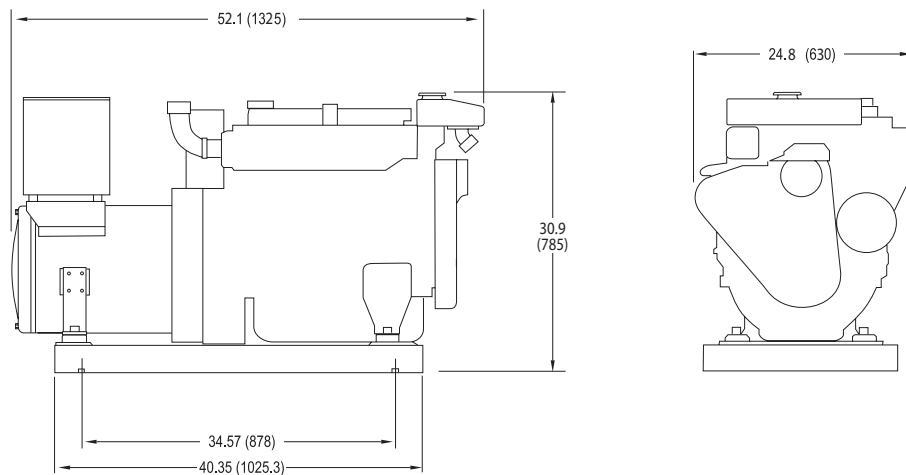

M30CW3 overall dimensions L x W x H: 52.1 x 24.8 x 30.9 inch (1325 x 630 x 785 mm)

Dimensions given in inches (mm). Dimensions subject to change without notice. Contact dealer or visit www.northern-lights.com for most current installation drawings.

AC Output¹

30 kW	60 Hz, 1800 RPM
Amperage	120-208 V/104 A
Phase/power factor	Std: 3/0.8 (Opt:1/1.0)
Voltage regulation	±1%

Lugger L944D Engine

Type	Vertical inline 4 cylinder diesel
Displacement	203 cubic in (3.33 ltr)
Bore/Stroke	3.7 / 4.7 in (94 / 120 mm)
HP @ RPM	49.0 @ 1800
Approx. fuel use	
1800 RPM @ full load ²	2.8 gph (9.8 lph)
1800 RPM @ half load ²	1.5 gph (5.3 lph)

Installation Data & Weight

Wet exhaust elbow	3 inch (76 mm) OD
Dry exhaust outlet	2 inch NPT
KC coolant inlet / outlet	1 1/2 inch OD
HE ³ raw water inlet	3/4 in (19 mm) OD
Fuel inlet hose / Fuel return	5/16 in / 1/4 in
Approximate dry weight	1,182 lbs (536 kg)

1. Based on SAE J1995 and ISO 3046.
2. Actual fuel consumption will vary depending on operating conditions.
3. Heat exchange cooling optional

Features and Benefits

W Series generator end

A Northern Lights exclusive, the W Series generator end features an auxiliary stator winding that supplies separate and stable power to the Automatic Voltage Regulator (AVR). This results in real 300% short circuit capability and improved AC circuit breaker performance.

Engine Block

- Four cycle, 4 cylinder, liquid cooled, naturally aspirated, overhead valve diesel based on an industrial engine block.
- Induction hardened crankshaft of forged carbon steel (stronger than cast iron)
- Helical cut and ground, carbon steel timing gears reduce noise.
- Cross flow head for efficient breathing.

Cooling System

- Freshwater cooling system in standard keel cooled configuration. (Heat exchanger optional)
- Large, easy fill expansion tank.
- Optional heat exchanger cooling includes: Tube-type heat exchanger has removable ends for easy cleaning. Easily accessible, rubber impeller seawater pump of bronze and stainless steel is gear driven; no drive belt

Intake and Exhaust

- Meets US EPA Tier III emission requirements.
- Dry type, replaceable air cleaner.
- Dry exhaust elbow with insulated cover - standard.
- Cast iron, wet exhaust elbow - optional.



Lubrication System

- Full flow, spin-on oil filter with bypass.
- 10.5 qt (10 ltr.) center well oil pan. 200 hour oil change intervals.
- Lube oil drain plug for quick oil changes.

Fuel System

- Indirect ignition with glow plugs.
- Bosch-type injection pump with 5% mechanical governor for close AC frequency control.
- Pintle type injectors.
- Mechanical lift pump with hand primer. No electric pump to fail.
- Large spin-on fuel filter.
- Stop solenoid controls the fuel rack, not throttle, for fast shutdowns and to eliminate speed variance and linkage problems.

DC Electrical System

- DC system uses reliable relays instead of unrepairable printed circuit board.
- 12 volt starter motor and battery charging alternator with regulator
- Standard panel: Remote mount S-3C has hour meter, oil pressure gauge, coolant temperature gauge, DC voltmeter, stop-start switch and preheat switch.
- 20 foot (6 m) plug-in panel harness lets you mount your panel anywhere onboard.
- Standard shutdowns for low oil pressure, high coolant temperature.



AC Generator

- Northern Lights, direct coupled, brushless AC generator is maintenance free. 4 lead-1 phase 50 or 60 Hz output optional. 12 lead-3 phase standard. Conservative heat rise rating: 95°C/50°C ambient.
- Quick ±1% RMS no load to full load voltage regulation. AVR has circuit breaker protection.
- Generator features high quality Class "H" epoxy insulation, accessible diodes, oversized bearings and junction box for wiring.

Special Equipment

- Welded steel base frame with drip pan.
- CBA mounts to isolate vibration.
- Tough gray enamel paint for long life finish.
- Operator's and parts manuals standard.
- Industry-best, transferrable warranty.

Optional Equipment

- Front power take off with 12 or 24V electric clutch and SAE B spline. Up to 49 HP available to vessel's hydraulic system at the touch of a button.
- Control panels with AC & DC gauges.
- 24 volt standard ground DC system
- Wire harness extensions and "Y" harness.
- Heat Exchange cooling.
- 3" Wet exhaust elbow.
- Onboard parts kits.
- Fuel filter-water separators.
- Shorepower switches.
- Alarms/shutdowns for low coolant level, low oil pressure.
- Owner's and parts manuals available on CD.



Dealer

4420 14th Ave. NW., Seattle WA 98107
 Tel: (206) 789-3880 • 1-800-762-0165 • Fax: (206) 782-5455
 Information and dimensions subject to change without notice.
 Northern Lights and Lugger are registered trademarks
 of Northern Lights, Inc.
 © 2007 All rights reserved. Litho USA. L699 05/09



www.northern-lights.com