

Service Side (Shown with Optional Sound Enclosure)

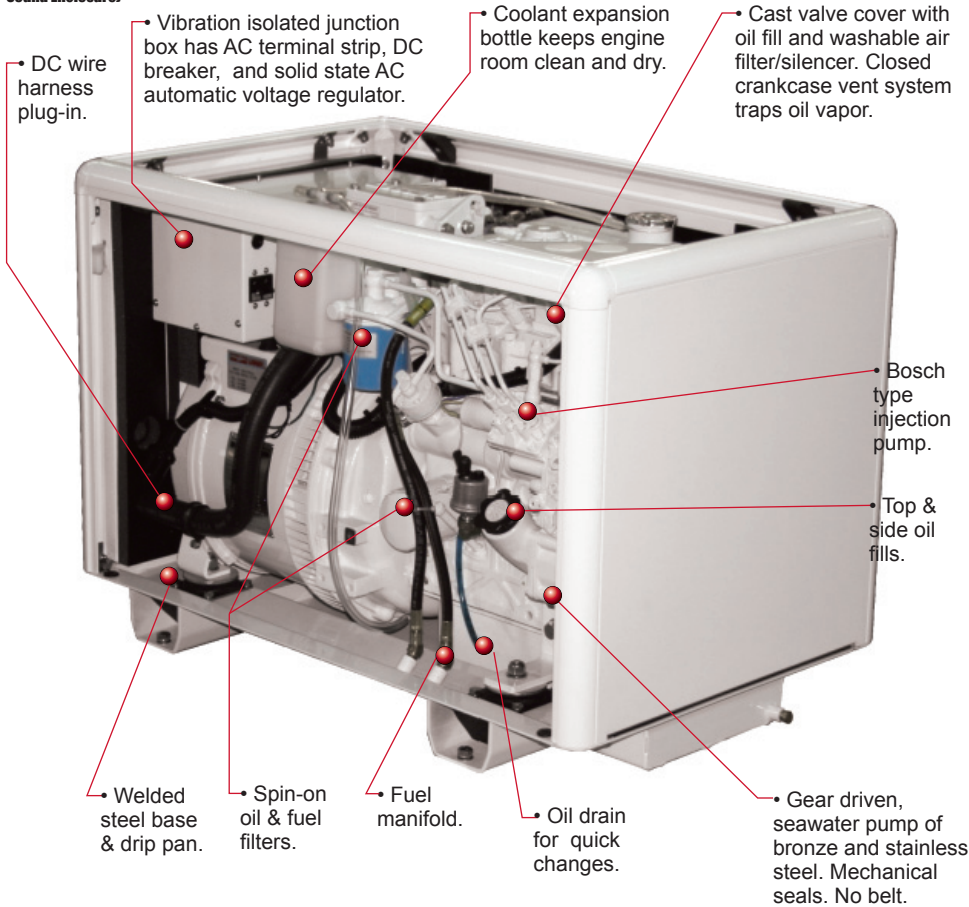

Non-Service Side

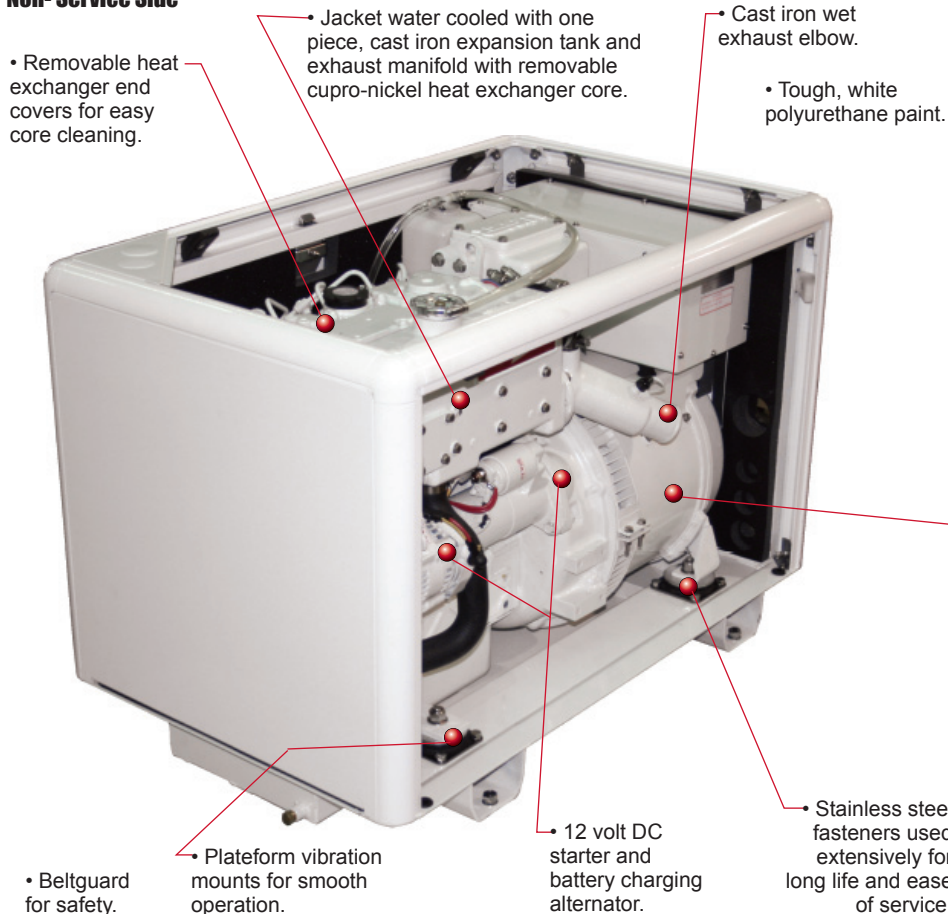

9 kW
60 Hz / 1800 RPM

7 kW
50 Hz / 1500 RPM

The M773LW3 incorporates the best Northern Lights features into one compact and versatile package. It meets growing onboard power demands without asking for a lot of engine room space.

The M773LW3 was engineered to deliver its power at a quiet, long lasting 1800 rpm. Driven by a high-torque, 69 cubic inch, Luger diesel and fitted with a powerful W-Series generator end, the M773LW3 has the power to start electric motors with ease.

Like all Northern Lights, simplicity and longevity are the focal points. Hoses and belts have been eliminated wherever possible. The closed crankcase vent system traps oil vapor emissions keeping the engine room, and environment, cleaner.

The M773LW3 features single-side service, which means it can be mounted with the non-service side facing a bulkhead without compromising routine service access.

Other proven systems are utilized throughout. The DC system has simple relays, instead of a printed circuit board, for quick, inexpensive field repairs. Low oil pressure, high coolant temperature and high exhaust temperature safety shutdowns are standard. An automatic voltage regulator keeps voltage to within $\pm 1\%$. Vibration isolating platform mounts, gleaming white polyurethane paint and a plug-in wire harness complete the package.

Northern Lights accessories can make this extraordinary genset into the perfect power source for your vessel. Choose from the long list of optional equipment that includes control panels, super attenuated sound enclosures and much more.

The M773LW3 meets the US EPA Tier III and IMO emission requirements.



Featuring the W-Series generator

The new W-Series generator end is a major step in our constant quest to give you the best generator set on the market. It features an auxiliary stator winding that supplies separate and stable power to the Automatic Voltage Regulator (AVR). The results are impressive:

- Classification society compliance.
 - Real 300% short circuit capability.
 - Improved AC circuit breaker performance.
- See your dealer for more information.



AC Output ¹	
9 kW	60 Hz, 1800 RPM, 1 Ph, 1.0 PF, 120-240 V/37.5A, 120 V/75A
7 kW	50 Hz, 1500 RPM, 1 Ph, 1.0 PF, 220 V/31.8A
Optional	Three Phase with 0.8 PF
Voltage regulation	±1%

Lugger L773LW Engine	
Type	Vertical inline 3 cylinder diesel
Displacement	69 in ³ (1.13 ltr)
Bore/Stroke	3.03/3.19 in (77/81 mm)
HP @ RPM	15/1800 12/1500

Approximate fuel use	
1800 RPM @ full load ²	0.93 gph (3.52 lph)
1800 RPM @ half load ²	0.51 gph (1.93 lph)
1500 RPM @ full load ²	0.72 gph (2.72 lph)
1500 RPM @ half load ²	0.37 gph (1.40 lph)

Installation Data & Weight	
Wet exhaust elbow	2 inch (51 mm) OD
Raw water inlet	3/4 inch (19 mm) OD
Fuel inlet and return	1/4 inch NPT
Approximate dry weight	540 lbs (245 kg)

1. Based on SAE J1995 and ISO 3046.
2. Actual fuel consumption will vary depending on operating conditions

M773LW3 Dimensional Drawing

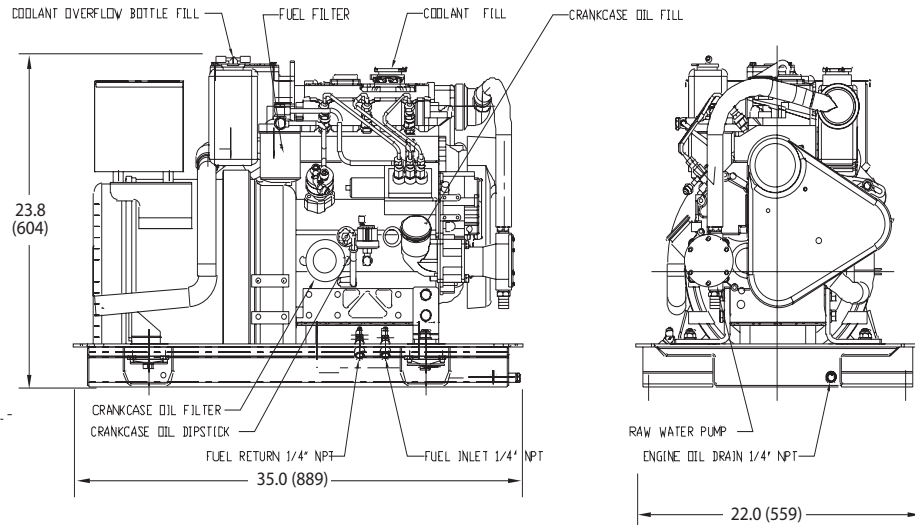

M773LW3 Overall Dimensions L x W x H: 35 x 22 x 23.8 inch (889 x 559 x 604 mm)
Sound Enclosure Dimensions L x W x H: 35 x 22 x 24.18 inch (889 x 558.8 x 614 mm)
Sound Enclosure Weight: 60 lbs. (27.2 kg)

Dimensions given in inches (mm). Dimensions subject to change without notice.
 Contact dealer or visit www.northern-lights.com for most current installation drawings.

M773LW Features and Benefits

Engine Block

- Four cycle, 3 cylinder, liquid cooled, naturally aspirated, overhead valve diesel.
- Swirl combustion chambers improve fuel efficiency and reduce smoke.
- Glow plugs for quick cold starting.

Cooling System

- Freshwater cooling system in heat exchanger or keel cooled configuration.
- One-piece heat exchanger, expansion tank and liquid cooled exhaust manifold. Fewer troublesome hoses and gaskets. Cast iron to resist corrosion and electrolysis.
- Heat exchanger cooling has tube-type, cupronickel heat exchanger with removable ends for easy cleaning. Gear driven, rubber impeller, seawater pump of bronze and stainless steel. No drive belt to worry about.

Fuel System

- Fuel system is self-venting.
- Injection pump with 5% mechanical governor for close AC frequency control.
- Pintle injectors with replaceable tips.
- Mechanical lift pump with hand primer. No electric pump to fail.
- Large spin-on fuel filter.
- Flexible fuel lines routed to fuel manifold.
- Stop solenoid controls the fuel rack, not throttle, to eliminate speed variance and linkage problems.

Intake and Exhaust

- Meets US EPA Tier III emission requirements at date of manufacture.
- Washable air cleaner in cast intake manifold reduces noise. Closed crankcase vent.
- Cast iron, wet exhaust elbow for safety.



Lubrication System

- Full flow, spin-on oil filter with bypass.
- 4.2 qt. (4 ltr) oil capacity for better lubrication. 200 hr. oil change intervals.
- Oil drain for quick, clean oil changes.

DC Electrical System

- DC system uses reliable relays instead of unrepairable printed circuit board.
- 12 volt starter motor and battery charging alternator with regulator and belt guard.
- Standard panel: Remote mount S-1B has hour meter, stop-start switch with run light and preheat switch.
- Expandable to six panels installed up to 110 feet from the set.
- 20 foot (6 m) plug-in panel harness lets you mount your panel anywhere onboard. Better than an inaccessible unit mount panel that is prone to vibration problems.
- Low oil pressure, high coolant temperature and high exhaust temperature safety shutdowns standard.



AC Generator

- Northern Lights, direct coupled, brushless AC generator is maintenance free. 4 lead, 1 phase, 50 or 60 Hz output standard. 12 lead-3 phase optional. Conservative heat rise rating: 95°C/50°C ambient.
- Automatic Voltage Regulator is powered by dedicated AC winding for true 300% short circuit capability. Quick ±1% RMS no load to full load voltage regulation. AVR has circuit breaker protection.
- Generator features high quality, Class "H" epoxy insulation, accessible diodes, over-sized bearings and junction box for wiring.

Special Equipment

- Welded steel base frame with drip pan.
- Four platform mounts isolate vibration.
- White, long-life polyurethane paint.
- Operator's and parts manuals standard.

Classification Standards

- Contact factory for details.



New enclosure package is 28% smaller than previous design

Northern Lights' revolutionary new sound enclosure shares a base frame with the generator set, creating a compact power and sound attenuation package and boasts 28% less overall cubic volume than the previous enclosed units.



- Vibration isolation mounts for smooth, quiet performance
- Stainless steel paddle latch on service side.
- Interior panel retention system allows generator access at nonservice panels without using tools.
- Electrogalvanized steel composition allows for single layer of foam insulation, with superior noise attenuation.
- Protective film coating ensures safety and longevity.
- External fuel connections for easy installation.
- Front exhaust exit option.
- Tough, white, powder-coat finish.

Dealer

4420 14th Ave. NW., Seattle WA 98107
 Tel: (206) 789-3880 • 1-800-762-0165 • Fax: (206) 782-5455
 Information and dimensions subject to change without notice.
 Northern Lights and Lugger are registered trademarks of Northern Lights, Inc.

