

CONTROL PANEL
(S-38)

RELAY BOARD
(LOCATED IN GENERATOR J-BOX)

ENGINE

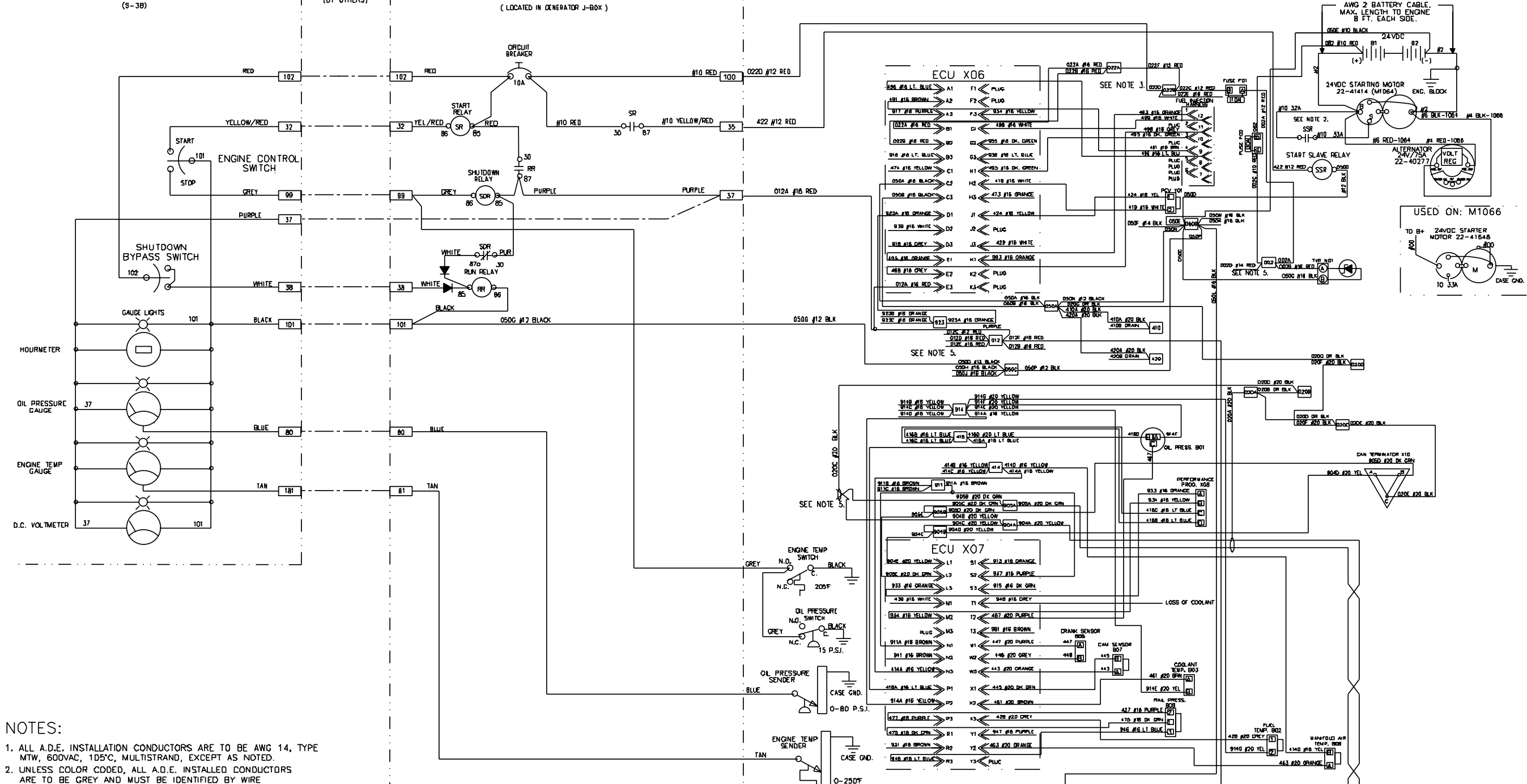

- NOTES:
1. ALL A.D.E. INSTALLATION CONDUCTORS ARE TO BE AWG 14, TYPE MTW, 600VAC, 1D5'C, MULTISTRAND, EXCEPT AS NOTED.
 2. UNLESS COLOR CODED, ALL A.D.E. INSTALLED CONDUCTORS ARE TO BE GREY AND MUST BE IDENTIFIED BY WIRE MARKER AT EACH CONNECTION POINT.
 3. REMOVE AND DISCARD REMOTE ON/OFF AND FUEL HEATER CONNECTORS, WIRE AS SHOWN.
 4. ALL ENGINE MANUFACTURER WIRE HARNESS CONDUCTORS CONNECTED TO A.D.E. PROVIDED CIRCUITRY ARE TO BE IDENTIFIED BY WIRE MARKER AT INTERCONNECTION POINT W/MFR.'S WIRE CODE NO.
 5. ALL UNTERMINATED MANUFACTURER WIRE HARNESS CONDUCTORS ARE TO BE ISOLATED, USING APROPRIATELY SIZED HEAT SHRINK TUBING. PINCH END WITH PLIERS WHILE HOT TO SEAL TERMINATION.

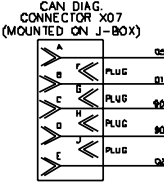

D.C. Wiring - 24 Volt Standard Ground for M1064H & M1066H
Drawing D-3828

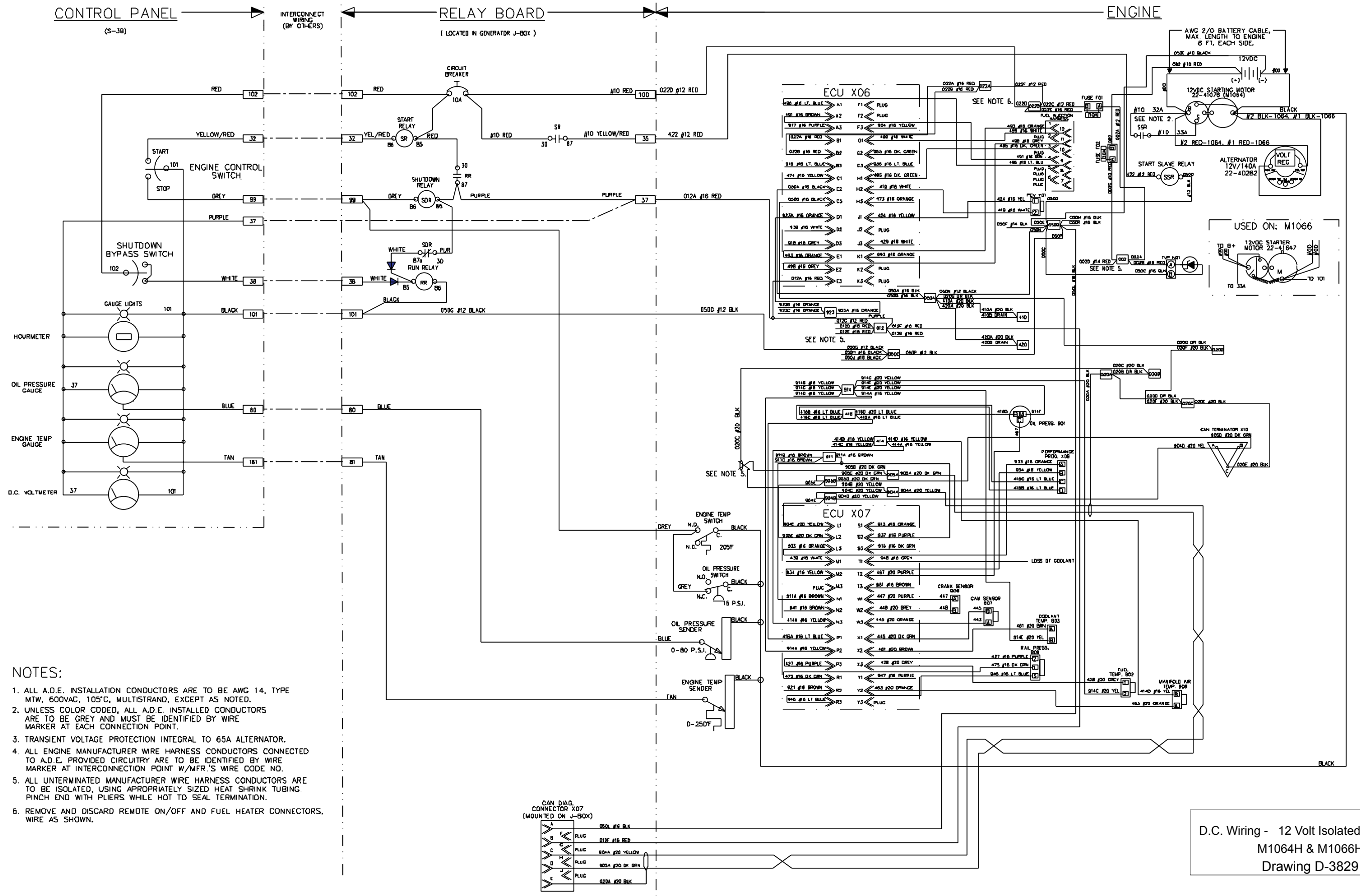

- NOTES:**
1. ALL A.D.E. INSTALLATION CONDUCTORS ARE TO BE AWG 14, TYPE MTW, 600VAC, 105°C, MULTISTRAND, EXCEPT AS NOTED.
 2. UNLESS COLOR CODED, ALL A.D.E. INSTALLED CONDUCTORS ARE TO BE GREY AND MUST BE IDENTIFIED BY WIRE MARKER AT EACH CONNECTION POINT.
 3. TRANSIENT VOLTAGE PROTECTION INTEGRAL TO 65A ALTERNATOR.
 4. ALL ENGINE MANUFACTURER WIRE HARNESS CONDUCTORS CONNECTED TO A.D.E. PROVIDED CIRCUITRY ARE TO BE IDENTIFIED BY WIRE MARKER AT INTERCONNECTION POINT W/MFR.'S WIRE CODE NO.
 5. ALL UNTERMINATED MANUFACTURER WIRE HARNESS CONDUCTORS ARE TO BE ISOLATED, USING APPROPRIATELY SIZED HEAT SHRINK TUBING. PINCH END WITH PLIERS WHILE HOT TO SEAL TERMINATION.
 6. REMOVE AND DISCARD REMOTE ON/OFF AND FUEL HEATER CONNECTORS, WIRE AS SHOWN.

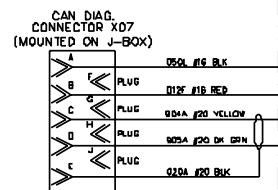

D.C. Wiring - 12 Volt Isolated Ground for M1064H & M1066H Drawing D-3829

CONTROL PANEL

(S-38)

INTERCONNECT WIRING (BY OTHERS)

RELAY BOARD

(LOCATED IN GENERATOR J-BOX)

ENGINE

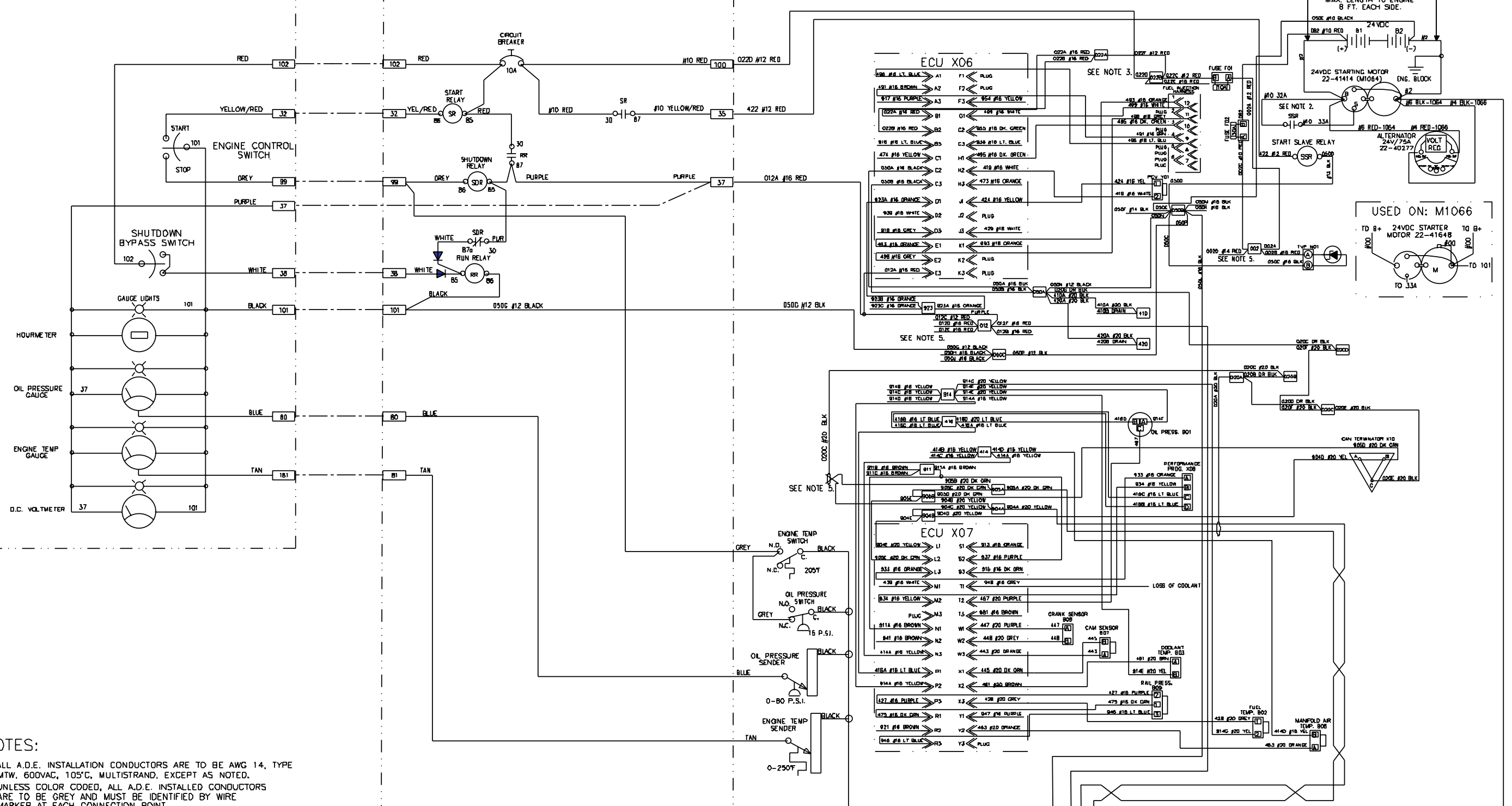

NOTES:

1. ALL A.D.E. INSTALLATION CONDUCTORS ARE TO BE AWG 14, TYPE MTW, 600VAC, 105°C, MULTISTRAND, EXCEPT AS NOTED.
2. UNLESS COLOR CODED, ALL A.D.E. INSTALLED CONDUCTORS ARE TO BE GREY AND MUST BE IDENTIFIED BY WIRE MARKER AT EACH CONNECTION POINT.
3. REMOVE AND DISCARD REMOTE ON/OFF AND FUEL HEATER CONNECTORS, WIRE AS SHOWN.
4. ALL ENGINE MANUFACTURER WIRE HARNESS CONDUCTORS CONNECTED TO A.D.E. PROVIDED CIRCUITRY ARE TO BE IDENTIFIED BY WIRE MARKER AT INTERCONNECTION POINT W/MFR.'S WIRE CODE NO.
5. ALL UNTERMINATED MANUFACTURER WIRE HARNESS CONDUCTORS ARE TO BE ISOLATED, USING APPROPRIATELY SIZED HEAT SHRINK TUBING. PINCH END WITH PLIERS WHILE HOT TO SEAL TERMINATION.

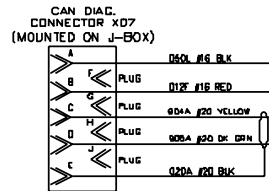

D.C. Wiring - 24 Volt Isolated Ground for M1064H & M1066H Drawing D-3830