

THE DIMENSIONS ON THIS DRAWING ARE SUBJECT TO CHANGE. PLEASE CONTACT NORTHERN LIGHTS INC TO BE SURE YOU HAVE THE MOST CURRENT REVISION.

WEIGHT: 676 KG [1490 LBS]

P/N	APPLICATION
05-01200	NLI WHITE T009-WH12
05-01205	TRAFFIC WHITE RAL 9016

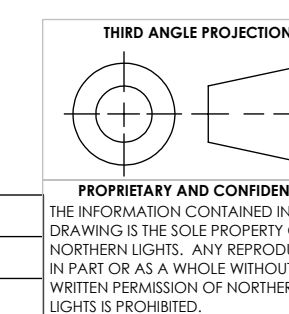

PROPRIETARY AND CONFIDENTIAL
THE INFORMATION CONTAINED IN THIS DRAWING IS THE SOLE PROPERTY OF NORTHERN LIGHTS. ANY REPRODUCTION IN PART OR AS A WHOLE WITHOUT THE WRITTEN PERMISSION OF NORTHERN LIGHTS IS PROHIBITED.

REV.	DESCRIPTION	DATE	BY	CHECKED
C	ADDED TSC PANEL OPTION, MOVED OPTIONS TO SHEET 2 OF 2, RESTORE SHEET 1 TO BASE CONFIGURATION. ECN# 4347	10/5/2016	LTP	TAH 10/7/2016
B	DELETE WAVENET, UPDATE LOGO AND ADDED WEIGHT DATA PER ECN#3381	10/23/2015	LTP	TAH 10/29/2015
A	UPDATED INSTALLATION DWG TO SHOW DRY EXHAUST OPTION. ECN#1836	08/01/2011	LTP	MG 08/01/2011

UNLESS OTHERWISE SPECIFIED:	NAME	DATE
DRAWN	LTP	6/28/2011
CHECKED		
ENG APPR.		
MEG APPR.		
Q.A.		
INTERPRET GEOMETRIC TOLERANCING PER: ASME Y14.5M		
MATERIAL:		
FINISH:		
DO NOT SCALE		

4420 14th AVE. N.W. Seattle, WA 98107 (206) 789-3880 www.northern-lights.com	
NORTHERN LIGHTS	
TITLE: INSTALLATION DIMENSIONS M944W3 SOUND SHIELD	
SIZE: D	PART NO. SEE TABLE
SCALE: 1:10	DWG. NO. D-4526
WEIGHT:	REV D
	SHEET 1 OF 2

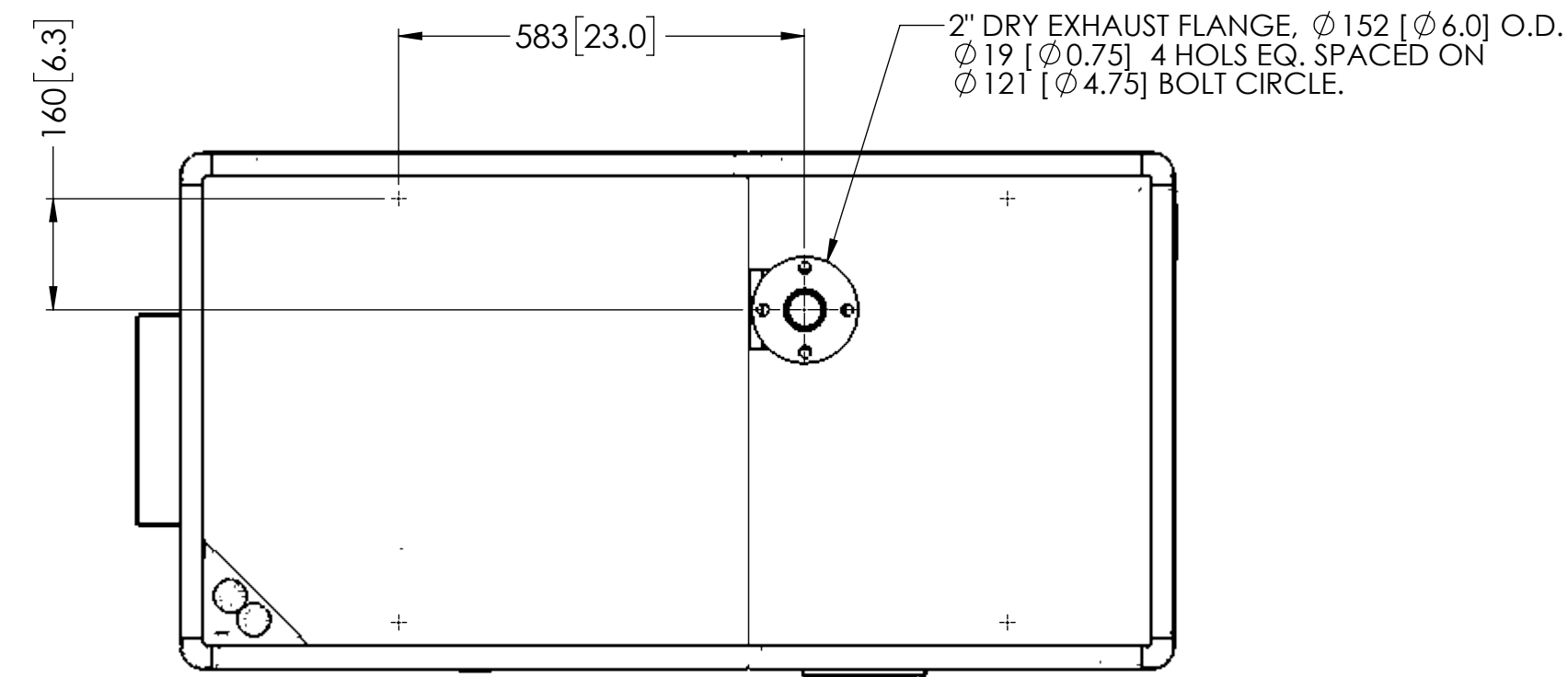

PLAN VIEW

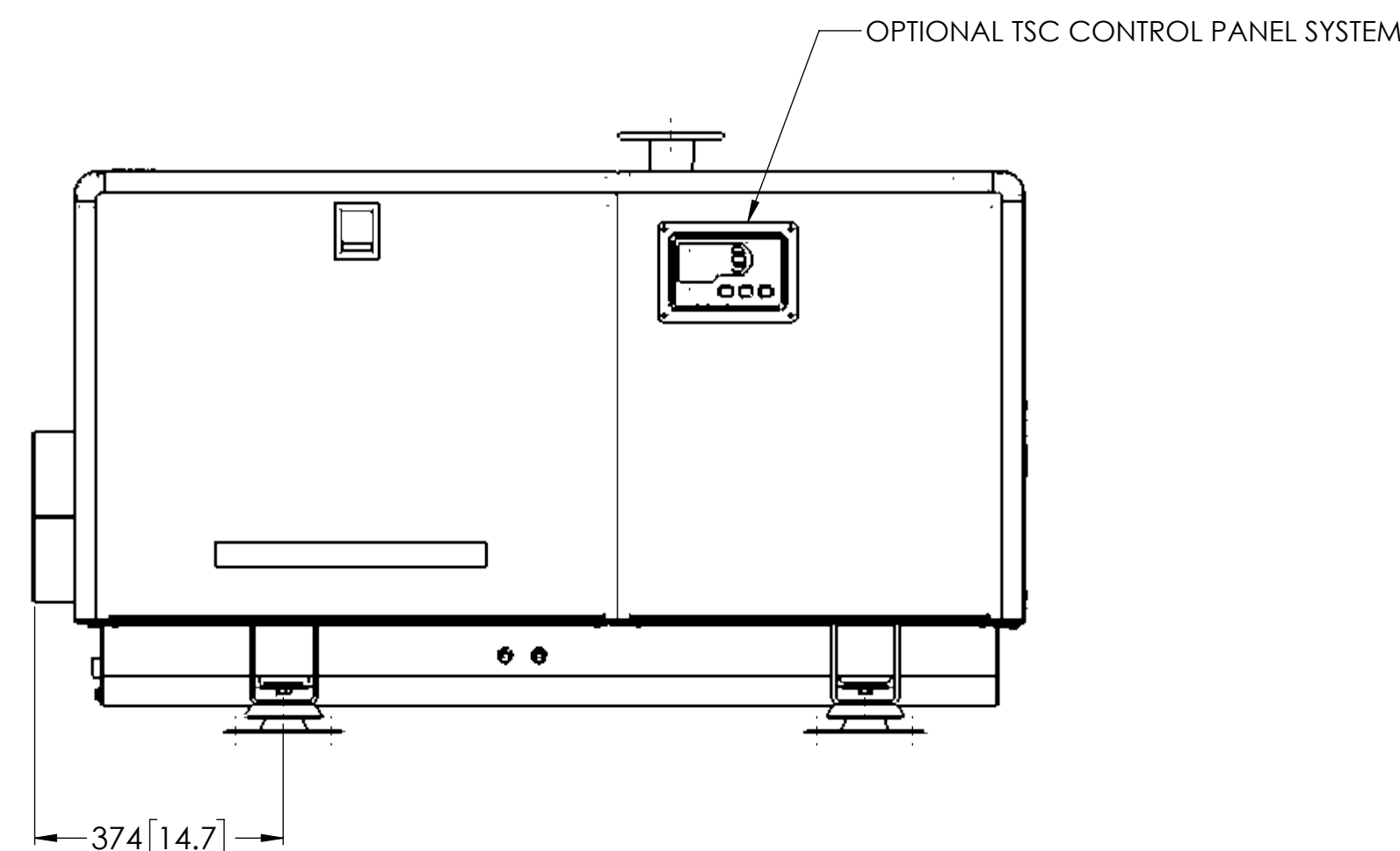
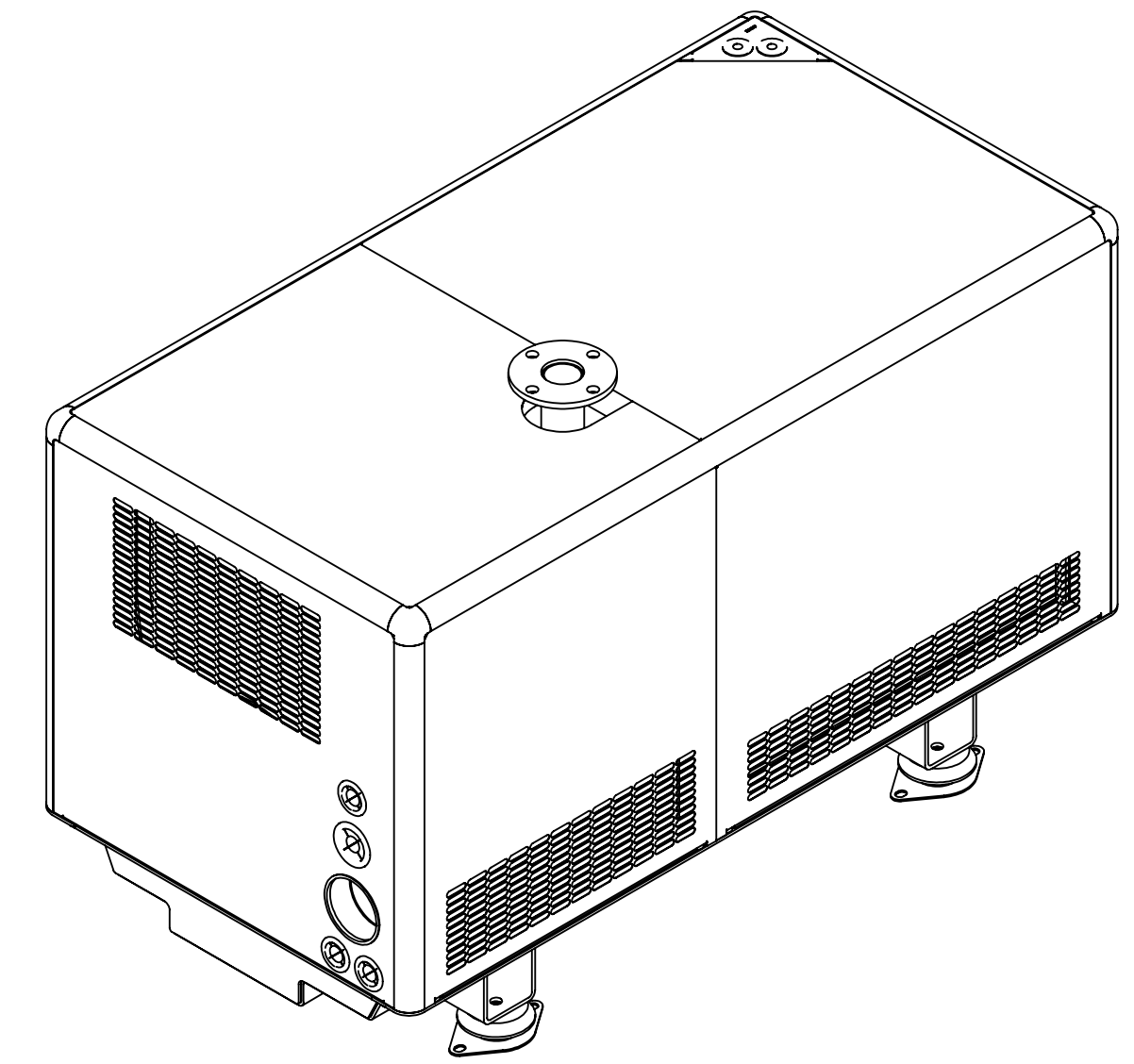
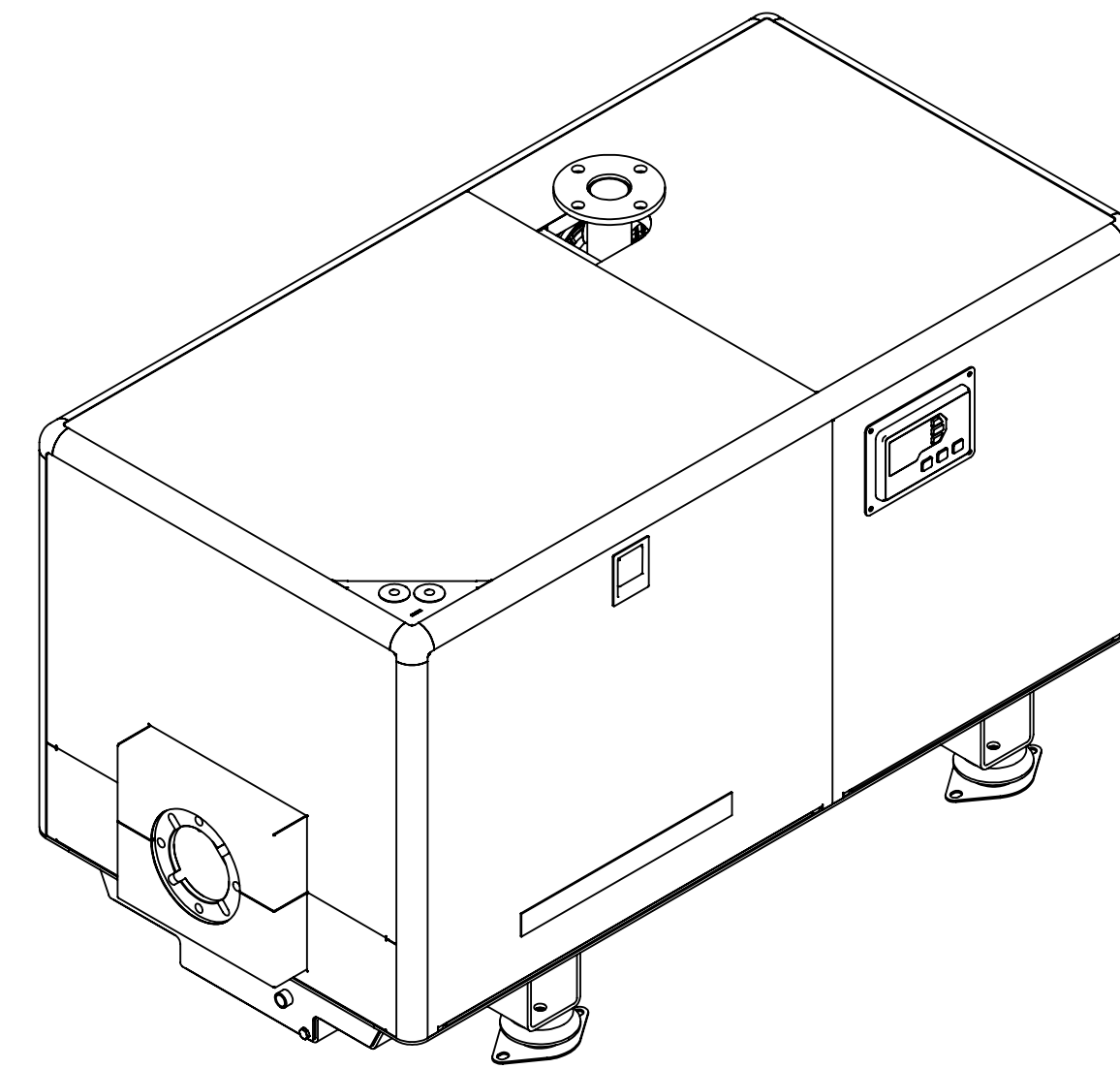

LEFT (SERVICE) SIDE VIEW

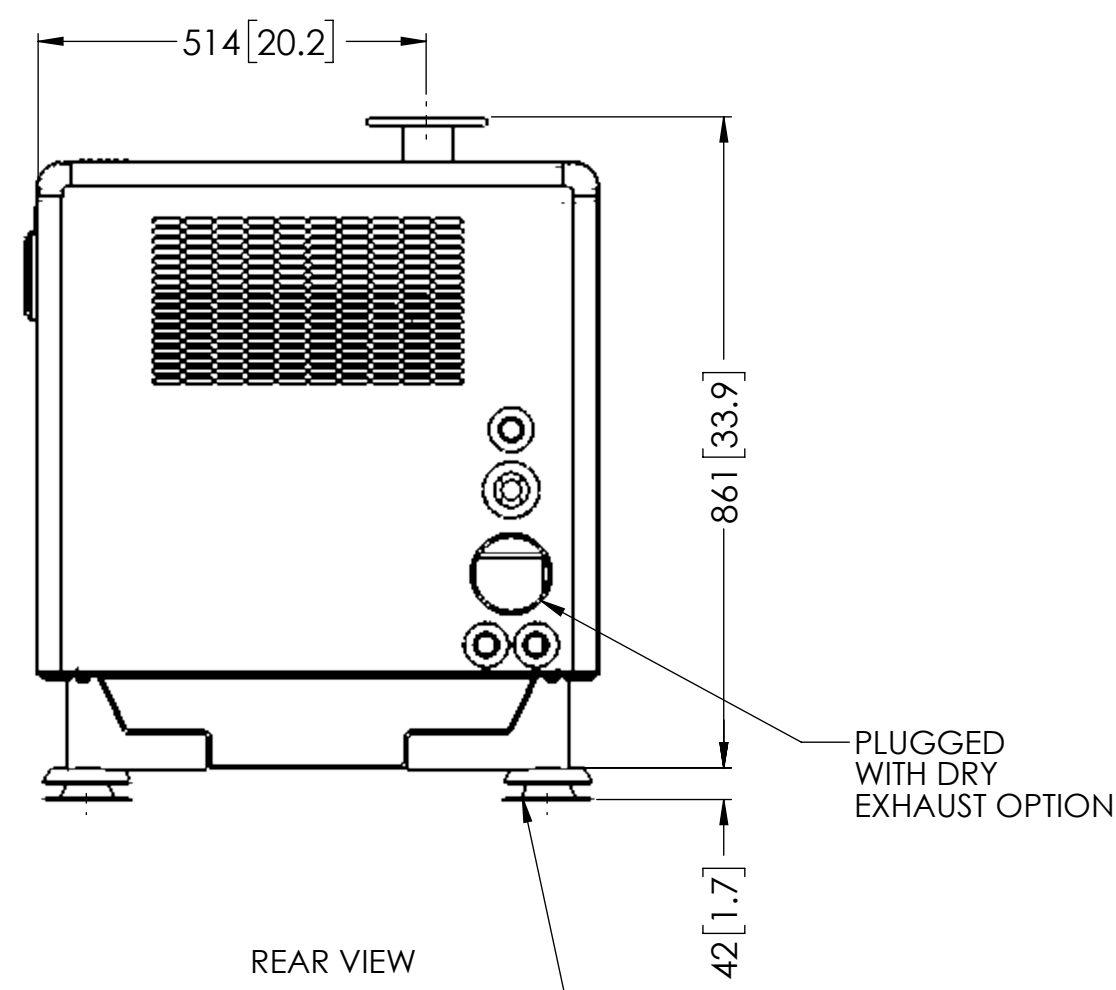

REAR VIEW

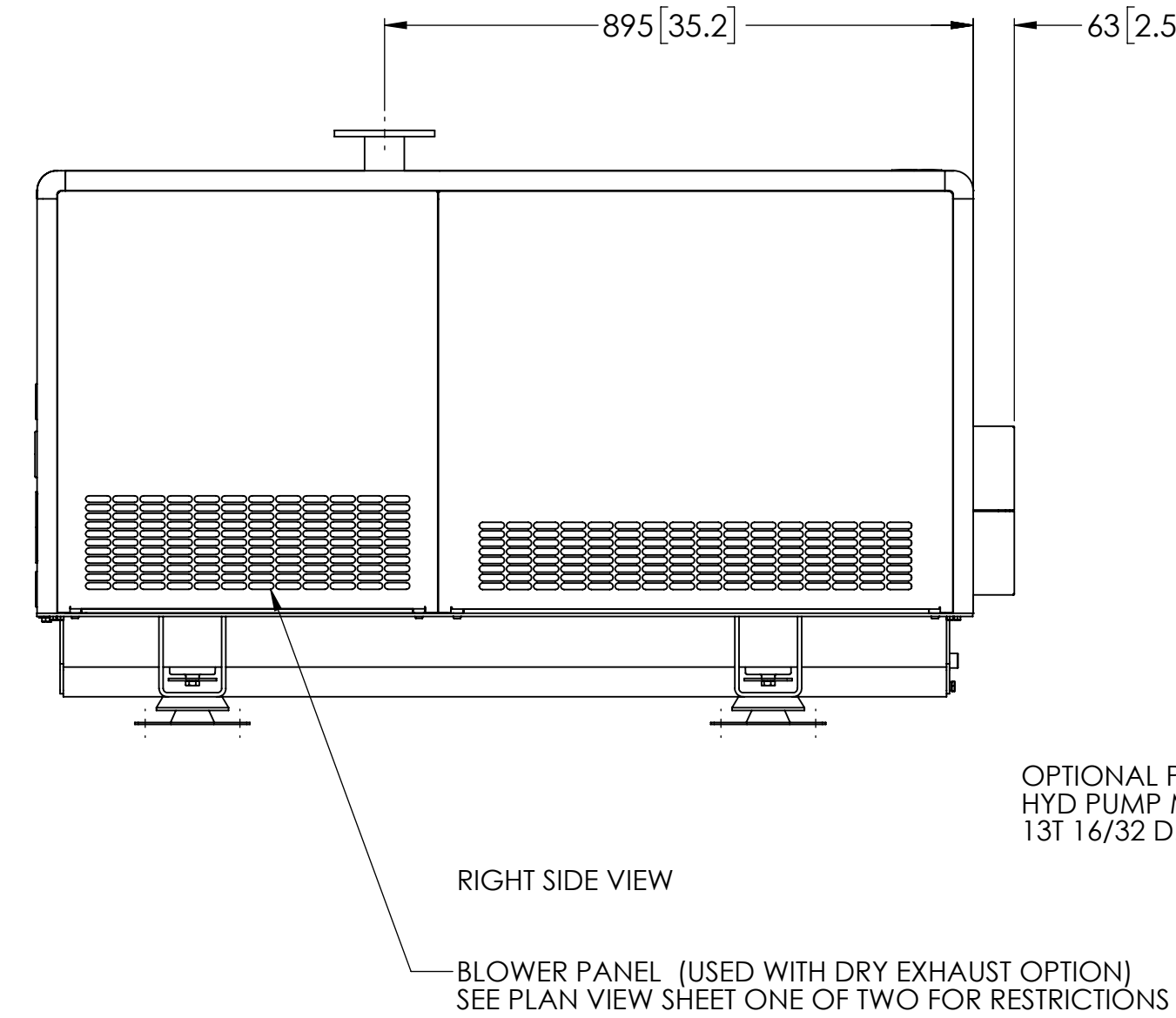

RIGHT SIDE VIEW

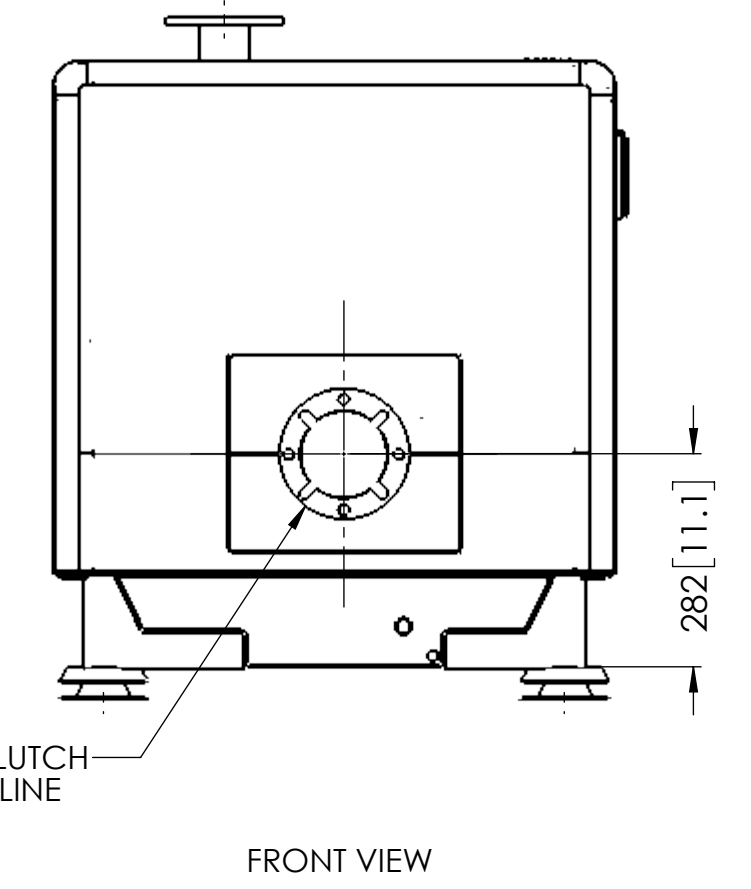

FRONT VIEW

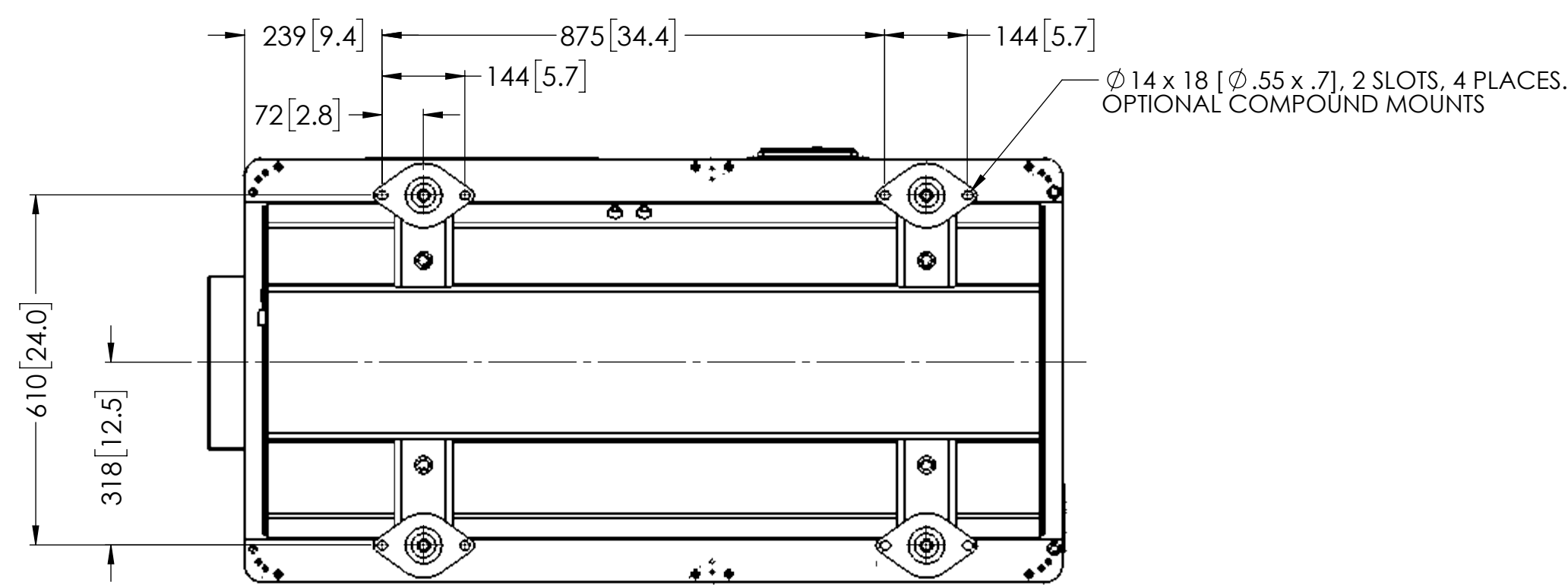

BOTTOM VIEW

THE DIMENSIONS ON THIS DRAWING ARE SUBJECT TO CHANGE. PLEASE CONTACT NORTHERN LIGHTS INC., TO BE SURE YOU HAVE THE MOST CURRENT REVISION.

WEIGHTS: 676 KG [1490 LBS]
 ADD 31.8 KG [70 LBS] FOR PTO OPTION.

P/N	APPLICATION
05-01200	NLI WHITE T009-WH12
05-01205	TRAFFIC WHITE RAL 9016

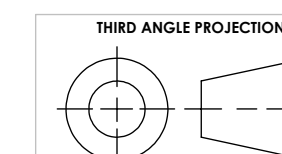

PROPRIETARY AND CONFIDENTIAL
 THE INFORMATION CONTAINED IN THIS DRAWING IS THE SOLE PROPERTY OF NORTHERN LIGHTS. ANY REPRODUCTION IN PART OR AS A WHOLE WITHOUT THE WRITTEN PERMISSION OF NORTHERN LIGHTS IS PROHIBITED.

REV.	DESCRIPTION	DATE	BY	CHECKED
C	ADDED TSC PANEL OPTION, MOVED OPTIONS TO SHEET 2 OF 2, RESTORE SHEET 1 TO BASE CONFIGURATION, ECN#4347	10/5/2016	LTP	TAH 10/7/2016
B	DELETE WAVENET, UPDATE LOGO AND ADDED WEIGHT DATA PER ECN#3581	10/23/2015	LTP	TAH 10/29/2015
A	UPDATED INSTALLATION DWG TO SHOW DRY EXHAUST OPTION, ECN#1836	08/01/2011	LTP	MG 08/01/2011

REV.	DESCRIPTION	DATE	BY	CHECKED
C	ADDED TSC PANEL OPTION, MOVED OPTIONS TO SHEET 2 OF 2, RESTORE SHEET 1 TO BASE CONFIGURATION, ECN#4347	10/5/2016	LTP	TAH 10/7/2016
B	DELETE WAVENET, UPDATE LOGO AND ADDED WEIGHT DATA PER ECN#3581	10/23/2015	LTP	TAH 10/29/2015
A	UPDATED INSTALLATION DWG TO SHOW DRY EXHAUST OPTION, ECN#1836	08/01/2011	LTP	MG 08/01/2011

UNLESS OTHERWISE SPECIFIED:	NAME	DATE
DIMENSIONS ARE IN MILLIMETERS	LTP	6/28/2011
TOLERANCES:		
ANGULAR:		
MAX CHG 0.5°		
BEND ± 1.0°		
X ± 1.0		
INTERPRET GEOMETRIC TOLERANCING PER ASME Y14.5M		
MATERIAL:		
FINISH:		
DO NOT SCALE		

		4420 14th AVE. N.W. Seattle, WA 98107 (206) 789-3880 www.northern-lights.com	
TITLE: INSTALLATION DIMENSIONS M944W3 SOUND SHIELD, OPTIONAL EQUIPMENT			
SIZE	PART NO.	DWG. NO.	REV
D	SEE TABLE	D-4526	C
SCALE: 1:10	WEIGHT:	SHEET 2 OF 2	