

PLAN VIEW

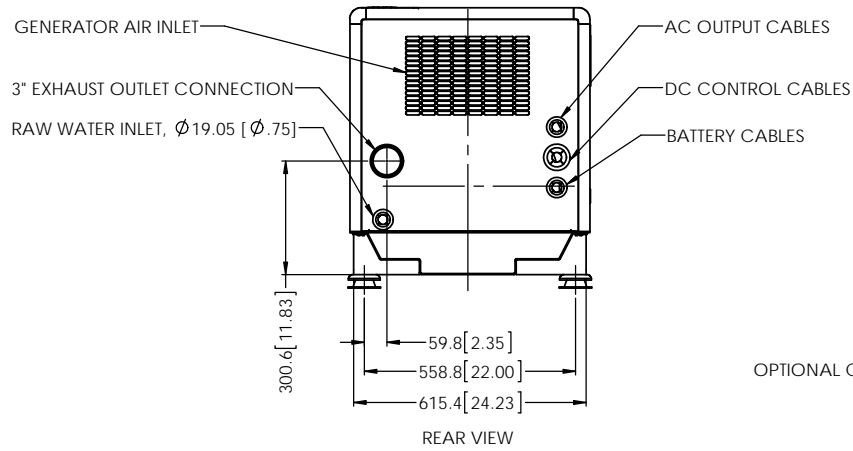

REAR VIEW

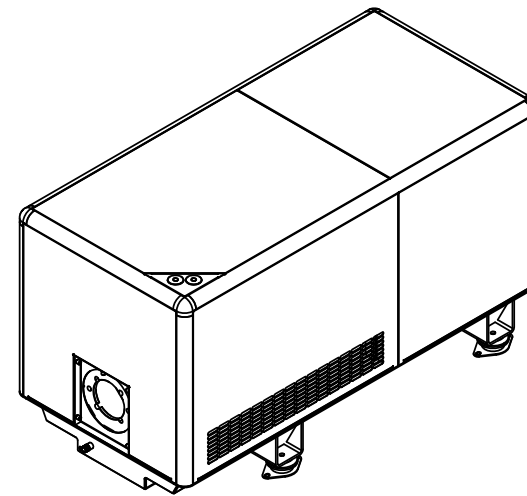
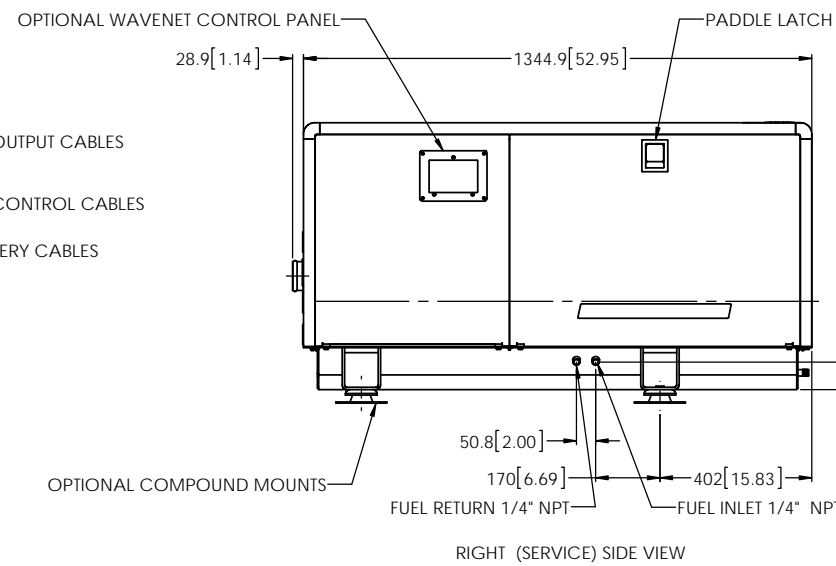

RIGHT (SERVICE) SIDE VIEW

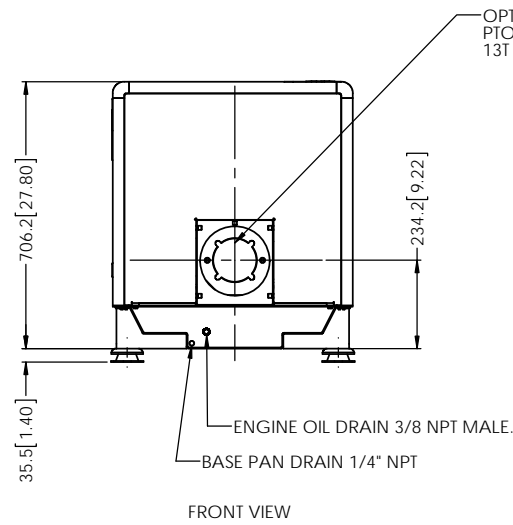

FRONT VIEW

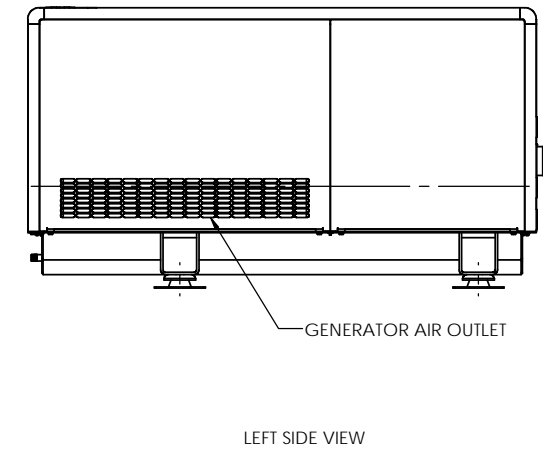

LEFT SIDE VIEW

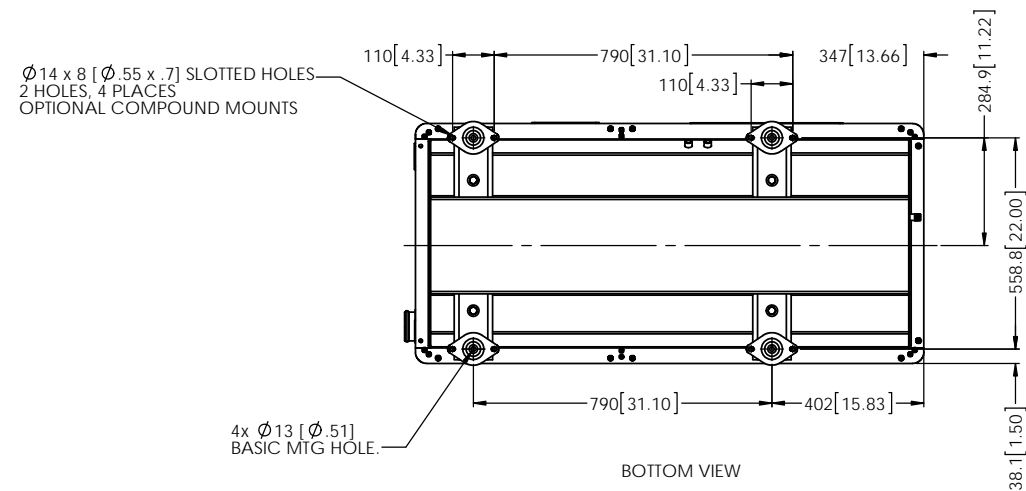

BOTTOM VIEW

TOTAL WEIGHT (WET): 514 KG. [1133 LBS.]  
ADD 29.5 KG [65 lbs] FOR PTO OPTION.

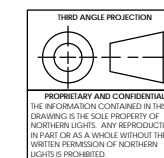

PROPRIETARY AND CONFIDENTIAL  
THE INFORMATION CONTAINED IN THIS DRAWING IS THE SOLE PROPERTY OF NORTHERN LIGHTS. ANY REPRODUCTION IN PART OR AS A WHOLE WITHOUT THE WRITTEN PERMISSION OF NORTHERN LIGHTS IS PROHIBITED.

UNLESS OTHERWISE SPECIFIED:		NAME	DATE	 <small>4420 14th AVE. N.W. Seattle, WA 98107 (206) 789-3880 www.northern-lights.com</small>
DIMENSIONS ARE IN MILLIMETERS		LTP	1/10/12	
TOLERANCES:		DRAWN		TITLE:
ANGULAR- MACH 0.15° BEND ± 10°		CHECKED		INSTALLATION DIMENSIONS M864W3 SOUND SHIELD
X ± 0.5		ENG APPR		
X.X ± 0.3		MFG APPR		SIZE DWG. NO.
INTERPRET GEOMETRIC TOLERANCING PER ASME Y14.5M		C/A		D-4565
MATERIAL:		COMMENTS:		REV
NEXT ASSY	USED ON	FRSH		SCALE: 1:10
APPLICATION				WEIGHT: SHEET 1 OF 1

D-4565