

MODEL	WET WEIGHT lbs [kg]**	CG 'A'	CG 'B'	CG 'C'	*CG VALUES SHOWN ARE FROM CRANKSHAFT CENTERLINE
M1064T1 55 kW 1800 RPM 3 Ø	2504 [1136]	5.23 [133]	1.3 [33]	0.8 [20]	** SEE NOTE 4.
M1064T1 50 kW 1500 RPM 3 Ø	2504 [1136]	5.23 [133]	1.3 [33]	0.8 [20]	
M1064T1 55 kW 1800 RPM 1 Ø	2594 [1177]	4.45 [113]	1.8 [46]	0.8 [20]	
M1064T1 50 kW 1500 RPM 1 Ø	2594 [1177]	4.45 [113]	1.8 [46]	0.8 [20]	
M1064T2 65 kW 1800 RPM 3 Ø	2594 [1177]	4.45 [113]	1.8 [46]	0.8 [20]	
M1064T2 55 kW 1500 RPM 3 Ø	2594 [1177]	4.45 [113]	1.8 [46]	0.8 [20]	

*CG VALUES SHOWN ARE FROM CRANKSHAFT CENTERLINE
 ** SEE NOTE 4.

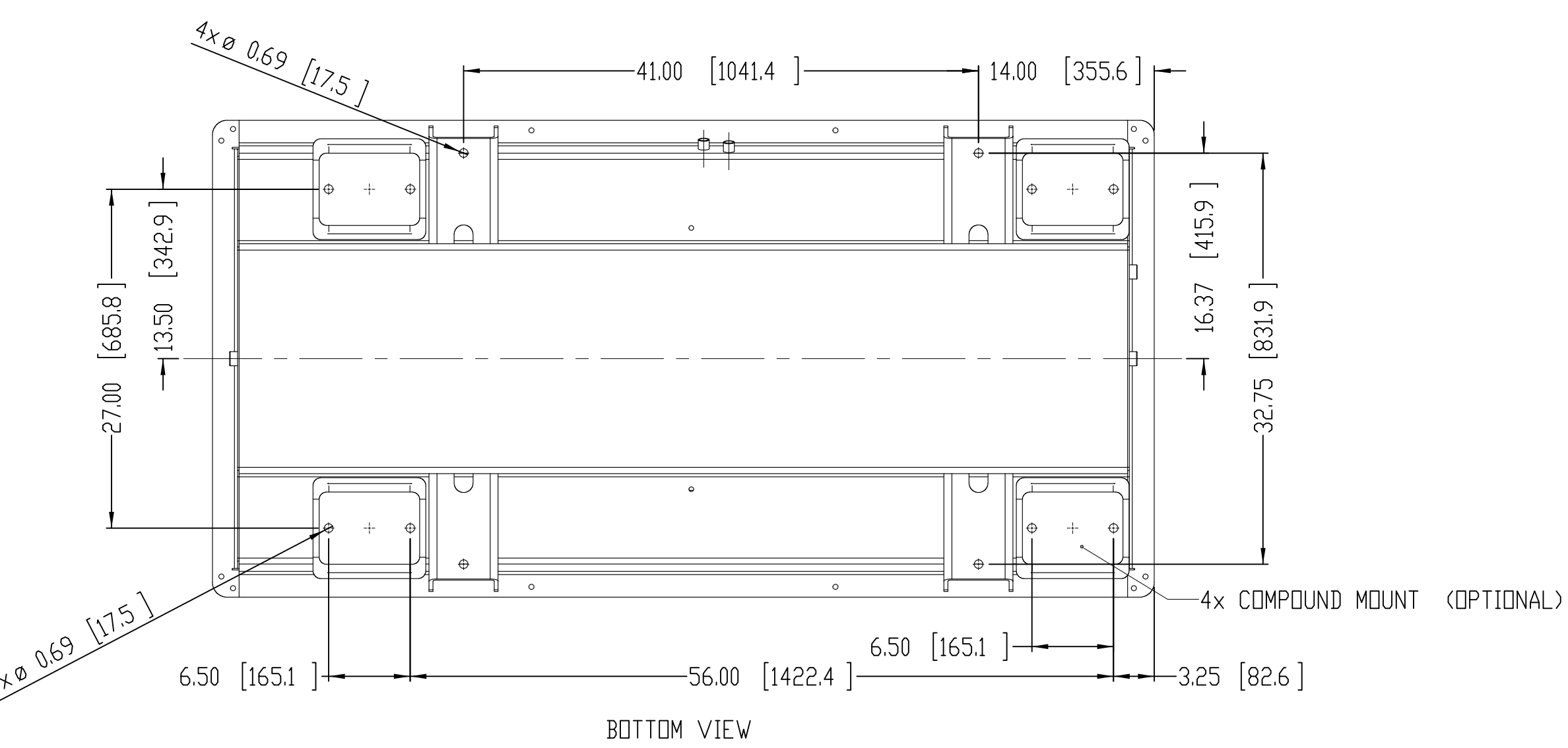
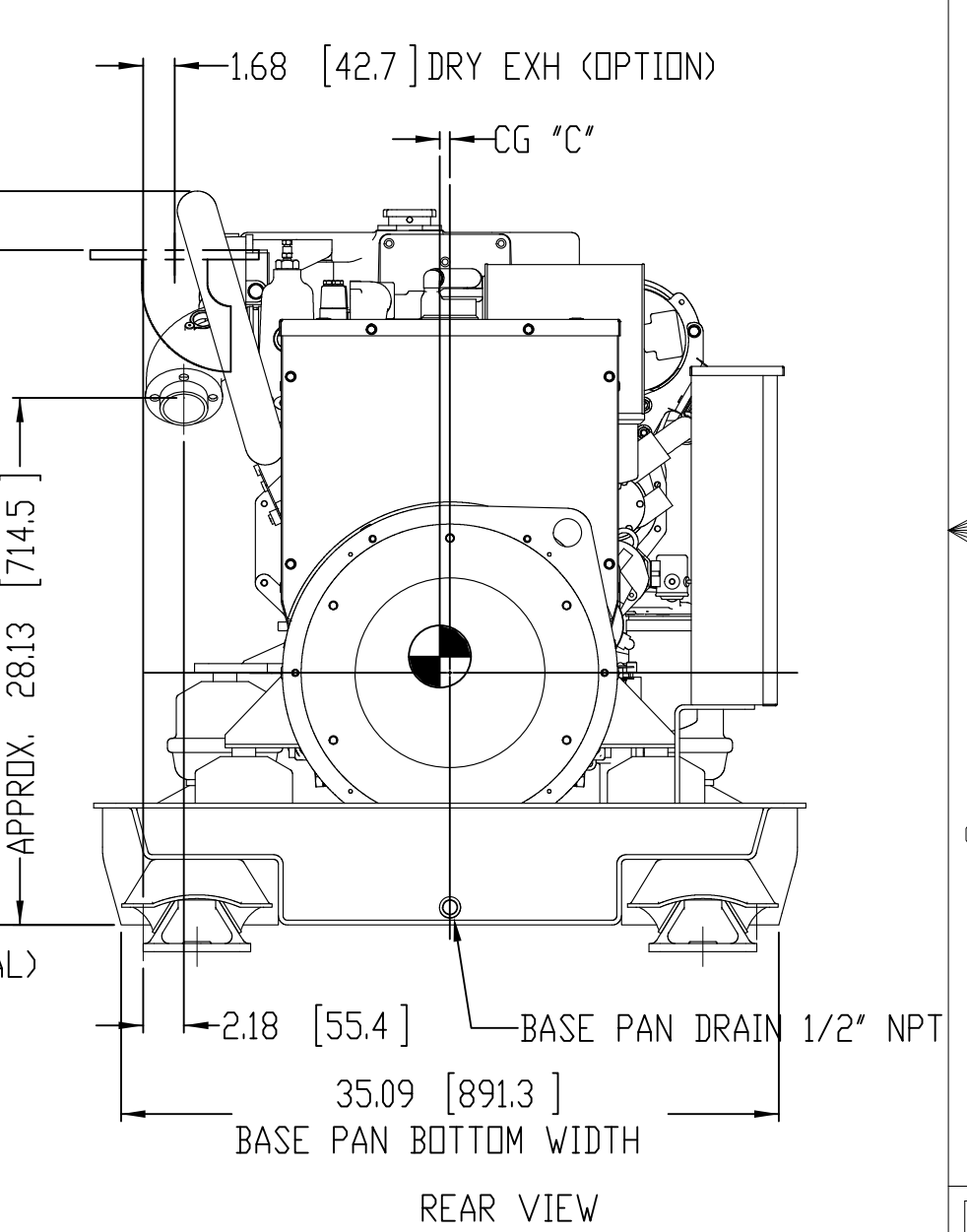
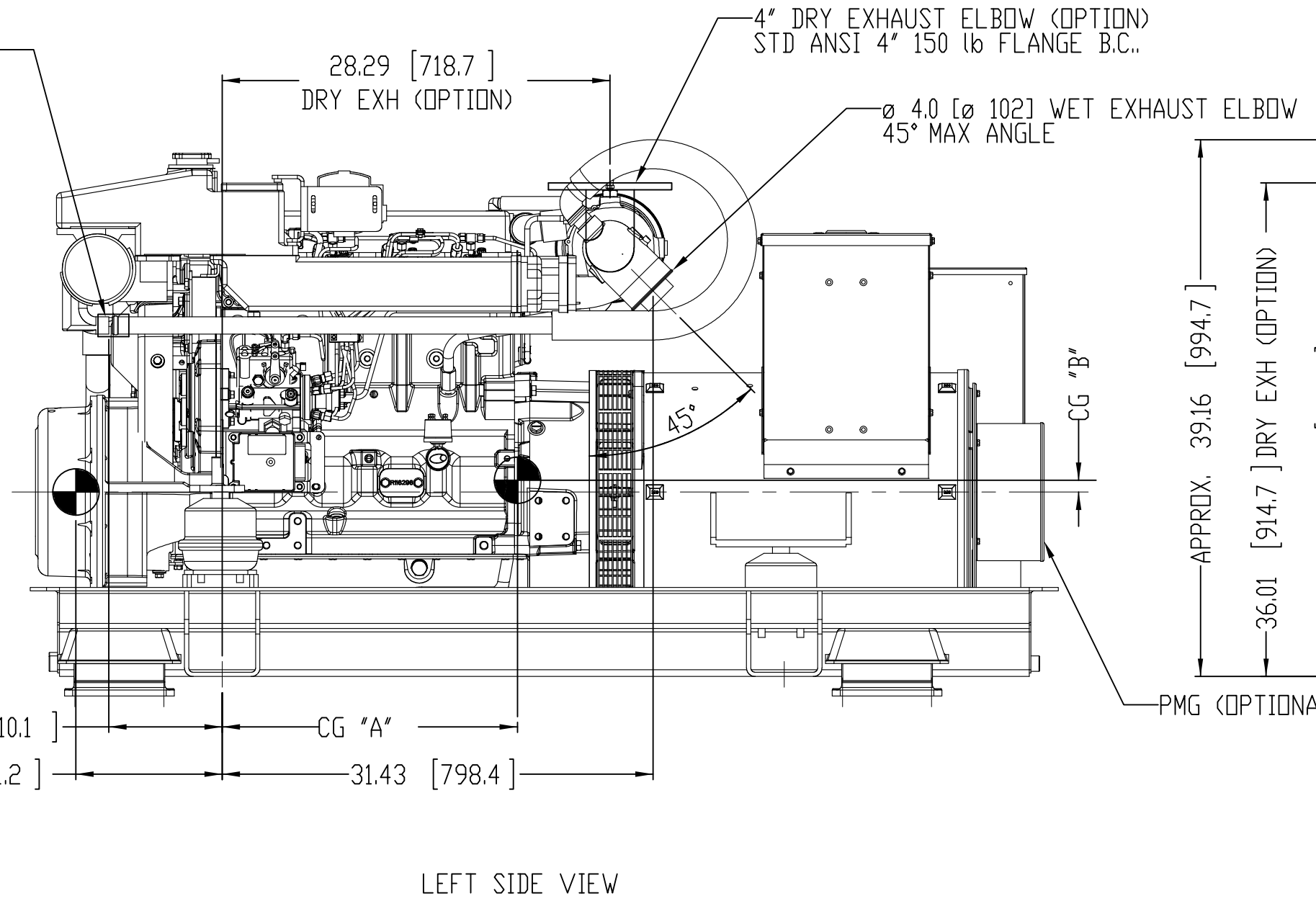
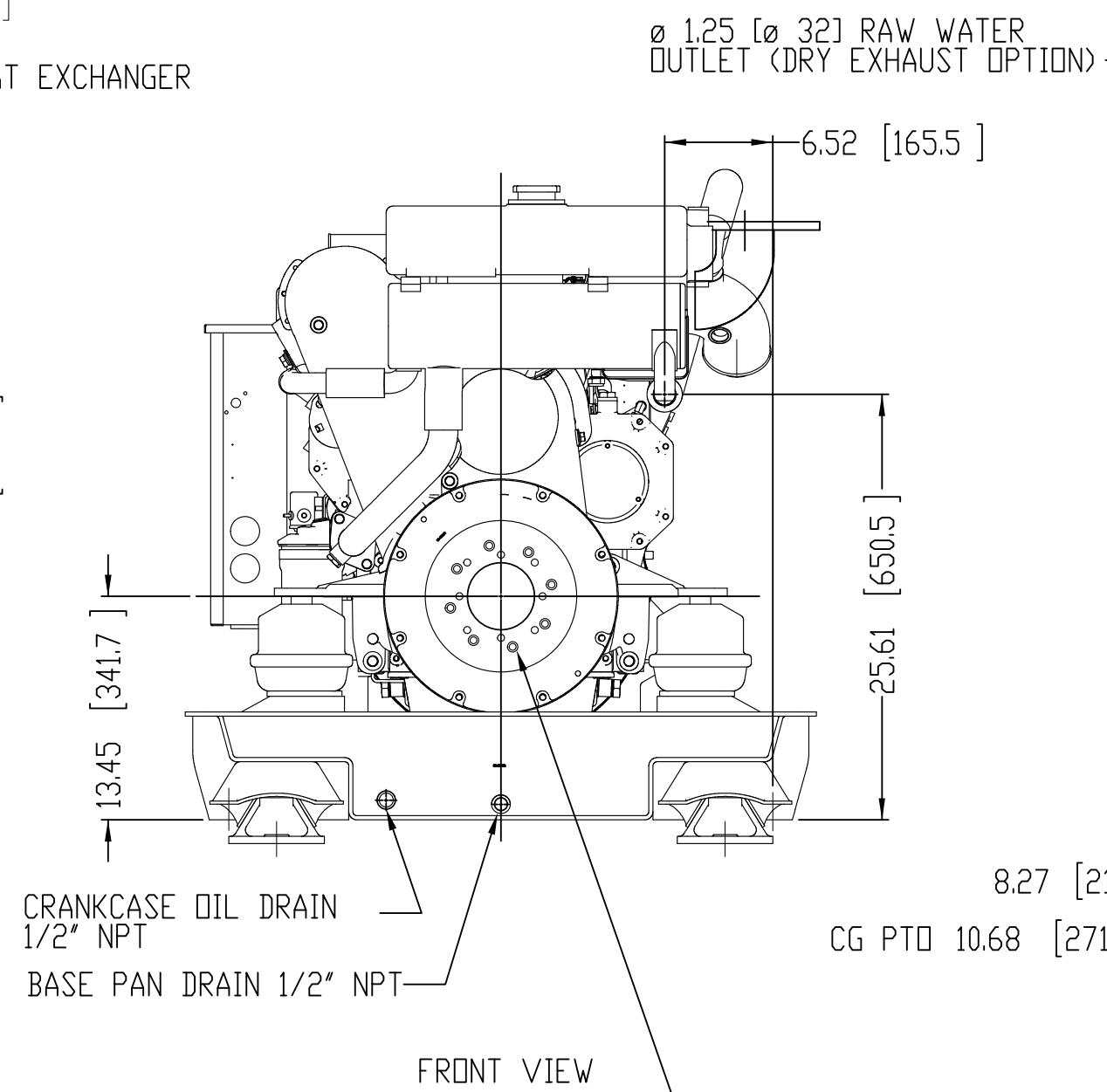
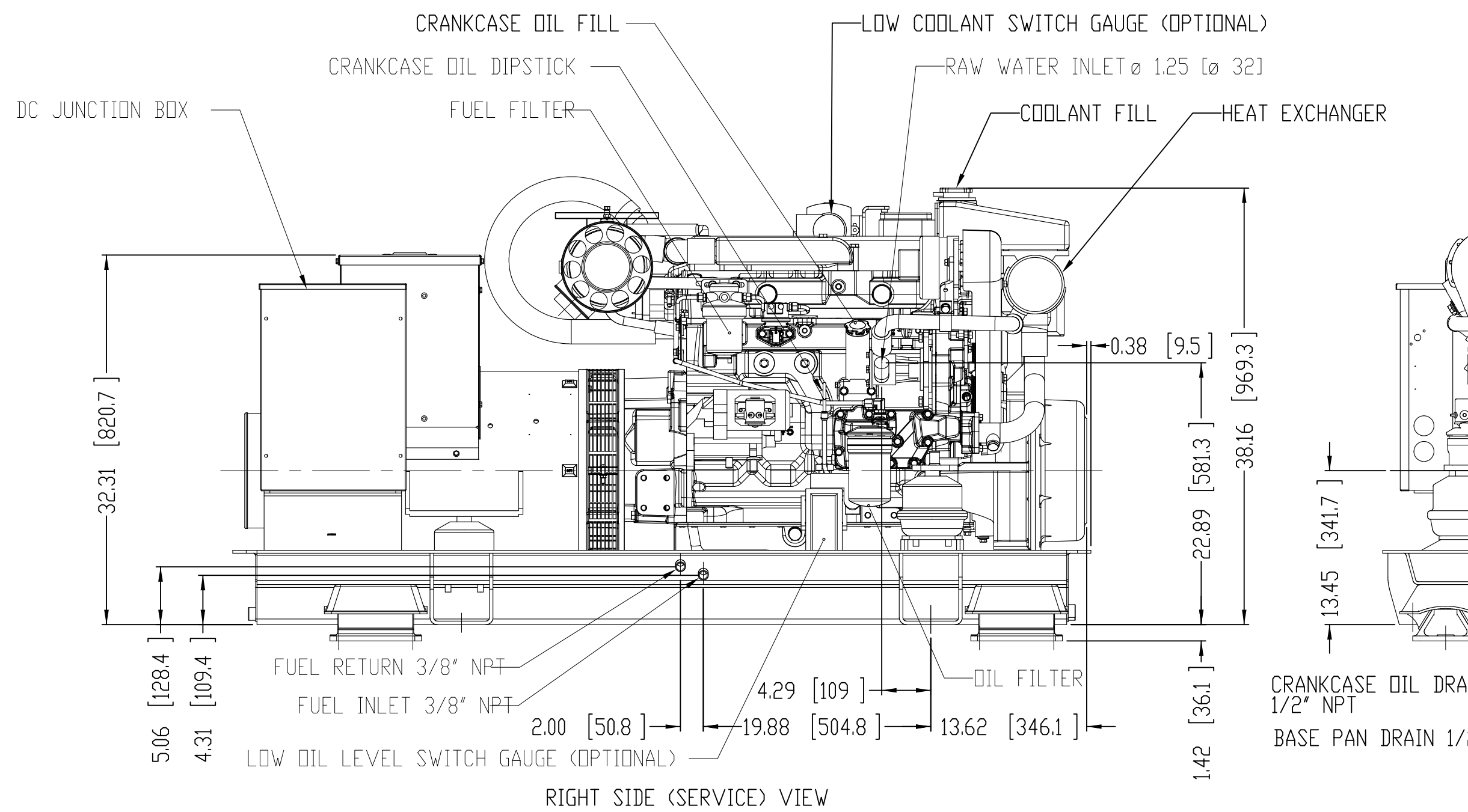
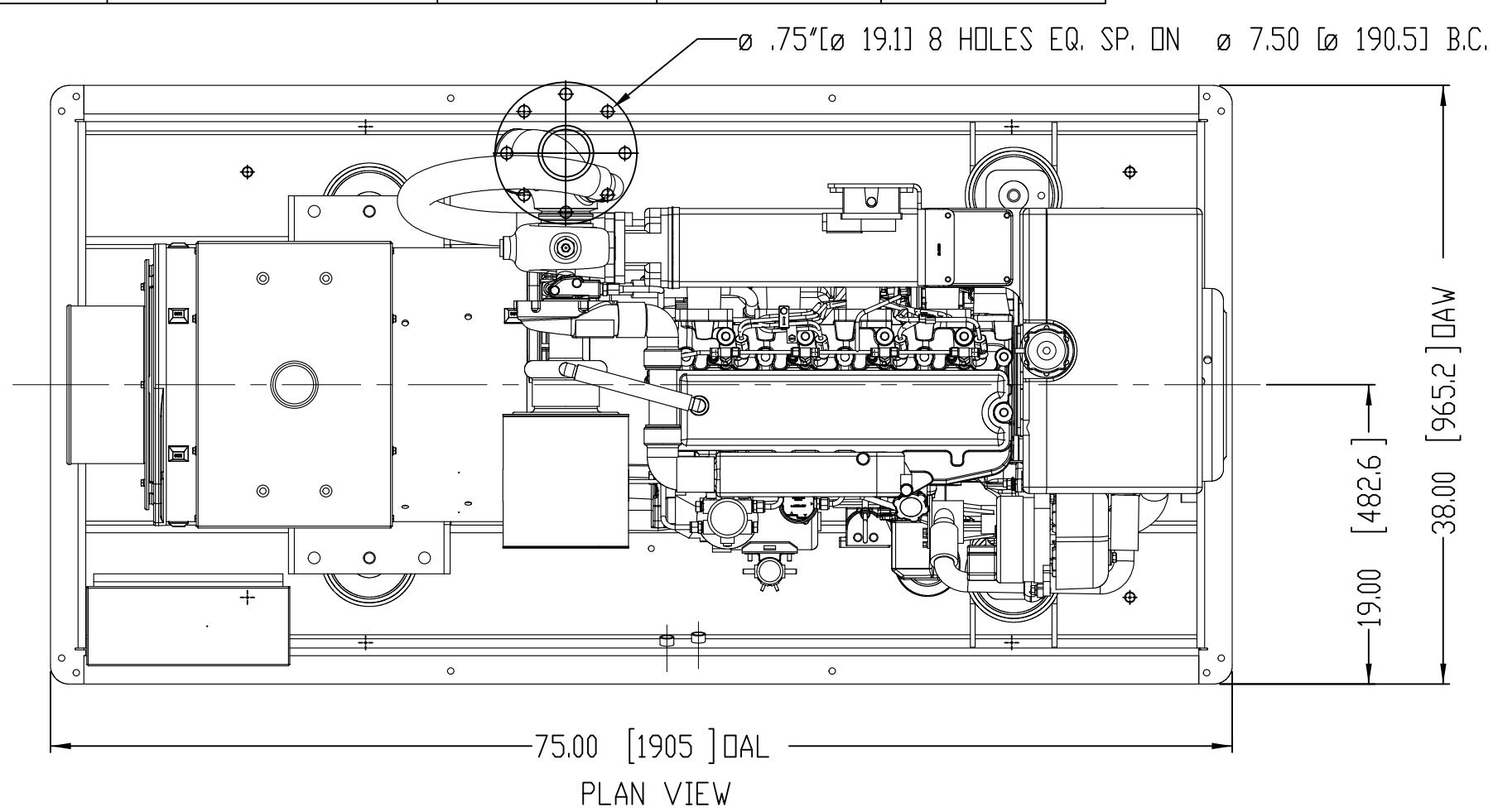

PTO PUMP MTG FACE (OPTIONAL)
 H36 'B' SPLINE 13T 16/32 D.Ø. 7/8 SPLINE
 -DR-
 H36 'C' SPLINE 14T 12/24 D.Ø. 1-1/4' SPLINE

NOTE:
 1. CENTER OF GRAVITY VALUES DO NOT INCLUDE PTO/CLUTCH ASSEMBLY.
 2. PTO ADAPTER/CLUTCH ASSY WEIGHS APPROX. 116 lbs [52 kg].
 3. CUSTOMER MUST RECALCULATE CG FOR ADDITION OF HYDRAULIC PUMP.
 4. WEIGHT DATA MAY VARY UPON ADDITION OF OPTIONAL EQUIPMENT.

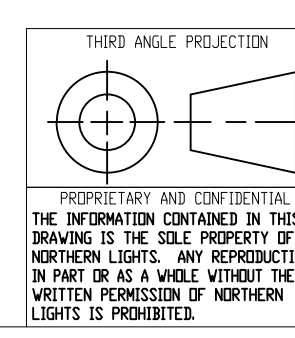

UNLESS OTHERWISE SPECIFIED DIMENSIONS ARE IN MILLIMETERS		NAME	DATE	4420 14th AVE. N.W. Seattle, WA 98107 (206) 789-3880 www.northern-lights.com	
ANGULAR:	MACH ± 0.5°	DRAWN	LTP		4/3/13
BEND ± 1.0°	X ± 0.15	CHECKED	TAH		4/5/13
XX ± 0.3	INTERPRET GEOMETRIC TOLERANCING PER: ASME Y14.5M	ENG APPR.			
MATERIAL:	FINISH:	MFG APPR.	QA:	COMMENTS:	
DO NOT SCALE		SCALE: 1:10		WEIGHT: SEE TABLE	

TITLE: **INSTALLATION DIMENSIONS**
 M1064T1 3 AND 1 Ø / T2 3Ø ONLY
 SIZE: PART NO. D-4649
 DWG NO. D-4649
 SHEET 1 OF 1