

MODEL	RATING	FREQUENCY	PHASE
M944T3	40 kW	60 Hz	3
	38 kW	60 Hz	1

ITEM	WEIGHT	C.G.		
		X	Y	Z
GENSET	717 kg [1580 LBS.]	293	282	477
GENSET W/P.T.O	758 kg [1672 LBS.]	293	278	448
GENSET W/HD P.T.O	777 kg [1713 LBS.]	293	277	433

NOTE: GENSET WEIGHT INCLUDES COOLANT & OIL.

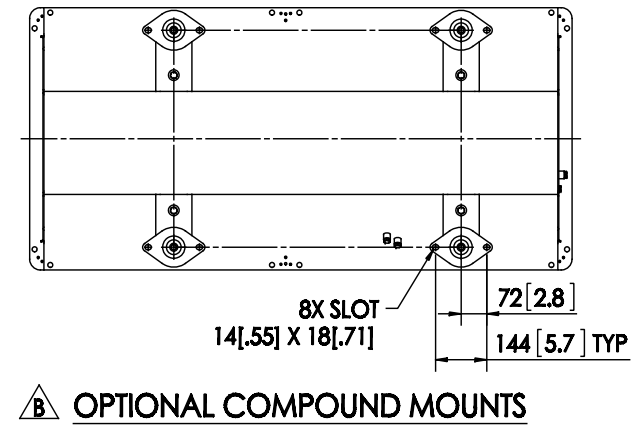
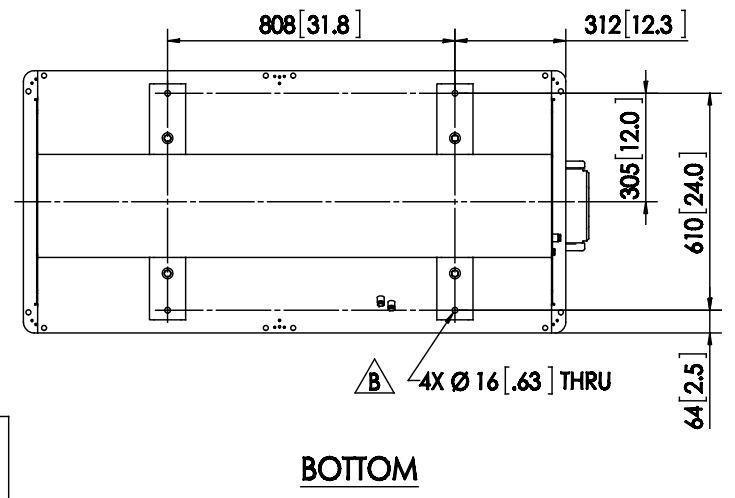
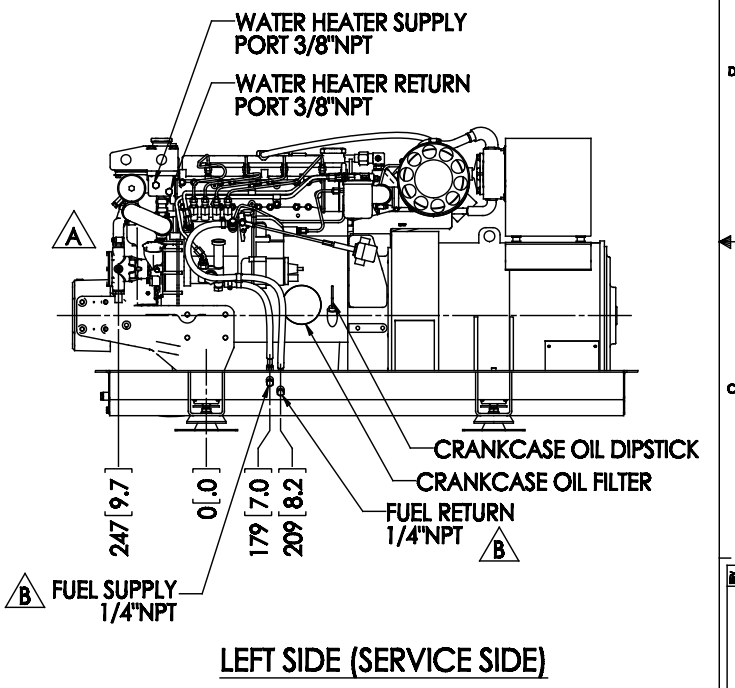
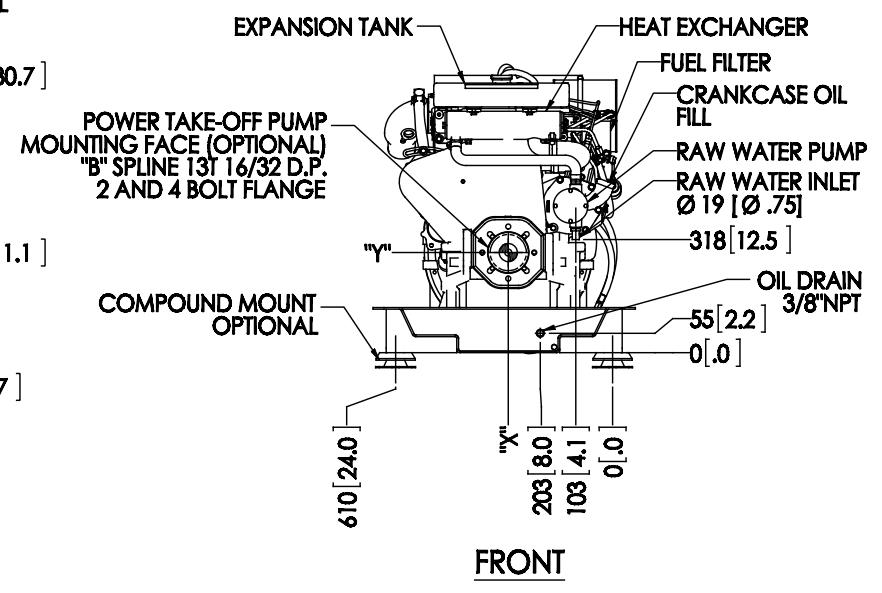
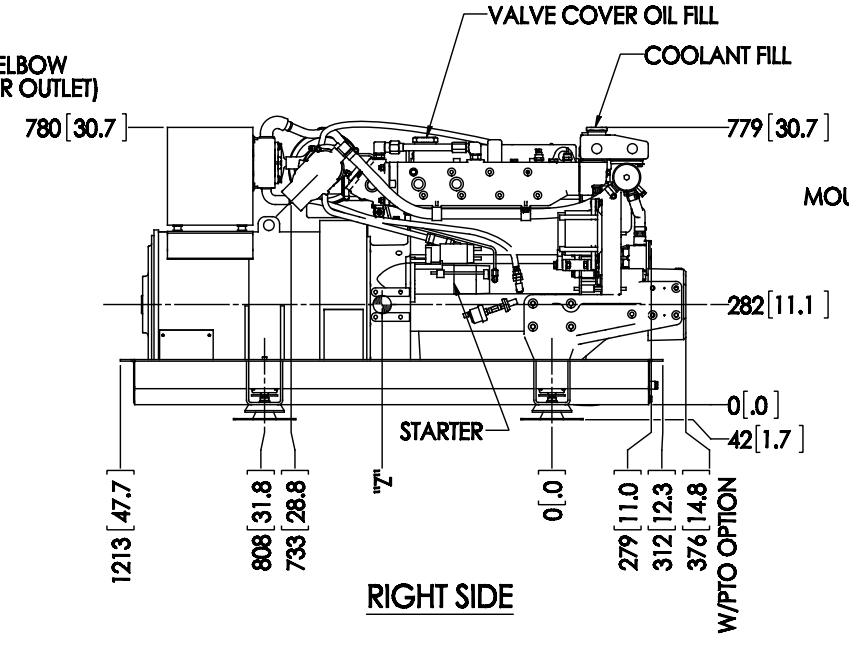
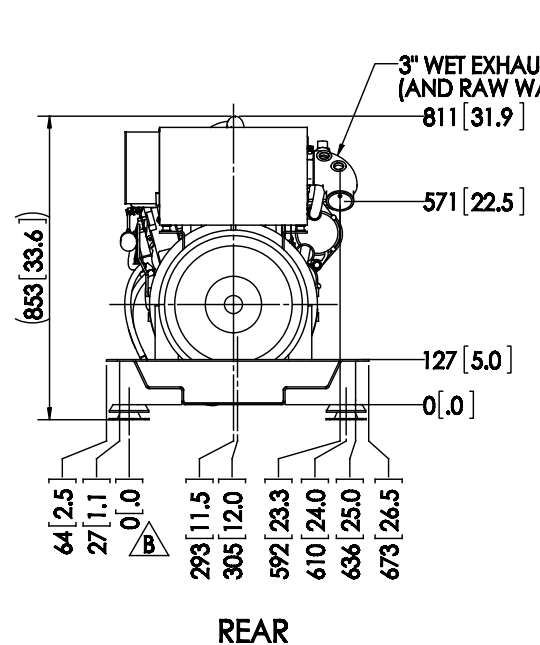
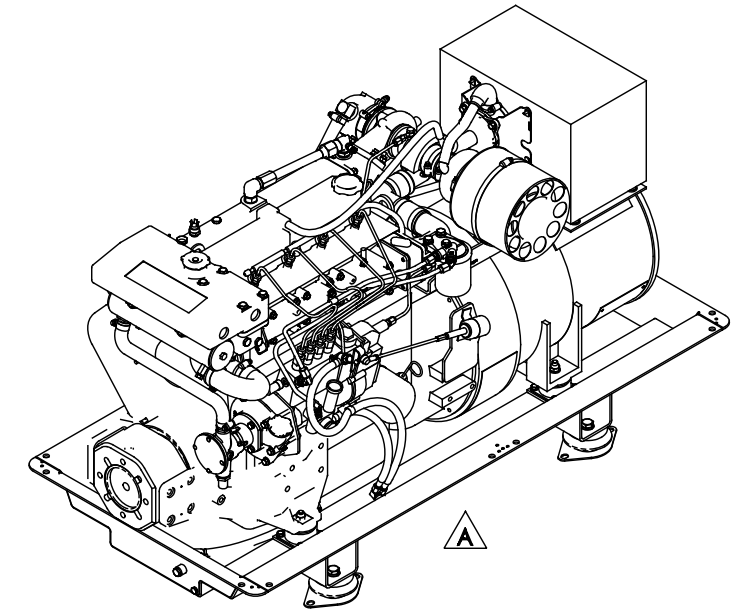
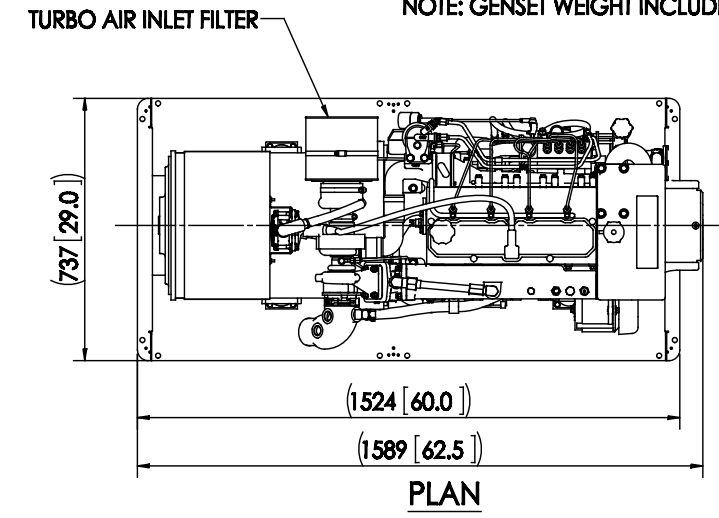

THE DIMENSIONS ON THIS DRAWING ARE SUBJECT TO CHANGE. PLEASE CONTACT NORTHERN LIGHTS INC. TO BE SURE YOU HAVE THE MOST CURRENT REVISION.

REV.	DESCRIPTION	DATE	BY	CHECKED
B	UPDATED WEIGHT, ADDED WEIGHT & C.G. TABLE, CORRECTED ORIGINATE DIMENSIONS IN REAR VIEW, FUEL SUPPLY & RETURN NOW 1/4"NPT WAS 3/8"NPT, UPDATED MODEL INFO, ECH 3895	11/9/2015	MG	TAH
A	CORRECTED FUEL SUPPLY AND RETURN LINES IN LEFT SIDE VIEW, CHANGED ISOMETRIC VIEW TO SKETCH SERVICE SIDE, SEE ECH 322A	5/9/2014	MG	TAH

UNLESS OTHERWISE SPECIFIED:	NAME	DATE
DRAWN	MG	04/24/14
CHECKED	TAH	04/24/14
ENG APPR.		
MFG APPR.		
QA		
COMMENTS		

4420 14th AVE. N.W., Seattle, WA 98107 (206) 789-3880 www.northern-lights.com	
NORTHERN LIGHTS	
TITLE: INSTALLATION DIMENSIONS M944T3	
SIZE: PART NO. D	DWG. NO. D-4753
SCALE: 1:10	WEIGHT: SHEET 1 OF 1

D-4753