

ESTIMATED WEIGHTS		
ITEM	kg	LBS
GENSET (W/COOLANT & OIL)	2470	5450
SOUND ENCLOSURE	363	800
COMPOUND MOUNTS	48	105
C-SPLINE PTO	75	165

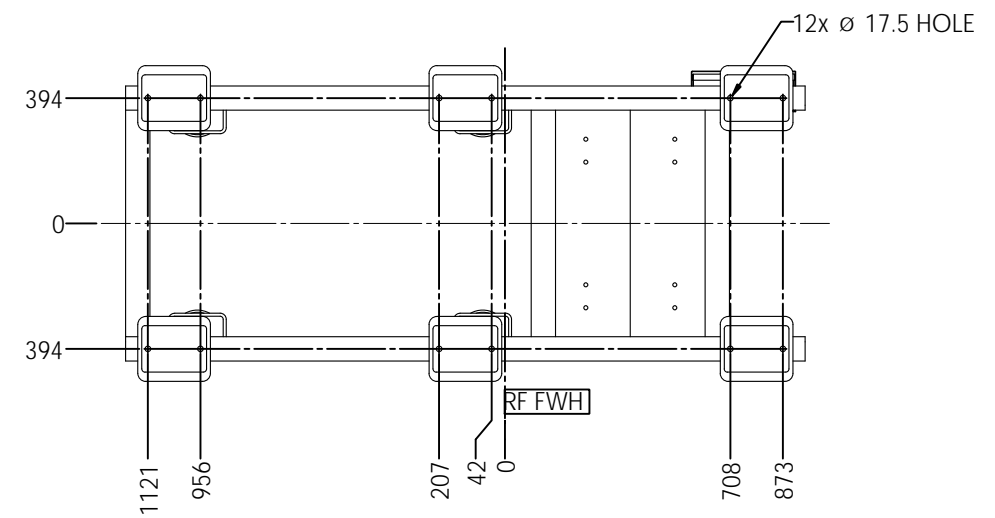

COMPOUND MOUNT BOLT PATTERN

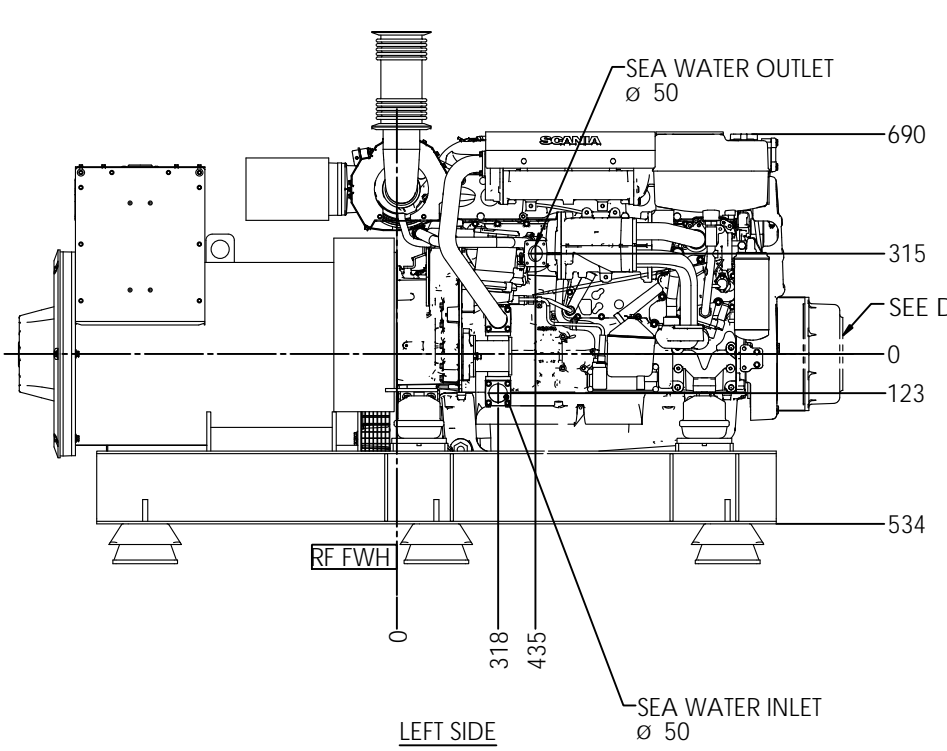

LEFT SIDE

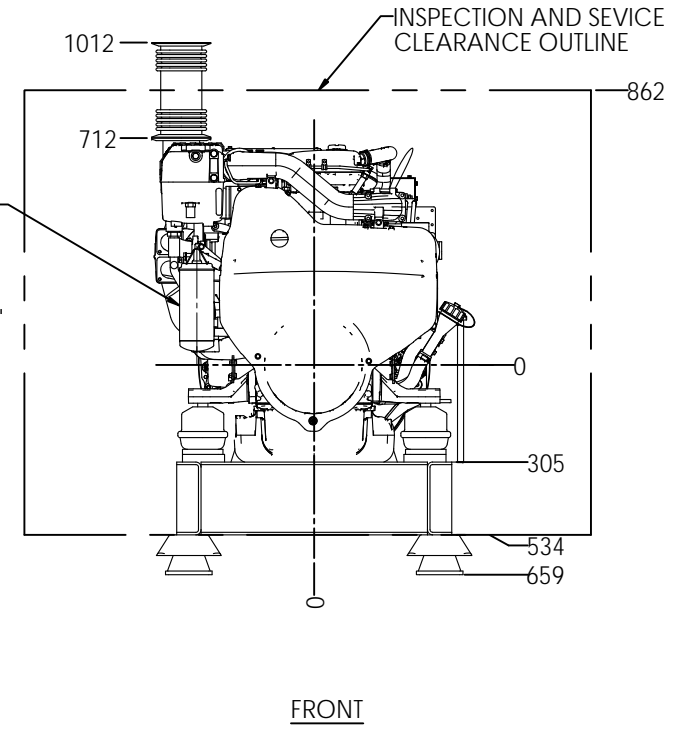

FRONT

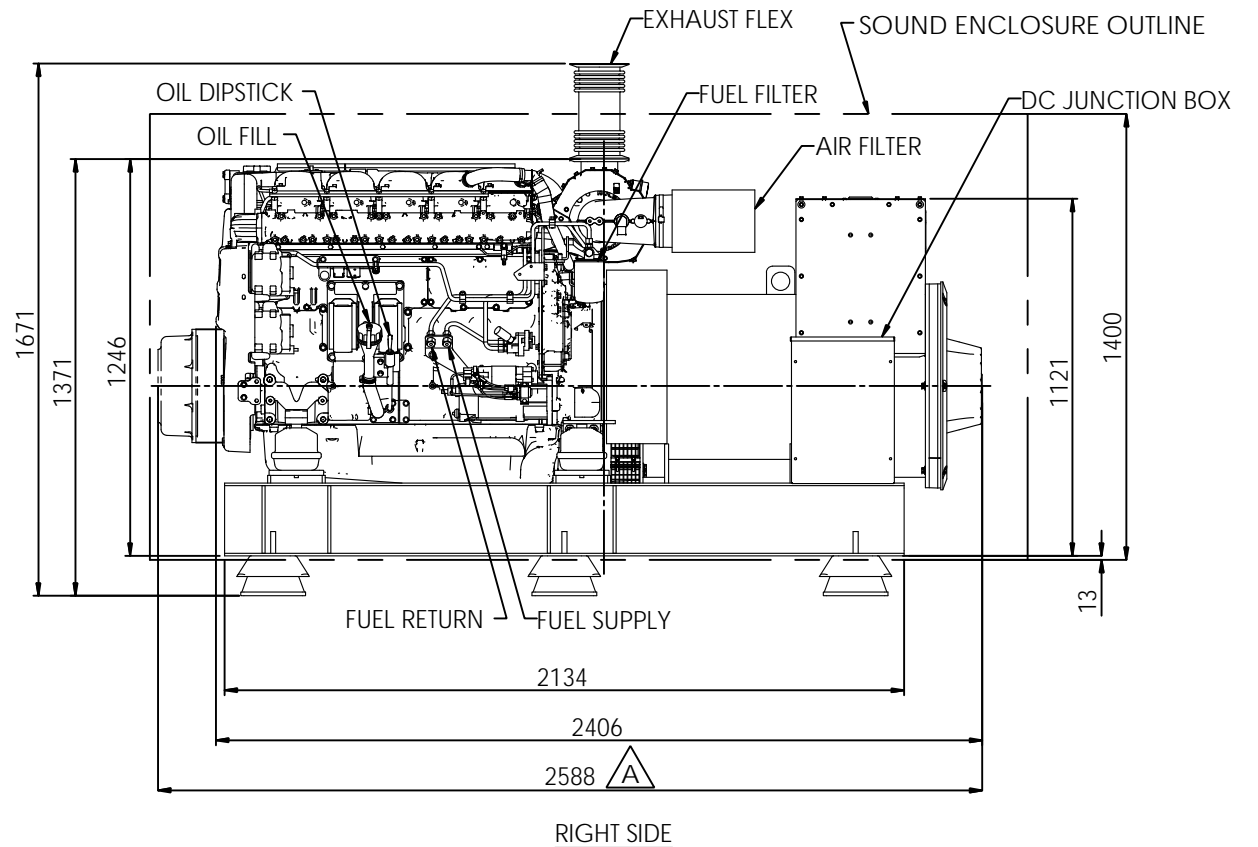

RIGHT SIDE

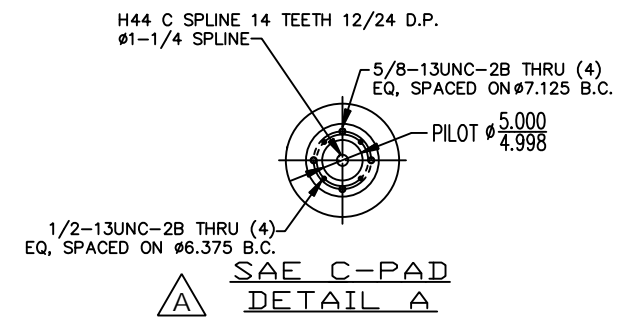

SAE C-PAD DETAIL A

THE DIMENSIONS ON THIS DRAWING ARE SUBJECT TO CHANGE. PLEASE CONTACT NLI TO BE SURE YOU HAVE THE MOST CURRENT REVISION.

REV	DESCRIPTION	DATE	BY	CHECKED
B	ADDED WEIGHT TABLE. ECN 3529.	9/17/2015	MG	TAH
A	ADDED OPTIONAL C-SPLINE PTO. ECN 3527.	9/16/2015	MG	TAH
REV	DESCRIPTION	DATE	BY	CHECKED

UNLESS OTHERWISE SPECIFIED:	NAME	DATE
DIMENSIONS ARE IN MILLIMETERS	MG	1/20/15
TOLERANCES:	TAH	1/20/15
ANGULAR: MACH: ± 0.5° BEND ± 1.0°		
X: ± 2		
INTERPRET GEOMETRIC TOLERANCING PER: ASME Y14.5M		
MATERIAL:		
FINISH:		
DO NOT SCALE		

		4420 14th AVE. N.W. Seattle, WA 98107 (206) 789-3880 www.northern-lights.com	
<b>TITLE: INSTALLATION DIMENSIONS</b> <b>M1305A32</b>			
SIZE	PART NO.	DWG. NO.	REV
D		D-4826	B
SCALE: 1:12	WEIGHT:	SHEET 1 OF 1	