

MODEL	RATING	FREQUENCY	PHASE
M40C3.14	40 kW	60 Hz	3

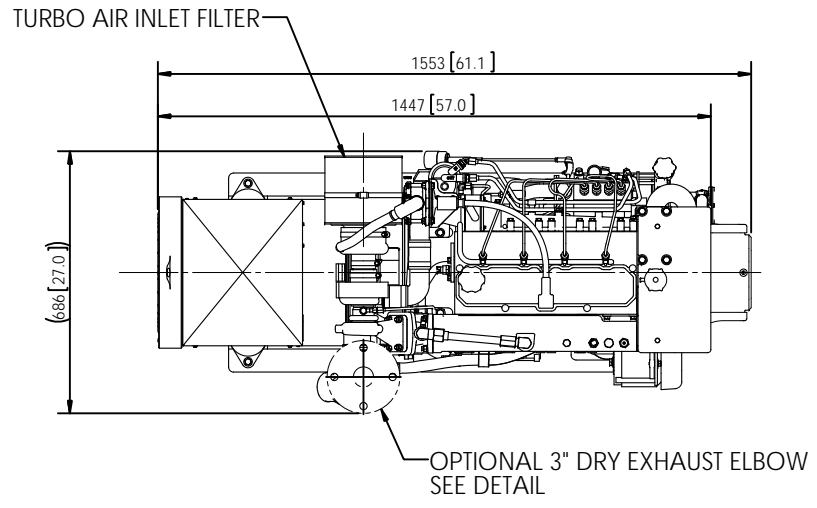

PLAN

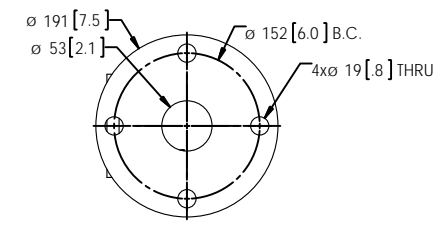

OPTIONAL DRY EXHAUST ELBOW DETAIL

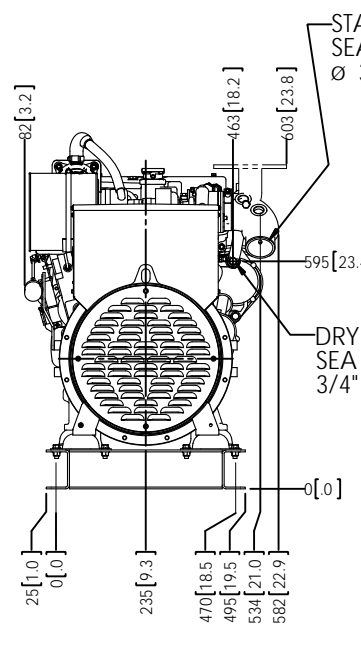
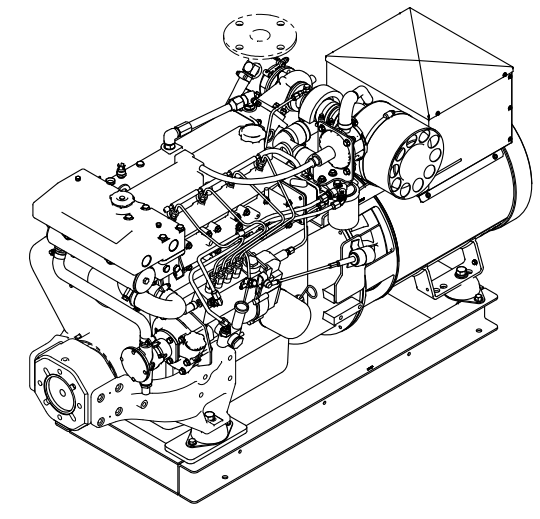

REAR

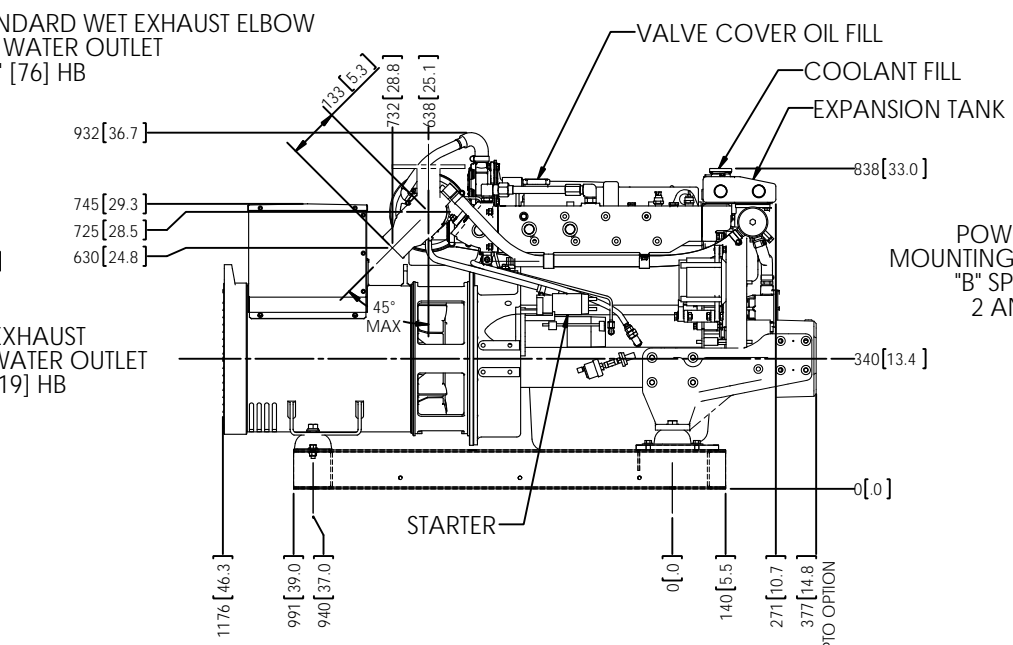

RIGHT SIDE

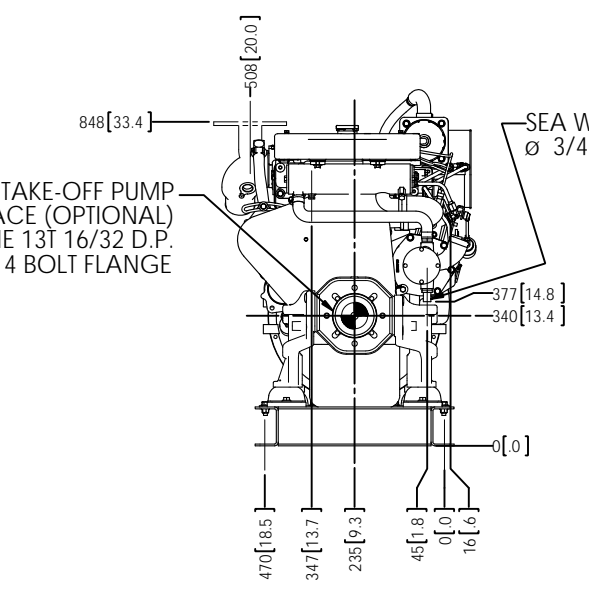

FRONT

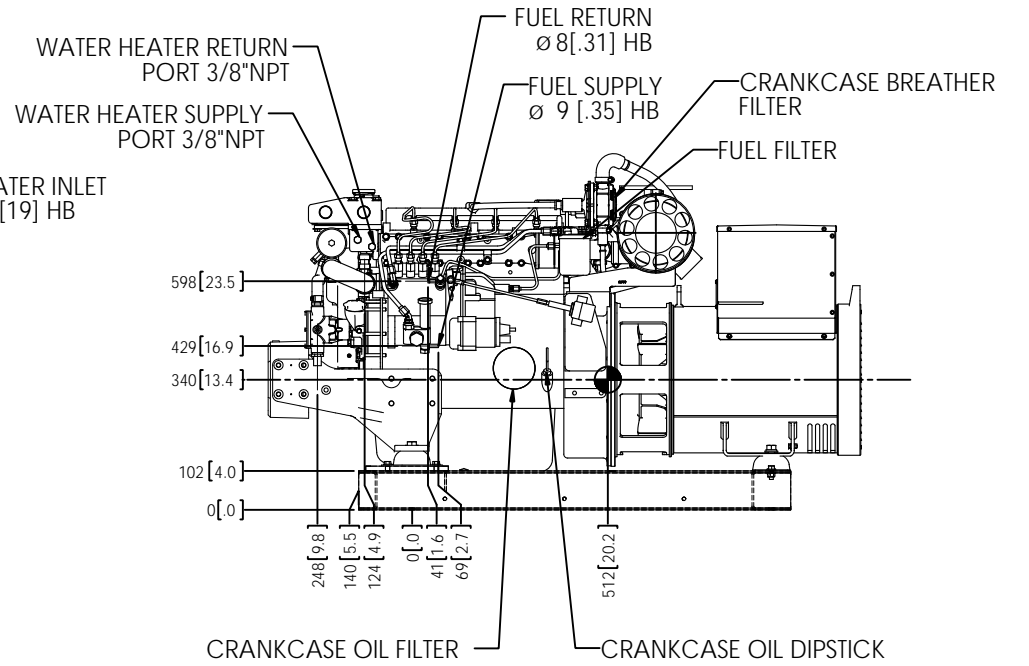

LEFT SIDE (SERVICE SIDE)

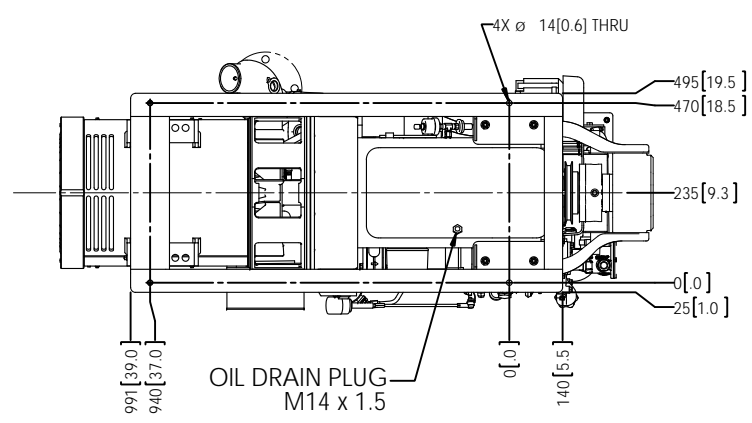

BOTTOM

- NOTES
- WEIGHTS: GENSET - 626 kg [1380 lbs]
GENSET W/PTO - 658 kg [1450 lbs]
 - WEIGHTS ARE WITH OIL, NO COOLANT.
 - C.G. DOES NOT INCLUDE PTO ASSEMBLY.

THE DIMENSIONS ON THIS DRAWING ARE SUBJECT TO CHANGE. PLEASE CONTACT NORTHERN LIGHTS INC. TO BE SURE YOU HAVE THE MOST CURRENT REVISION.

	UNLESS OTHERWISE SPECIFIED:	NAME	DATE		4420 14th AVE. N.W. Seattle, WA 98107 (206) 789-3880 www.northern-lights.com
	DIMENSIONS ARE IN MILLIMETERS TOLERANCES: ANGULAR: MACH ± 0.5° BEND ± 1.0° X ± 2 XX ± 1 INTERPRET GEOMETRIC TOLERANCING PER: ASME Y14.5M	DRAWN	MG		
PROPRIETARY AND CONFIDENTIAL THE INFORMATION CONTAINED IN THIS DRAWING IS THE SOLE PROPERTY OF NORTHERN LIGHTS. ANY REPRODUCTION IN PART OR AS A WHOLE WITHOUT THE WRITTEN PERMISSION OF NORTHERN LIGHTS IS PROHIBITED.	DO NOT SCALE	CHECKED	TAH	04/01/15	TITLE: INSTALLATION DIMENSIONS M40C3.14 H.E.
		ENG APPR.			