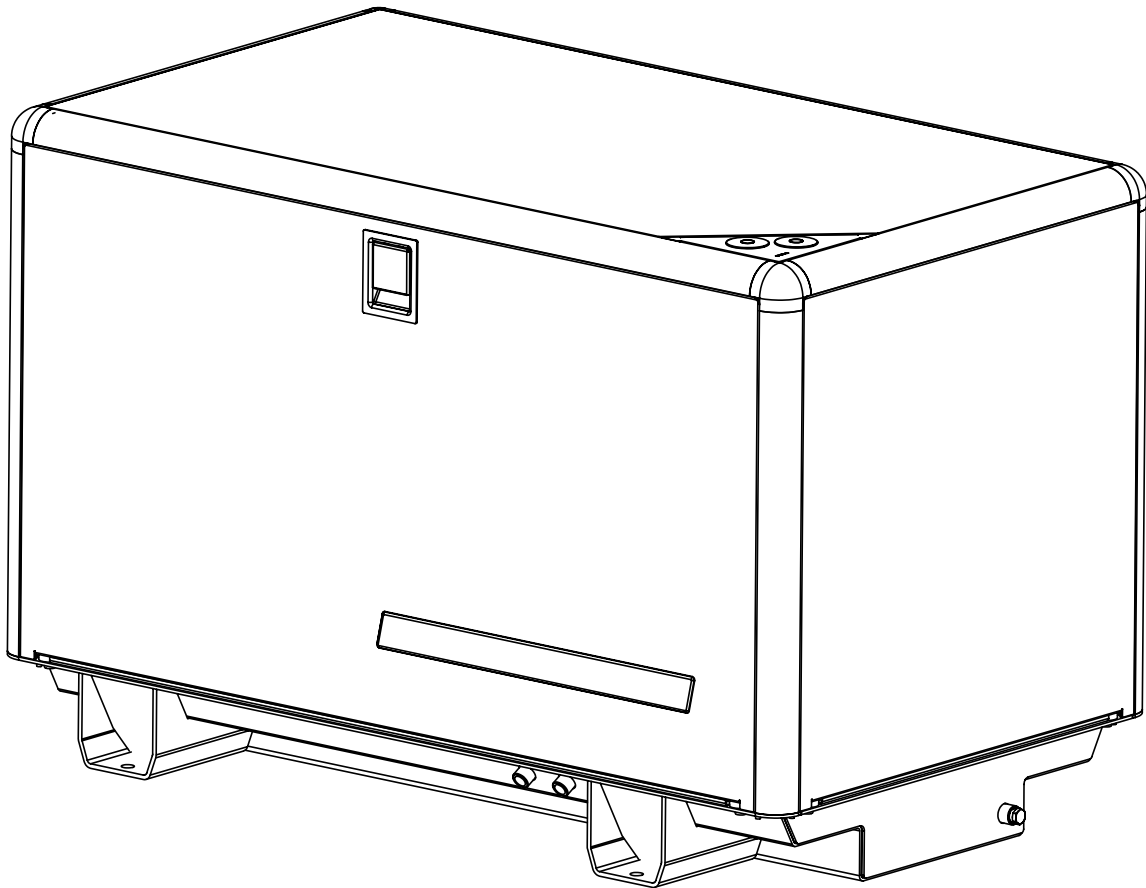




**NORTHERN LIGHTS**

# M843NW3

## Soundshield Assembly Instructions



**Corporate Headquarters**

4420 14th Avenue NW  
Seattle, WA 98107  
Tel: (206) 789-3880  
Fax: (206) 782-5455

**Alaska Branch Office**

1200 West International  
Airport Road  
Anchorage, AK 99519  
Tel: (907) 562-2222  
Fax: (907) 563-1921

**Southeastern U.S.A.**

1419 W Newport Center Dr  
Deerfield Beach, FL 33442  
Tel: (954) 421-1717  
Fax: (954) 421-1712

**East Coast Branch**

15 Aegean Dr.  
Suite 4  
Methuen MA 01844  
Tel: (978) 475-7400  
Fax: (978) 475-7745

**Gulf Branch**

19 Veterans Memorial Blvd.  
Kenner, LA 70062  
Tel: (504) 360-2180  
Toll Free: (800) 843-6140



# M843NW3 SOUND SHIELD

ITEM	DESCRIPTION	NLI P/N	QTY	NOTES
1	TOE BRACKET	23-78007	4	
2	#10-32 MACHINE SCREW x 1/2" LONG, STAINLESS STEEL	12-00000	8	
3	#10 FLATWASHER, USS STAINLESS STEEL	15-70002	8	
4	#10-32 NYLOCK HEX NUT, STAINLESS STEEL	14-00032	8	
5	EXTRUSION, VERTICAL	05-73127	4	
6	BOLTING ASSEMBLY, SHORT, STAINLESS STEEL	00-75714	20	
7	BOLTING ASSEMBLY, LONG, STAINLESS STEEL	05-72003	8	
8	PANEL RETAINER BLOCK, SINGLE NOSE, NYLON	23-78016	4	
9	EXTRUSION, HORIZONTAL, SIDES	05-73129	2	
10	EXTRUSION, HORIZONTAL, ENDS	05-73128	2	
11	CORNER CASTING	05-70001	4	
12	TOP PANEL ASSEMBLY	05-73136	1	
13	PENETRATION PANEL ASSEMBLY	05-78022	1	
14	REAR PANEL RETAINING BRACKET	23-78003	2	
15	JUNCTION BOX SUPPORT BRKT COVER ASSEMBLY	05-78636	1	
16	REAR PANEL ASSEMBLY	05-73133	1	
17	LEFT SIDE PANEL ASSEMBLY	05-73132	1	WITH VENT BOX
18	FRONT PANEL ASSEMBLY	05-73134	1	
19	RIGHT SIDE PANEL ASSEMBLY	05-73131	1	NO VENT BOX
20	PLUG, BASE PAN MOUNTING FOOT POCKET	55-73138	4	
21	GROMMET, 1-1/8" ID x 1-7/8" OD PENETRATION PLATE	00-70083	2	CUSTOMER OPTION
22	SOUND FOAM, PENETRATION PLATE OPTION	55-78066	2	CUSTOMER OPTION
23	KIT, WET EXHAUST OUTLET TUBE	27-33110	1	

## Specifications:

Enclosure (Installed on Generator Base):

Length (OA).....39.37 in (1000 mm)

Width.....22.83 in (580 mm)

Height.....25.75 in (654 mm)

Assembled Weight:

75 lbs (34 kg) shield only

822 lbs (372.8 kg) with generator set

**1**

Prior to assembly, inspect all components for damage. Report any damage to the shipping company. Check the packing list in the back of this manual to be sure all parts are included.

**2**

Select a mounting location in accordance with the guidelines in the IM1000 Installation Manual (supplied with the generator set). The generator set must typically be mounted on a rigid, flat surface above a strong structure, such as the vessel's stringers, to minimize vibration transference to the hull.

Note that the generator set is designed for single side service. When viewed from the rear, the right hand side is the service side and should be exposed for easy maintenance access.

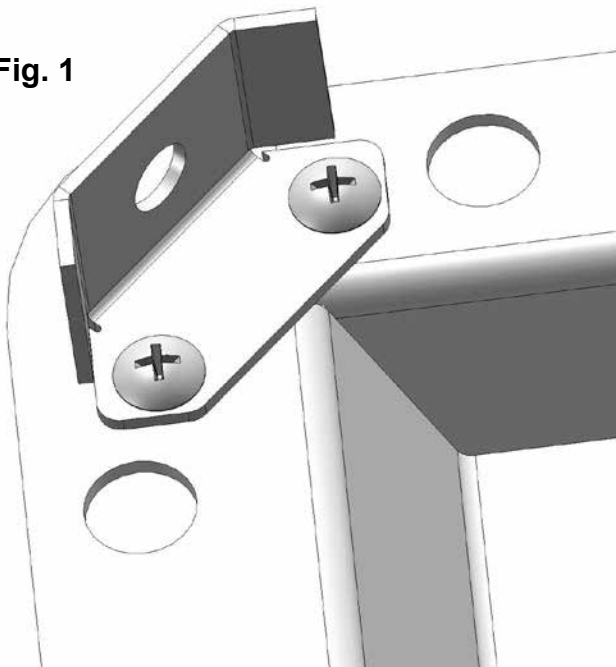
**3**

Install the generator set in the vessel as near to a level attitude as possible. Ensure that the enclosure's left hand side and rear are at the recommended distances (6 inch recommended, 4 inch minimum.) from the vessel's bulkheads.

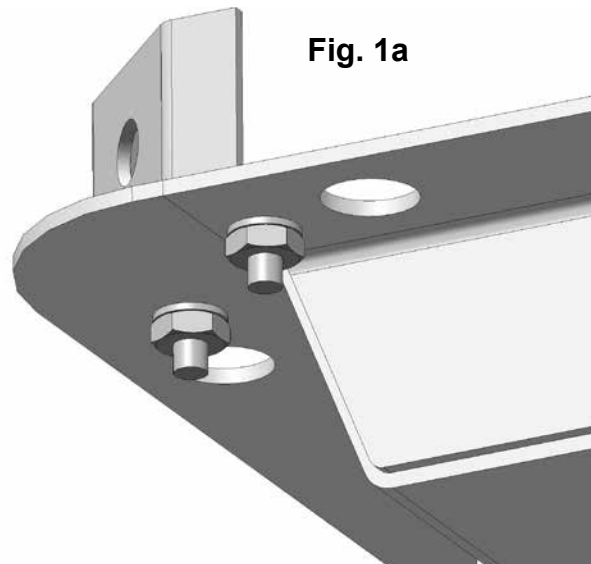
**AVOID POSITIONING THE ENCLOSURE INTO CORNERS WITH OVERHEAD BLOCKED TO REDUCE CHANCE OF INTAKE/EXHAUST AIR RECIRCULATION OUTSIDE THE SHIELD.**

Install toe bracket (item 1) to each corner of the genset base flanges with machine screws, flatwashers and nylock hex nuts (Items 2,3, and 4) into the holes indicated in Fig 1 and Fig 1a.

**Fig. 1**

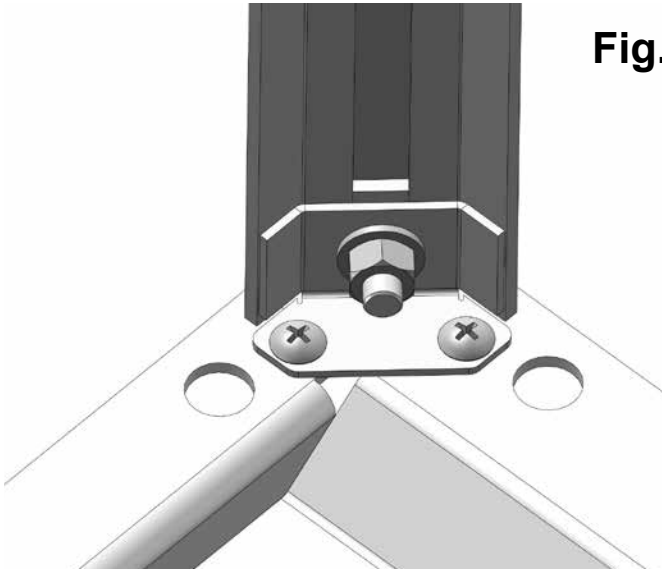


**Fig. 1a**

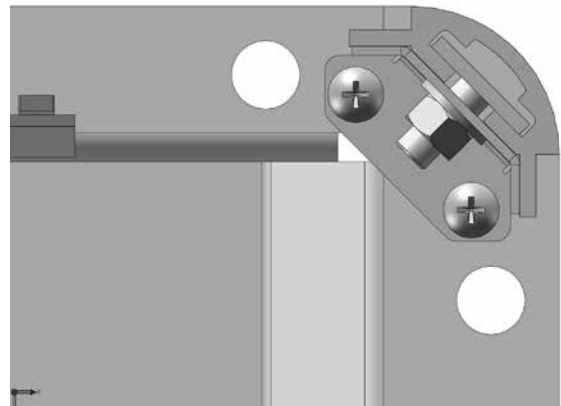


**4**

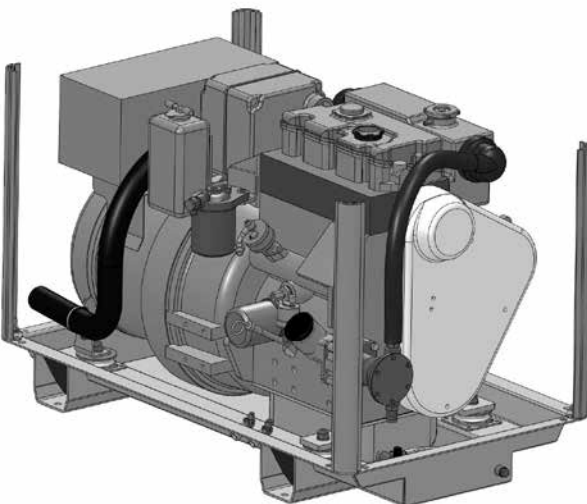
Install the four vertical extrusions (item 5) with four bolting assemblies (item 6) per FIGS 2 and 2a. Don't fully tighten these nuts until final assembly. Extrusion should be loose enough for adjustment during the building process. You should have what appears in Fig 3 at this time.



**Fig. 2**



**Fig. 2a**



**Fig. 3**

5

Before the top of the enclosure frame can be added, the front and left hand side panel retainer blocks (item 8) must be installed.

The panel retainer blocks (item 8) are anchored to the vertical extrusion with a single long bolting assembly (item 7). For now, loosely install these blocks to the position and orientation indicated in Fig 4. The front left corner receives TWO of these blocks (item 8), while the front right and the left rear receive only ONE each. You will go back later for final positioning and tightening of these blocks.

SEE FIG 4A.

Fig. 4

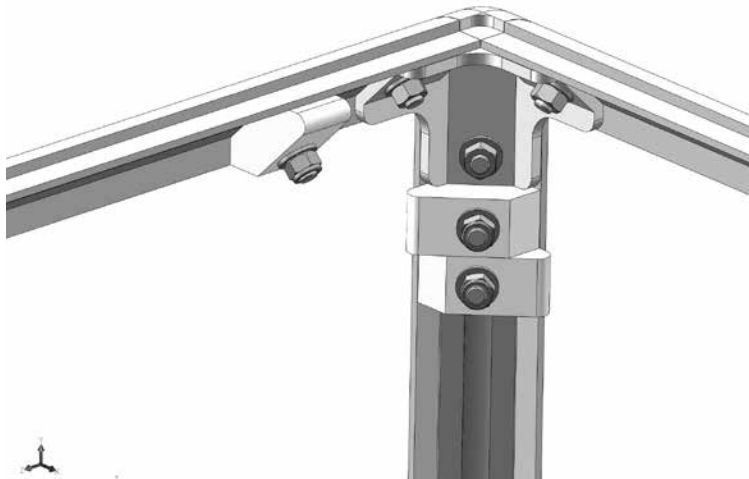
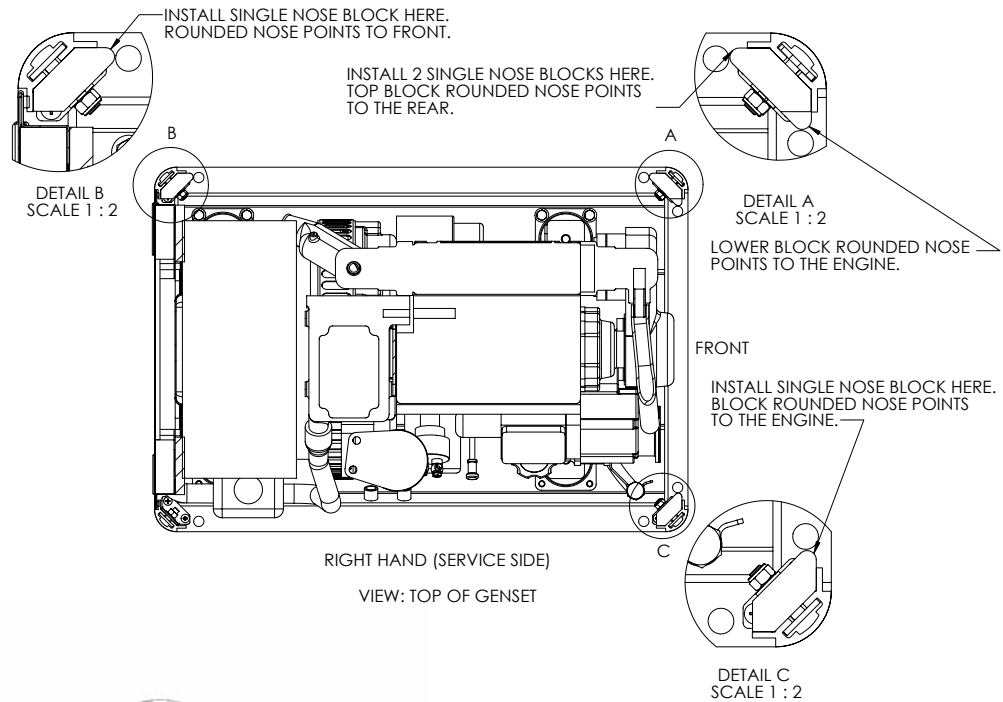


Fig. 4a



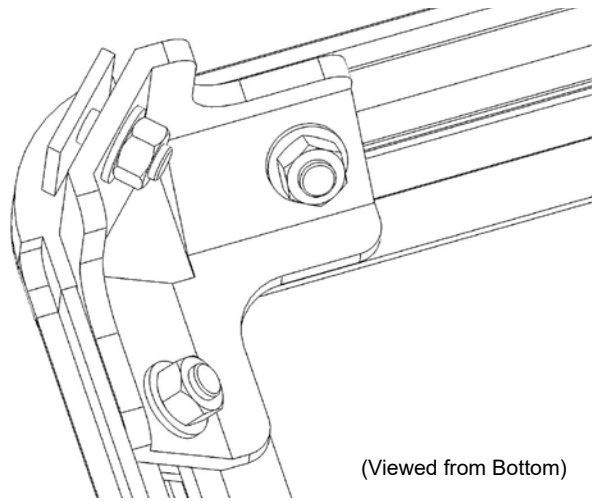
The top frame of the enclosure is pre-assembled with the top panel installed (items 6, 7, 8, 9, 10, 11, 12, 13, & 14.) For now, pop out the top panel (item 12) only from this assembly to facilitate installation process.

Note the available leg on each corner casting (item 11.) Loosely install a short bolting assembly (item 6) to each of these legs. SEE FIG 5.

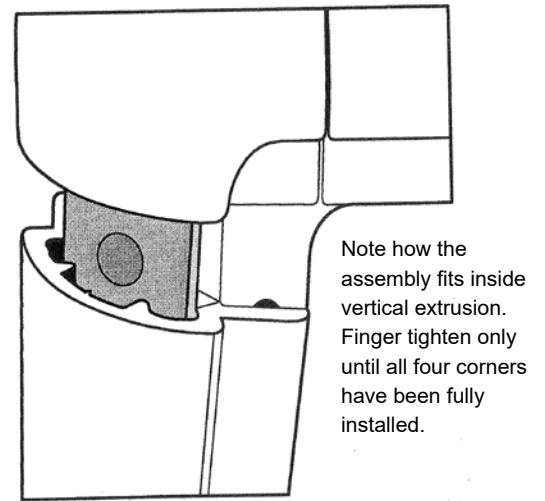
Orient the top frame (items 6, 7, 8, 9, 10, 11, 12, 13, & 14.) with the triangular shaped penetration plate (item 13) toward the front of the genset and unattached corner casting legs facing down. Install each leg into the top of each vertical extrusion as shown in FIG 5a.

Check frame for squareness and commence tightening all bolting assemblies progressively and gradually all the while ensuring that the top frame is pushed firmly down into vertical extrusions, and no excessive gaps remain.

**Fig. 5**



**Fig. 5a**



**6**

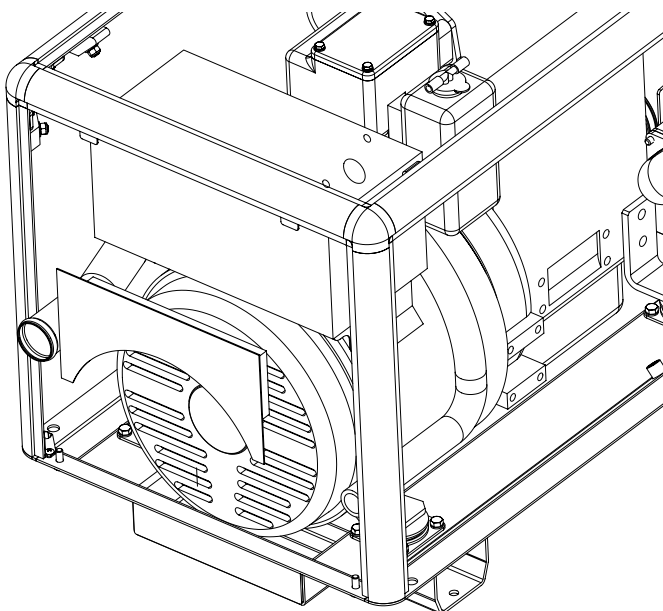
Now install the junction box support cover (item 15) into place. Note the shape of the foam backing and see the space beneath the generator junction box at the rear of the genset. SEE FIG 6.

Insert the foam block portion of the J-box support cover (item 15) into the cavity of the support bracket and push until firmly engaged.

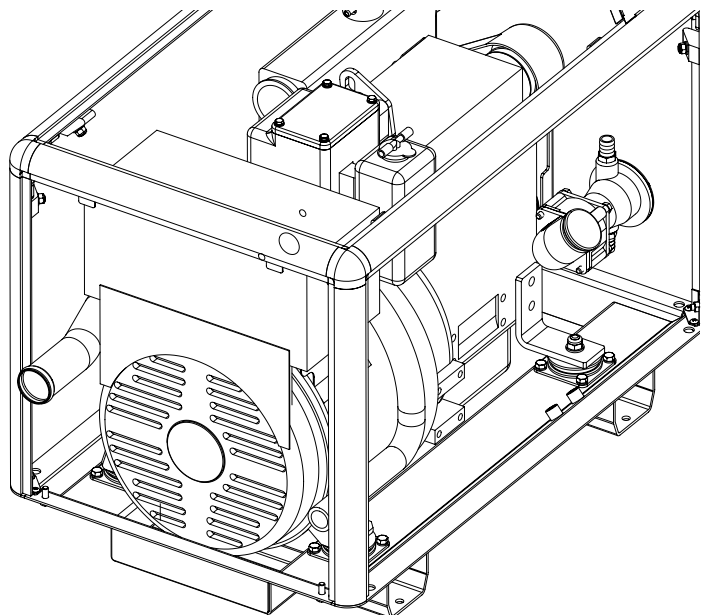
SEE FIG 6a.

When correctly installed, the support cover (item 15) should have about an inch overlap on the generator junction box rear face. The shape of the foam insert is self aligning and should hold the cover in place. The part may appear to be pushing away from the rear face of the junction box but, once the rear sound shield panel is installed, this unit will be pushed back into position.

**Fig. 6**

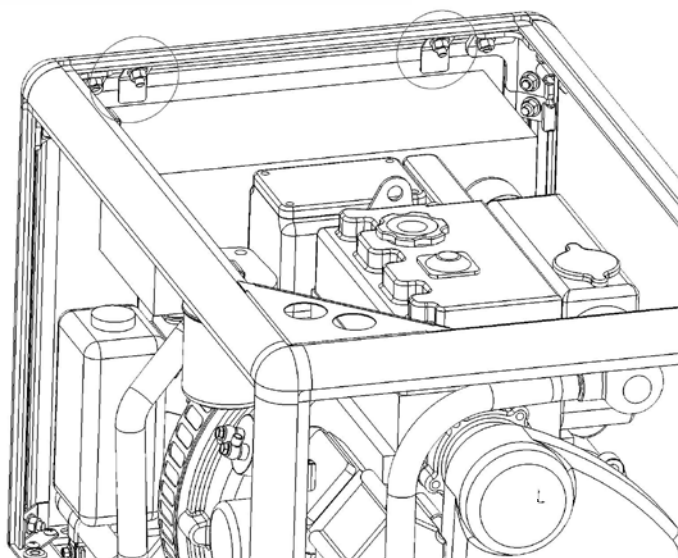
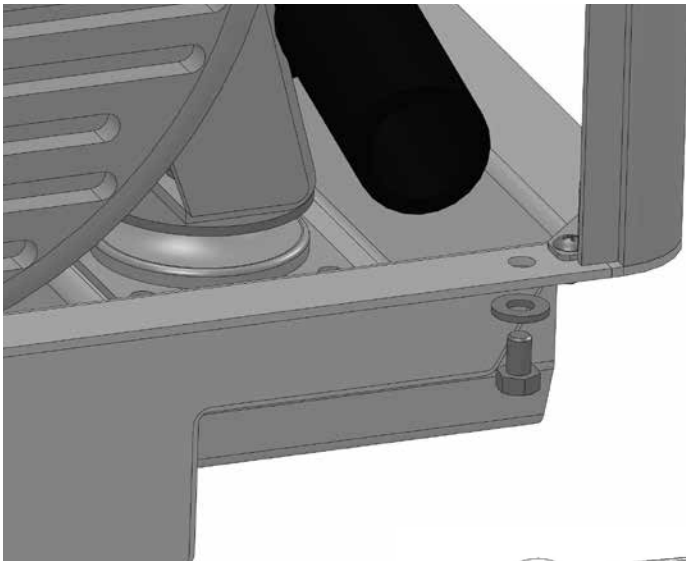


**Fig. 6a**



**7**

Next, install the rear sound shield panel (item 16) to the rear of the enclosure frame. The rear panel is designed to be stationary and is retained at the bottom by two short 5/16" bolts, and flat washers as well as at the top of the panel using a set of pre-installed retaining clips built into the top enclosure frame/top panel assembly. SEE FIGS 7 & 7a.

**Fig. 7****Fig. 7a**

The retaining clips will slide into the two rectangular slots in the top of the rear panel (item 16). With the rear panel (item 16) in place, slide these retaining clips (item 14) along the top rail until they meet the slots and can be inserted.

SEE FIG 7b.

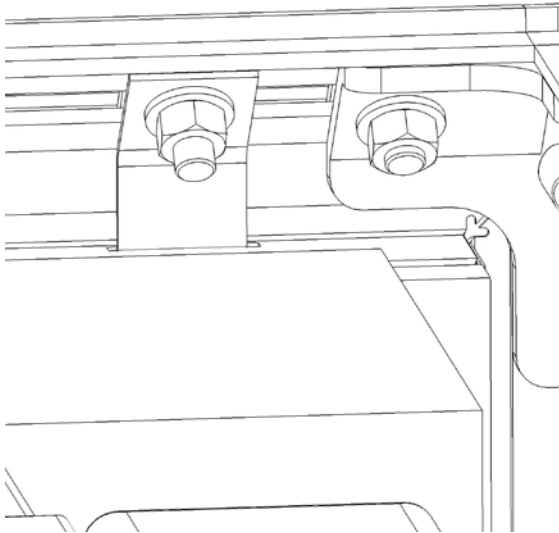
Once both are fully engaged you will be able to push the rear panel in from the bottom until flush with the back frame and base pan. Secure the rear panel with the provided 5/16" flat washer and 5/16" bolt as shown in FIGS 7 and 7c.

You may encounter some resistance as the rear panel comes into contact with the intake air snorkel hose. Note that the rear panel has a small hole in the vicinity of the intake snorkel. While holding the panel in place, guide this hose so that it is inserted within the panel hole, ensure that the hose does not go too far into the rear panel so that the hose end is blocked. (Generally this hose will install without adjustment at the retaining clamp.)

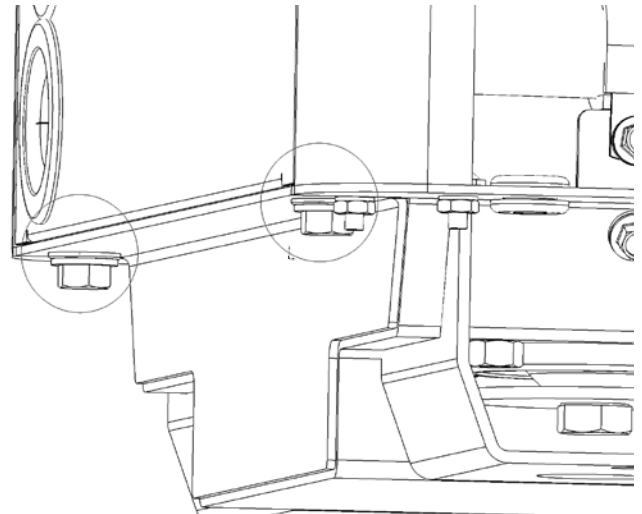
SEE FIGS 7d and 7e.



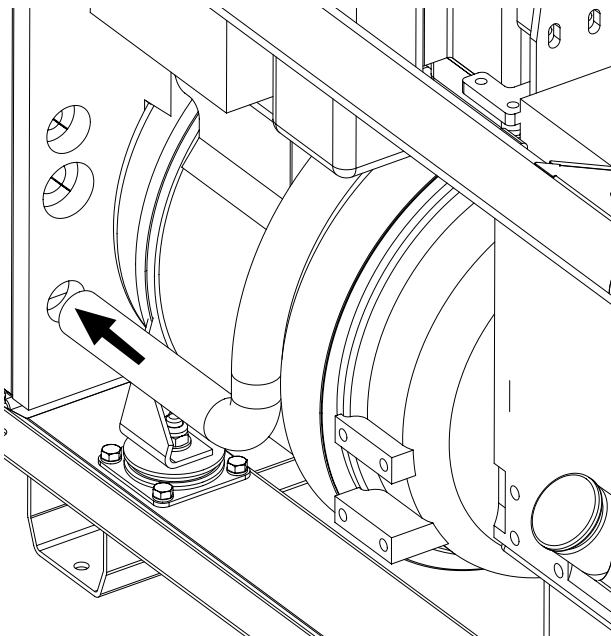
**Fig. 7b**



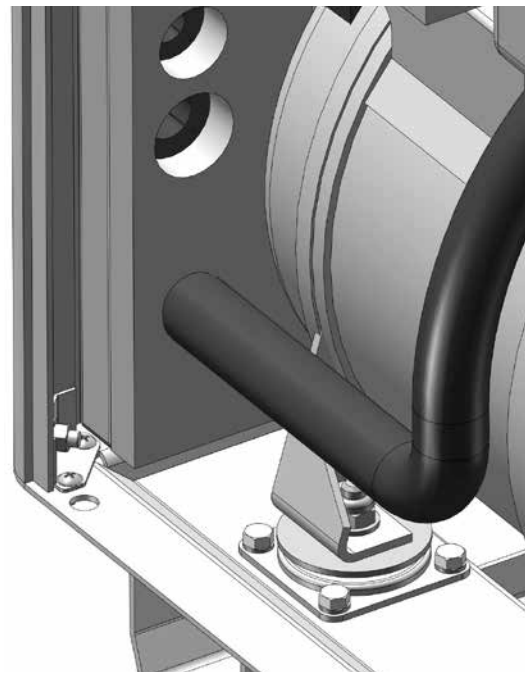
**Fig. 7c**



**Fig. 7d**

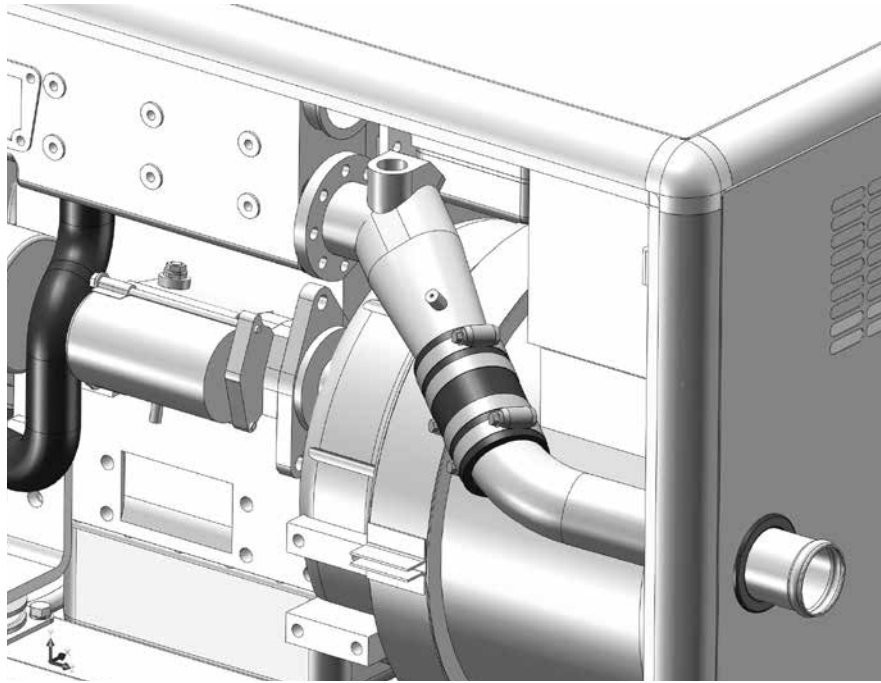


**Fig. 7e**



***When making the intake air snorkel hose connection, It is important to ensure that the hose is not kinked or bent in such a way to restrict the engine's intake air flow. This arrangement is designed to allow the hose to follow it's natural path when properly installed into the rear panel. Some adjustment is possible by loosening either bolt of the snorkel hose's supporting bracket. Be sure to retighten any loosened bolts.***

Now it is time to install the stainless steel wet exhaust tube included with this shield. The stainless tube connects to the genset's wet exhaust elbow and provides you with an external exhaust stub connection outside of the shield.



**Fig. 7f**

Following the installation of the rear panel, now take the tube (Item 23) and note its shape. The short curved end connects to the exhaust elbow, the longer with slight curve goes through the rear panel.

Apply some rubber lubricant to the inside of the short blue silicone hose part and push it on to the tube.

Next apply rubber lube to the inside of the exhaust hole grommet and with a firm twisting motion squeeze the barbed end through the grommet hole.

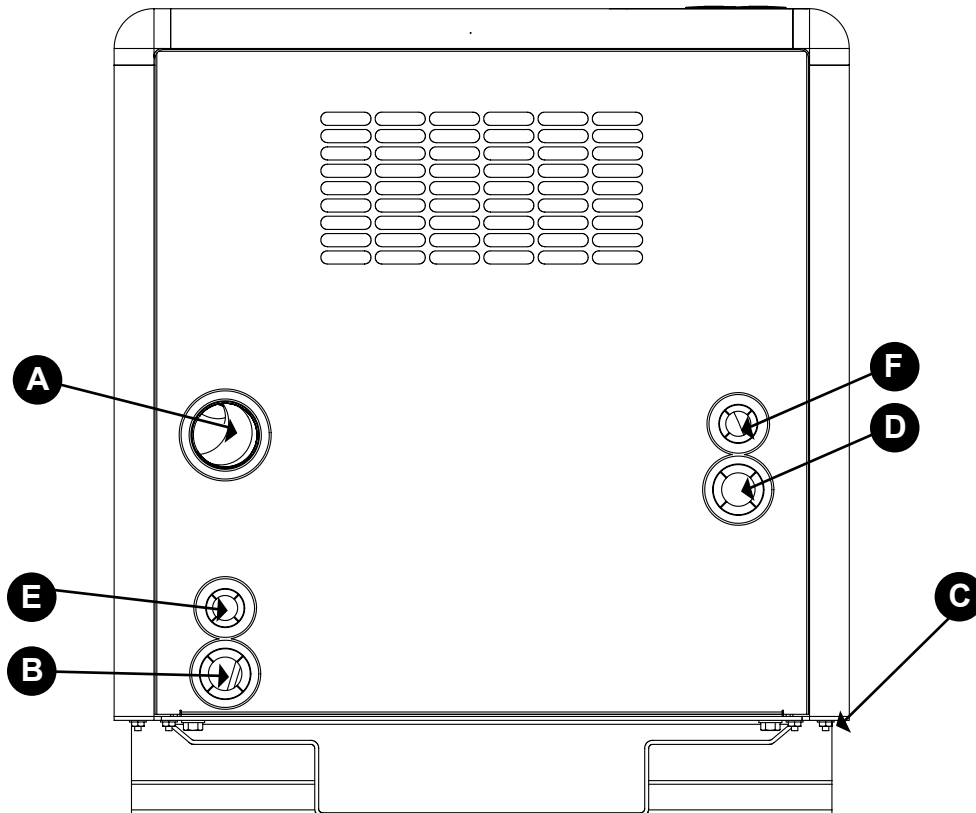
Now install the four hose clamps. Note the orientation of these clamps in the picture. Don't tighten at this time. You may want to rotate the tube to determine it's best position.

Apply some rubber lube to the inside of the available end of the blue hose and push on to the genset's exhaust elbow. Position the clamps and tighten.

When you are done, you should have results as shown in Figure 7F.

Install connections for exhaust, AC power leads, DC Control panel leads, battery and water through holes in the rear panel as shown in Figure 8 and as described below:

- a. Connect the genset exhaust outlet to the exhaust system of the vessel. Push the two inch hose on to the exhaust connection pipe protruding through the left mid-section of the rear panel.
- b. Connect the sea water pump to the vessel's water inlet. Push a 3/4" hose from the vessel's sea water strainer through the lower hole at the bottom left of the rear panel to the sea water pump inlet fitting.
- c. Connect the vessel's fuel supply and fuel return to the generator set using Coast Guard approved rubber fuel hoses. Note the fuel connection couplings on the unit's forward right side under the base pan lip. The forward 1/4" npt coupling is the fuel suction, and the aft 1/4" npt coupling is the fuel return.
- d. Connect the DC control harness to the engine harness plug. Pass the harness and plug through the hole at the mid-section of the right side of the rear panel.
- e. Connect the 12 volt battery leads to the generator set passing the two leads through the second hole above the bottom left side on the rear panel.
- f. Connect the AC output leads from the generator to the vessel's power distribution panel. Pass the two leads through the top hole on the right side of the rear panel.



**Fig. 8: Facing the Rear Panel**

**9**

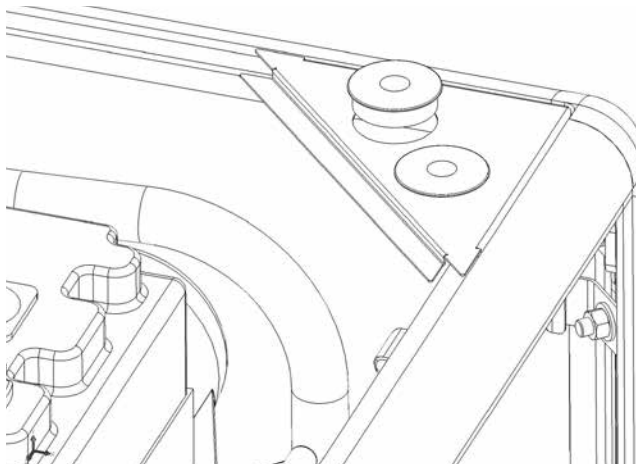
**IF YOU HAVE CHOSEN TO INSTALL A SIPHON BREAK:**

Note the pre-installed penetration plate (item 13) in the forward right corner of the top of the enclosure. Reference the plumbing diagram in the mounting and exhaust sections of the IM1000 installation manual.

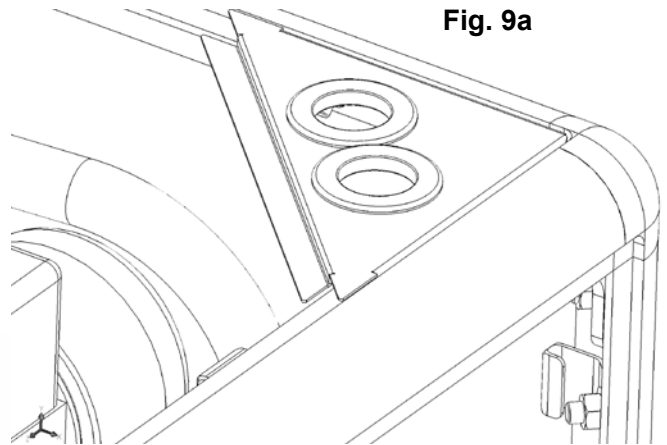
Remove the white plastic hole plugs by pushing them out from the inside and replace with the two rubber grommets (item 21) provided. Next install the piece of sound foam (Item 22) to the underside of the penetration plate. Before removing the back paper, position the foam piece underneath the plate and dry fit by aligning the two holes in the respective parts. Then remove the paper backing and press firmly to adhere.

SEE FIGS 9, 9a and 9b.

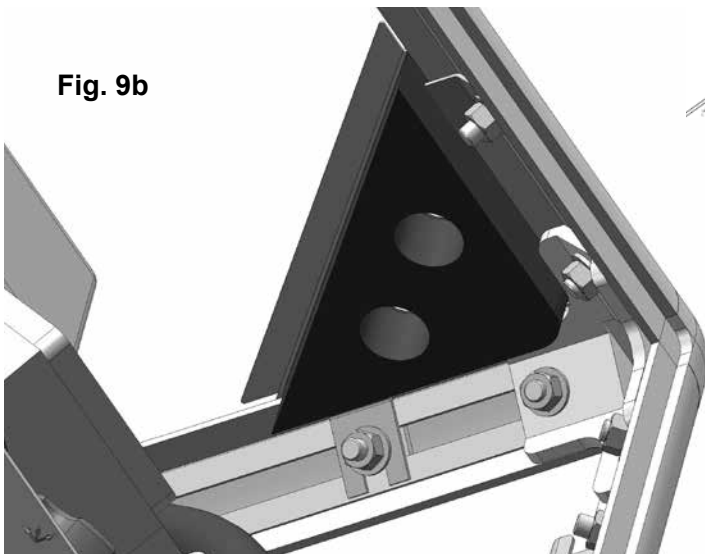
**Fig. 9**



**Fig. 9a**



**Fig. 9b**



**CAUTION: GENERATOR SETS WITH WET EXHAUST THAT ARE INSTALLED NEAR OR BELOW THE VESSEL'S WATER LINE MUST USE A SIPHON BREAK TO PREVENT BACKFLOW OR WATER INTO THE ENGINE. THIS BACKFLOW CAN RUIN AN ENGINE AND POSSIBLY SINK THE VESSEL.** The penetration plate (item 13) facilitates the siphon break installation as follows:

- a. Disconnect the hose from the seawater pump output and from the rubber elbow on the expansion tank. Install two lengths of 3/4" hose. The hoses must be of adequate length to allow mounting of a siphon break, a minimum of 12 inches above the vessel's loaded water line.
- b. Pass the seawater pump output hose through the hole in the penetration plate closest to the front of the shield. The hose from the expansion tank must go through the hole in the penetration plate closest to the side of the shield.
- c. For more information, see the "Exhaust" section of the IM1000 Installation Manual included with the generator set.

**10**

Start the generator set and run under load to check for leaks of fuel, water or exhaust gas.

**11**

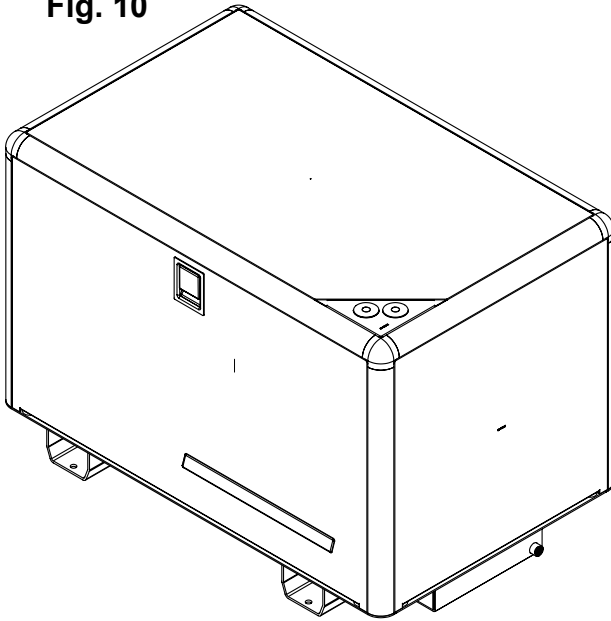
As you install the panels, observe that there should be a minimum clearance of approximately 1/32" around the panel parameter (except at the bottom of the side and front panels.) You may adjust for this by loosening any number of corner bolting assemblies or toe brackets until fit is satisfactory. Tighten all connections when done.

To secure the left side panel and front panel retaining blocks, install the left panel in place, taking note of the rectangular slots on each side of the panel. Slide the retaining blocks (item 8) up the vertical extrusion legs until the blocks are captured by these slots. Proceed to tighten the bolting assembly while holding the block in position. Then do similarly on the front panel. Do ensure that the block does not rotate upon tightening as it may affect engagement.

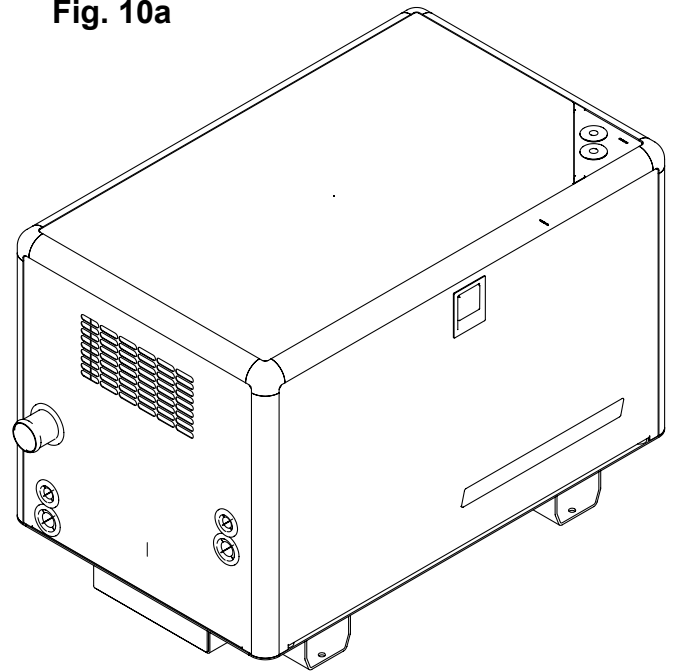
Northern Lights sound shield removable panels now feature a nylon block retaining system that omits all but one panel latch. Install the left side panel (item 17) and the front panel (item 18) by aligning the panel bottom pins to the base pan flange grommets and push until engaged. The panels are easiest to install by pushing the panel in near the location of the retaining block. The top panel (item 12) is installed by first placing the opposite side down on the enclosure frame flange and then pushing down the near side. Install the right panel (item 19) by striking firmly with your hand to engage the paddle latch.

SEE FIG 10 and 10a.

**Fig. 10**



**Fig. 10a**

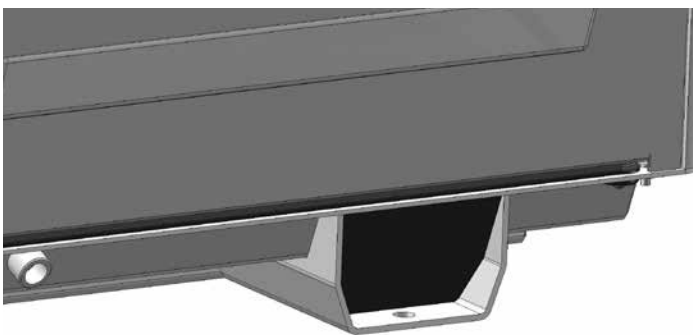


To access the top panel, remove the latched right side (service) panel. Reach in with your fingers and push up on the panel from the inside. The front and left side panels remove similarly, by pushing out from the inside.

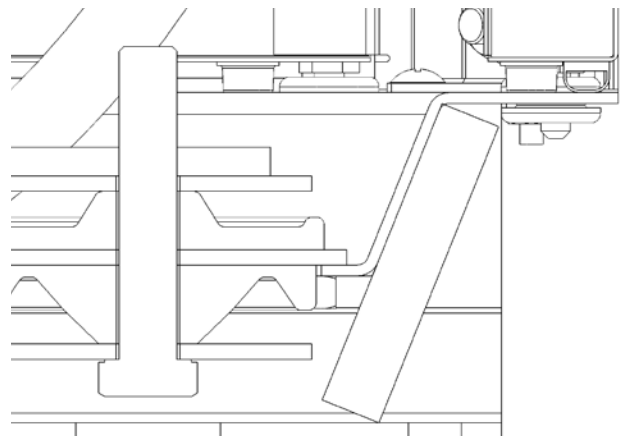
**12**

Finally, note the generator set base frame pan has four mounting feet “pockets.” Take foam block (item 20) but do not remove the backing paper at this time, and insert it into each mounting foot pocket as shown in FIG 11. Note that the upper portion of the block lays against the angled surface of the base pan. The foam part will compress slightly when inside the foot pocket as it provides a noise seal from the engine mounts. After you have noted how the foam block is situated, withdraw it and remove only the top half of the backing paper to expose the adhesive layer. Then pinching the block at the top outer corner, reinstall it and press firmly against the contact area to ensure good adhesion. SEE FIG 11a.

**Fig. 11**



**Fig. 11a**





# M843NW3 SOUND SHIELD PACKING LIST

ITEM#	DESCRIPTION	NLI PART #	QTY	NOTES:	PACKED
	Enclosure frame top, pre-assembled: (consists of the following parts and assemblies)				<input type="checkbox"/>
9	Extrusion, horizontal, sides	05-73129	2	assembled	
10	Extrusion, ends	05-73128	2	assembled	
11	Corner casting	05-70001	4	assembled	
7	Bolting assembly, long	00-72003	4	installed	
6	Bolting assembly, short	00-75714	12	installed	
	Penetration panel retainer bracket (inc. w/ #13 assy)	23-78006	2	installed	
13	Penetration panel assembly	05-78022	1	installed	
14	Rear panel retainer bracket	23-78003	2	installed	
8	Panel retainer block, single nosed	23-78016	4	installed	
12	Top panel assembly	05-73136	1	assembled	
<hr/>					
	Sound shield panels:				
15	Junction Box Support Bracket Cover Assy	05-78636	1		<input type="checkbox"/>
17	Left side panel assembly	05-73132	1	assembled	<input type="checkbox"/>
19	Right side panel assembly	05-73131	1	assembled	<input type="checkbox"/>
18	Front panel assembly	05-73134	1	assembled	<input type="checkbox"/>
14	Rear panel assembly	05-73133	1	assembled	<input type="checkbox"/>
<hr/>					
	Hardware box: (consists of the following parts)				
1	Toe bracket	23-78007	4	loose (bagged)	<input type="checkbox"/>
7	Bolting assembly, long (hardware loose)	05-72003	4	loose (bagged)	<input type="checkbox"/>
6	Bolting assembly, short (hardware loose)	00-75714	8	loose (bagged)	<input type="checkbox"/>
8	Panel retainer block, single nosed	23-78016	4	loose (bagged)	<input type="checkbox"/>
2	#10-32 machine screw x 1/2" long s/s	12-00000	8	loose (bagged)	<input type="checkbox"/>
4	#10-32 nylock hex nut stainless steel	14-00032	8	loose (bagged)	<input type="checkbox"/>
5	Extrusion, vertical	05-73127	4	loose	<input type="checkbox"/>
3	#10 flatwasher USS stainless steel	15-70002	8	loose (bagged)	<input type="checkbox"/>
21	Grommet 1-1/8 ID x 1-7/8 OD	00-70083	2	loose (bagged)	<input type="checkbox"/>
	5/16-18 hex head capscrew, stainless steel	12-09203	2	loose (bagged)	<input type="checkbox"/>
	5/16 flatwasher, USS stainless steel	15-11000	2	loose (bagged)	<input type="checkbox"/>
23	Kit Wet Exhaust Outlet Tube (Consists of)	27-33110	1		<input type="checkbox"/>
	Hose 2" ID x 3-1/2" 3 Ply Silicone	18-21018	1		<input type="checkbox"/>
	Extended band clamps	19-01032	4		<input type="checkbox"/>
	Exhaust outlet tube S/S	27-33108	1		<input type="checkbox"/>
<hr/>					
20	Sound foam, base pan mounting foot pocket	55-73138	4	loose (bagged)	<input type="checkbox"/>
22	Sound foam, penetration plate option	55-78066	1	loose (bagged)	<input type="checkbox"/>

**Packed By:** \_\_\_\_\_

**Date:** \_\_\_\_\_



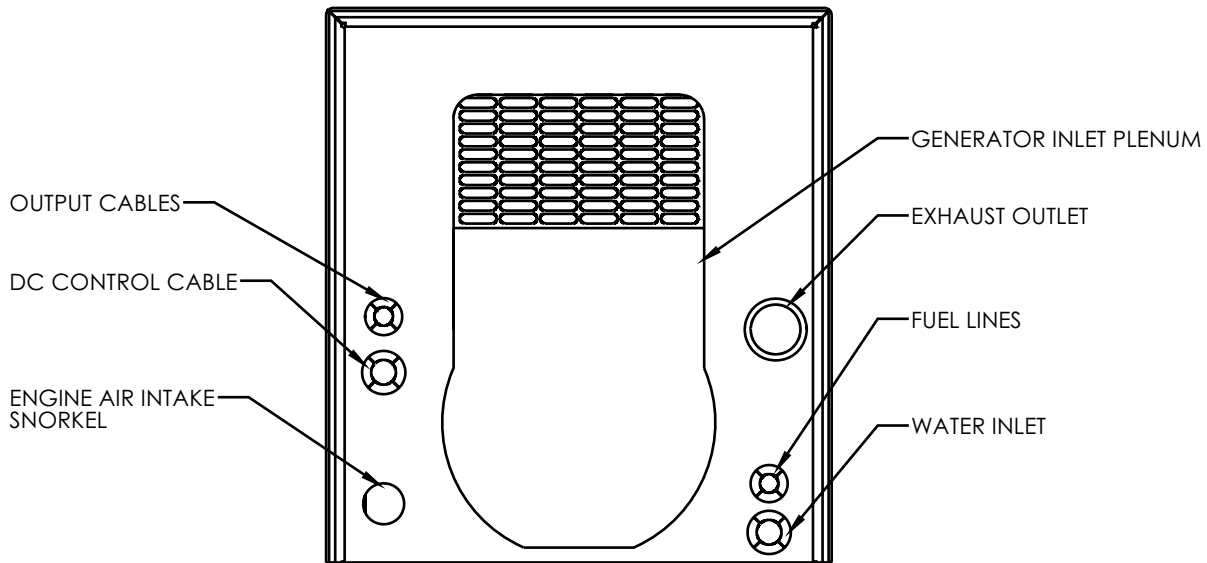
# A NORTHERN LIGHTS SOUND ENCLOSURE ASSEMBLY ADDENDUM PAPER

This affects the following Sound Enclosure Assembly Instructions:

- M673L3 05-78025
- M773L3 05-78625
- M843NW3 05-73120
- M844W/LW3 05-70020
- M864W3 05-78725
- M944W3 05-01205

SHOWN BELOW IS THE INTERIOR VIEW OF A TYPICAL SOUND SHIELD REAR PANEL. APPEARANCE MAY VARY DEPENDING UPON GENSET MODEL.

**REMOVE FOAM PLUGS AT LOCATIONS AS SHOWN BELOW.**



**NOTE: SOME LOCATIONS CONSIST OF TWO LAYERS OF SOUND FOAM. TWO PLUGS MAY BE PRESENT AND MUST BE REMOVED BEFORE PANEL INSTALLATION.**

Completed By: \_\_\_\_\_ Date: \_\_\_\_\_



**NORTHERN LIGHTS**

Northern Lights, Inc. • 4420 14th Ave. NW., • Seattle WA 98107  
 Tel: 206-789-3880 • 1-800-762-0165 • Fax: 206-782-5455  
 Information and dimensions subject to change without notice.  
 Northern Lights and Lugger are registered trademarks of Northern Lights, Inc.  
 © 2015 All rights reserved. Litho USA. 5/16