

OPERATOR'S MANUAL

06170

For Model
6170

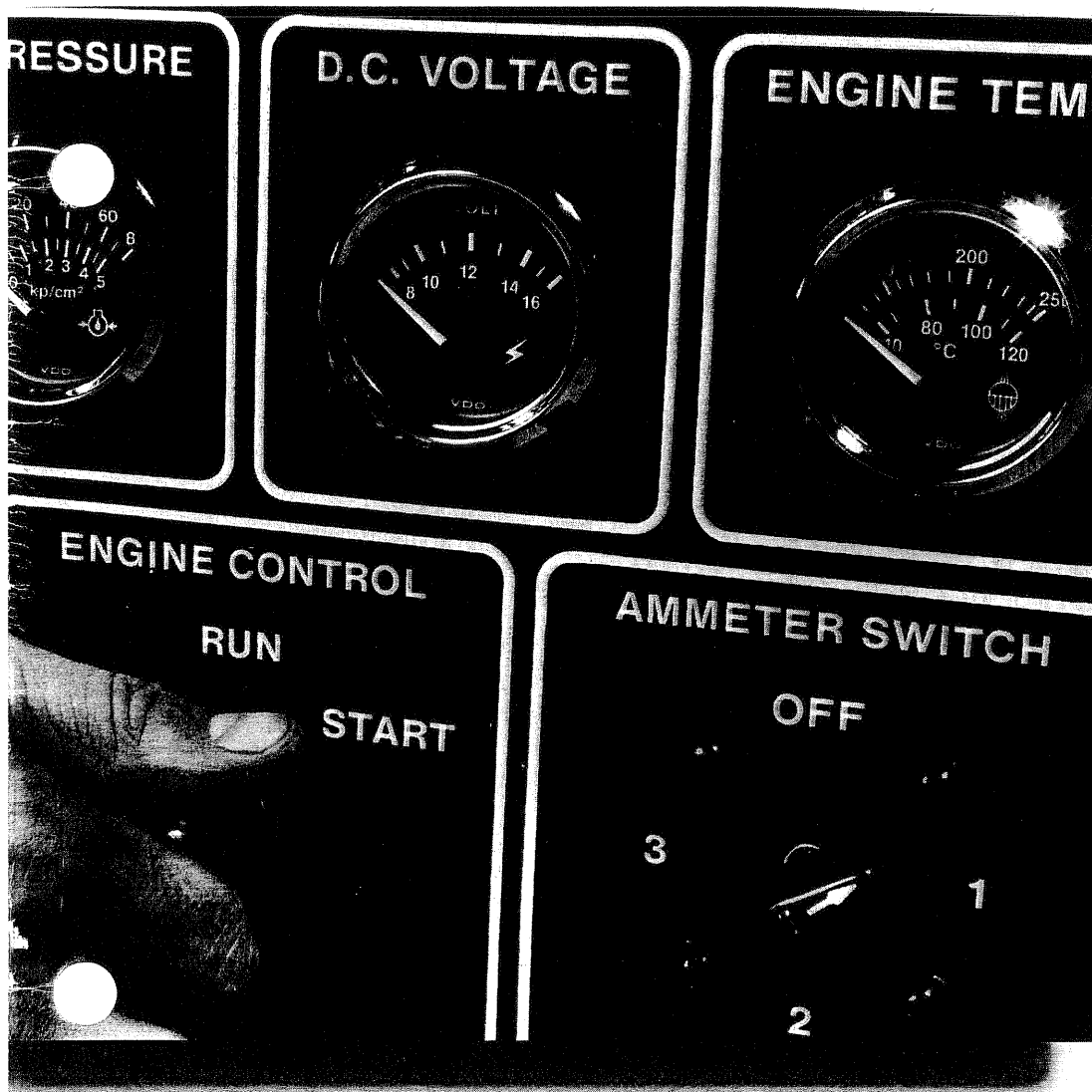

NORTHERN LIGHTS

— CALIFORNIA —
Proposition 65 Warning:

*Diesel engine exhaust and some of its constituents
are known to the State of California to cause
cancer, birth defects, and other reproductive harm.*



Northern Lights

4420 14th Avenue N.W.

P.O. Box 70543

Seattle, WA 98107

Tel: (206) 789-3880

Fax: (206) 782-5455

Copyright ©2003 Alaska Diesel Electric, Inc.
All rights reserved. Northern Lights™, and
the Northern Lights logo are trademarks of
Alaska Diesel Electric, Inc.

Printed in U.S.A.
PART NO.: 06170 03/03

O6170

OPERATOR'S MANUAL FOR MODEL 6170

*Read this operator's manual thoroughly before starting to operate your equipment.
This manual contains information you will need to run and service your new unit.*

TABLE OF CONTENTS

Introduction	2	Servicing (cont.)	
Unit Identification		Turbocharger	17
Model Designation	2	Cooling System Requirements	18 - 20
Serial Numbers	2	Checking Coolant Level	20
Warranty	3	Flushing the Cooling System	20 - 21
Safety Rules	3	Heat Exchanger Cleaning	21
Component Locations		Cleaning Gear Oil Coolers	21
Lugger Propulsion Unit	4	Zinc Electrodes	21
Marine Generator Set	5	Raw Water Pump	21
Panels		Coolant Filter	21
Instrument Panels	6	Electrical System - General	22
Series 3 & 4 Control Panels	7	Booster Batteries	22
Operating Procedures		Battery Care	22
Before Starting	8	Winterizing - Out-of-Service	22
Shutdown Procedures	9	Propeller Sizing Chart	23
Break-in Period	9	Data Sheets	
Servicing Schedule Chart	10	Lugger Propulsion	24
Service Record	11	Northern Lights Marine Generator Set	25
Servicing		Troubleshooting	
Lubrication - General	12	Electrical	26
Oil Changes	12	Engine	27
Changing Oil Filter	12 - 13	DC Wiring Diagrams	
Air Filter	13	24 Volt Lugger Engine	28
V-Belts	13	24 Volt Marine Generator Set	29
Valve Clearances	13	24 Volt Industrial Generator Set	30
Fuels - General	14	Onboard Spare Parts	31
Fuel Filters	14		
Bleeding the Fuel System	14		
Injectors	14 - 15		
Injection Pump	15 - 17		

Proprietary Information

This publication is the property of Alaska Diesel Electric, Inc. It may not be reproduced in whole or part without the written permission of Alaska Diesel Electric, Inc. ©Alaska Diesel Electric, Inc. All rights reserved. Litho USA. Publication number O6170 03/03

INTRODUCTION

Servicing of marine engines and generator sets presents unique problems. In many cases boats cannot be moved to a repair facility. Marine engines cannot be compared to the servicing of automobiles, trucks or even farm equipment. Failures often occur in remote areas far from competent assistance. Marine engines are taxed far more severely than auto or truck engines; therefore, maintenance schedules must be adhered to more strictly.

Failures usually begin with minor problems that become amplified when not corrected during routine maintenance.

As owner-operator, it is your obligation to learn about your equipment and its proper maintenance. This manual is not a comprehensive technical service manual. Nor will it make the reader into an expert mechanic. Its aim is to aid you in maintaining and servicing your equipment properly.

UNIT IDENTIFICATION

MODEL NUMBER

Model numbers give unit's application, block model, aspiration and RPM:

L - M - NL

L - Lugger marine propulsion engine M - Northern Lights marine generator set NL - Northern Lights industrial generator set

6170

Model number of Komatsu engine block 6 cylinder, 170 mm bore
--

A

A - Aftercooled (turbo)

Examples:

L6170A	Lugger turbocharged-aftercooled marine propulsion engine. Komatsu 6170 block.
---------------	---

M6170A	Northern Lights turbocharged 1800 or 1500 RPM marine diesel generator set. Komatsu 6170 block.
---------------	--

SERIAL NUMBERS

When referencing Alaska Diesel Electric equipment by serial number, refer only to the number stamped on the Lugger or Northern Lights serial number plate.

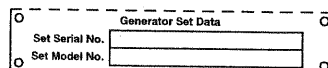
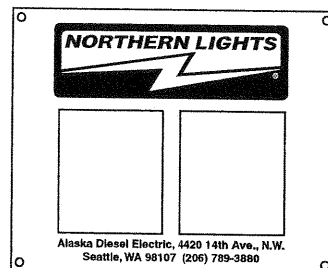
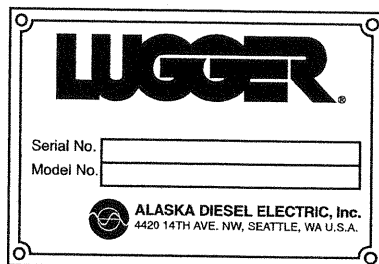
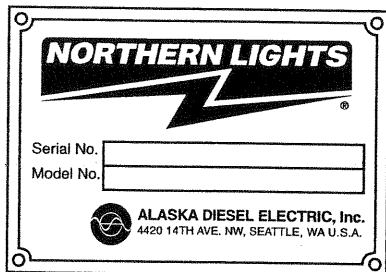

WARRANTY

A warranty registration certificate is supplied with your set. It entitles the original purchaser of this equipment to a warranty covering material or assembly faults. The extent of coverage is described in the Limited Warranty Statement. We recommend that you study the statement carefully.

If the warranty is to apply, the servicing instructions outlined in this manual must be followed. If further information is needed, please contact an authorized dealer or the factory.

SAFETY RULES



Accident reports show that careless use of engines cause a high percentage of accidents. You can avoid accidents by observing these safety rules. Study these rules carefully and enforce them on the job.

- Never leave engine without proper security.
- Turn the coolant tank cap slowly to relieve pressure before removing. Add coolant only when the engine is idling or stopped.
- Mount fire extinguisher near engine.
- Always disconnect the battery ground strap before making adjustments.
- Operate engines in properly ventilated areas.
- Keep trash and other objects away from engine.
- Escaping fluids under pressure can penetrate your skin. Use a piece of cardboard or wood, not your hands, to search for leaks.
- Avoid wearing loose clothing without a belt when working around engines.
- Do not oil or grease engine while it is running.
- Use caution in handling fuel. Never refuel a hot or running engine. Do not smoke while filling fuel tank or servicing fuel system.
- Keep your hands, feet, hair and clothing away from power-driven parts.
- Check for any loose electrical connections or faulty wiring.
- Engines should be operated only by knowledgeable, qualified personnel.
- Walk completely around engine to make sure that everything is clear before starting the engine.
- Do not operate an engine that isn't in proper working order. If an unsafe operating condition is noted, tag the engine so others will also know about it.
- Provide first aid kits.

COMPONENT LOCATIONS

Lugger Propulsion L6170A

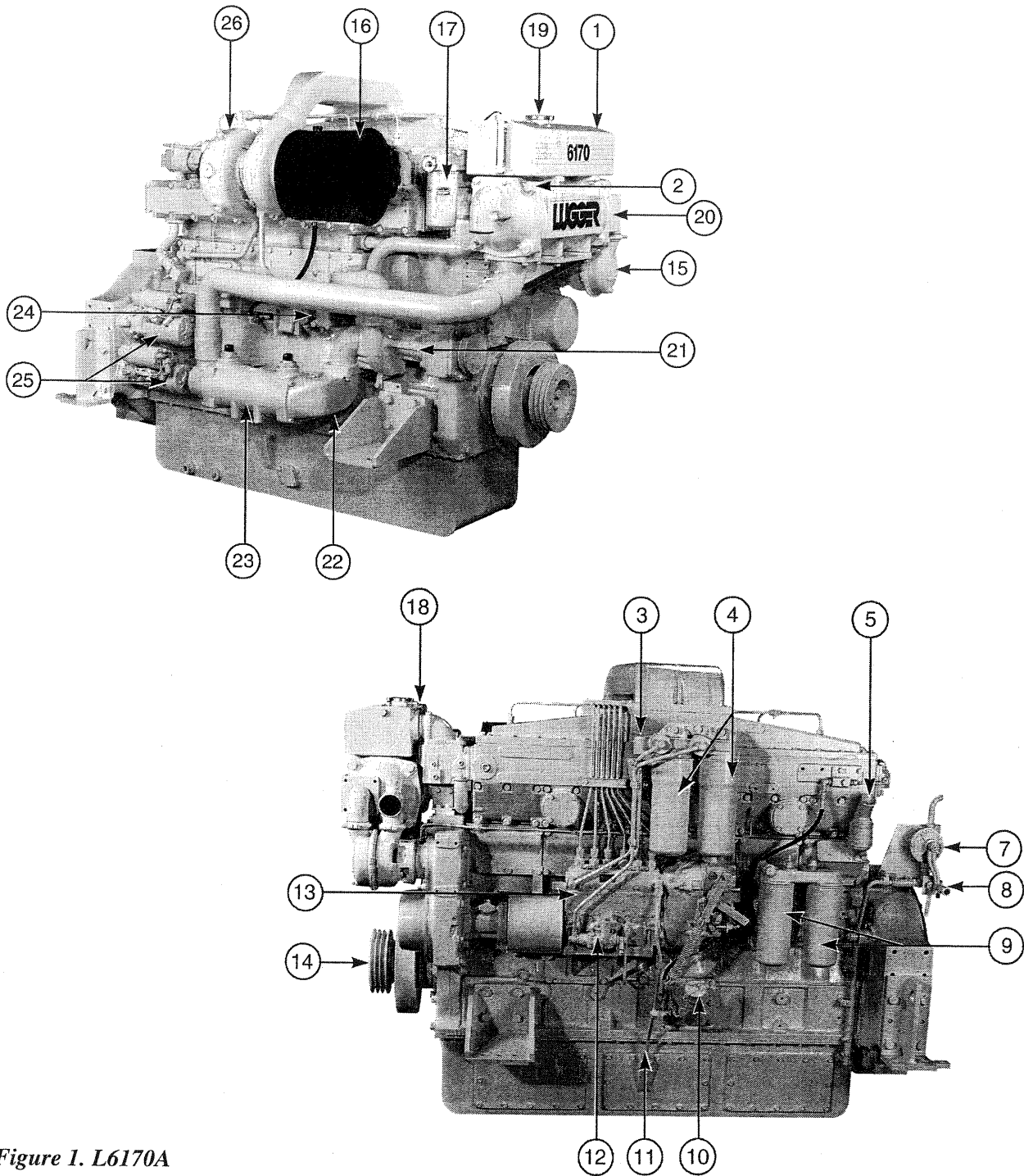

Figure 1. L6170A

- | | | | |
|--------------------------------|--------------------------------|------------------------------|------------------------------|
| 1. Expansion Tank | 9. Oil Filters (2) | 15. Raw Water Pump | 20. Heat Exchanger |
| 2. Zinc (2) | 10. Oil Fill | 16. Airsep Air Filter (opt.) | 21. Jacket Water Pump |
| 3. Fuel System Bleed Plug | 11. Lube oil dipstick | Foam Air Filter Standard | 22. Gear Oil Cooler & Heat |
| 4. Fuel Filters (2) | 12. Fuel Priming Pump (Manual) | 17. Coolant Filter | Exchanger Jacket water drain |
| 5. Crankcase Vent Outlet | 13. Injection Pump | 18. Cooling System Vent | 23. Gear Oil Cooler |
| 7. Lube Oil Change Pump (opt.) | 14. Crankshaft Pulley (Front | (K.C. only) | 24. Jacket water block drain |
| 8. Pump Valve | PTO optional) | 19. Coolant Filler Cap | 25. Starters (2) |
| | | | 26. Turbocharger |

COMPONENT LOCATIONS

M6170A Northern Lights Marine Generator Set

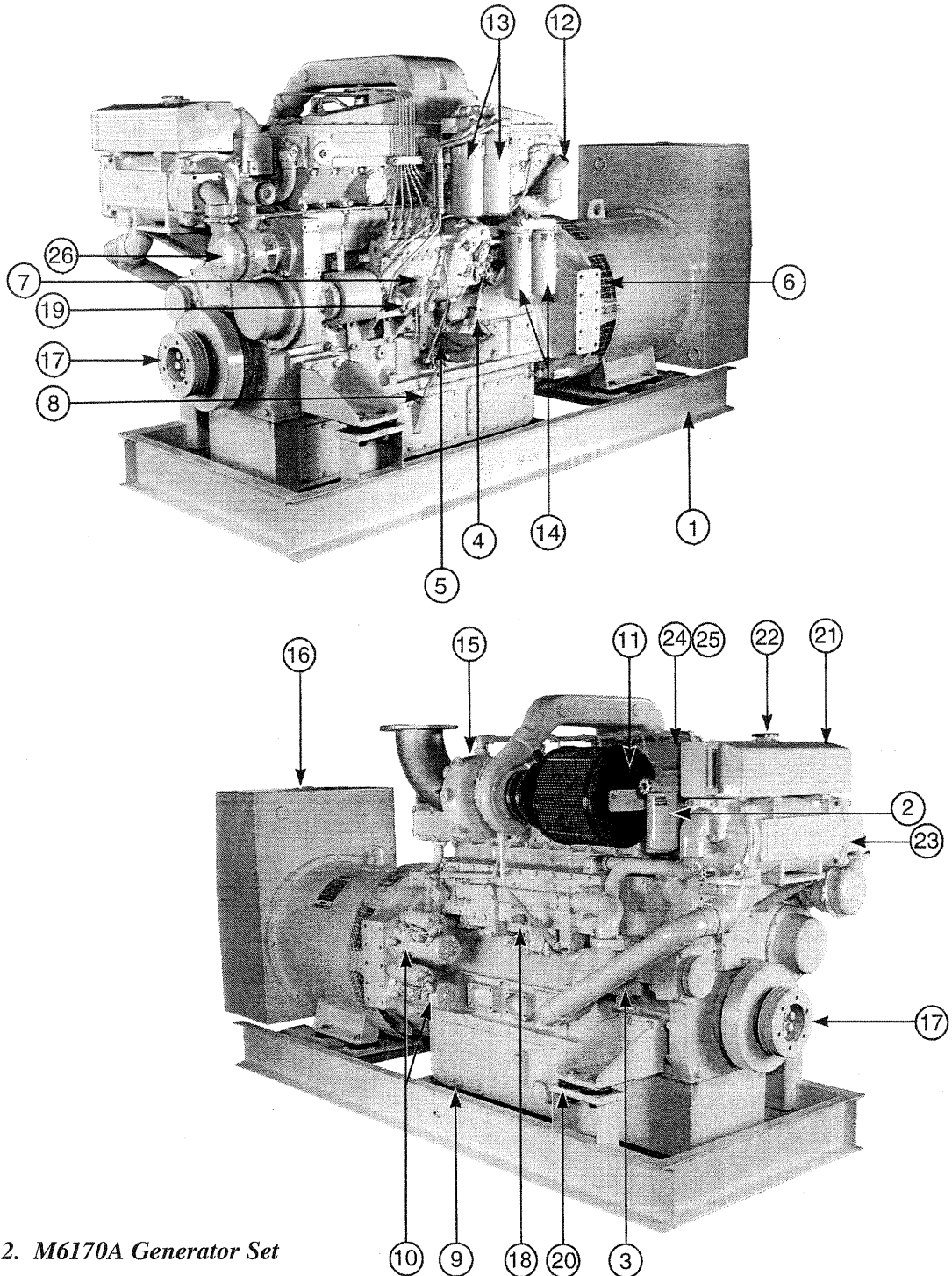

Figure 2. M6170A Generator Set

- | | | | |
|---------------------|---|---------------------------|---------------------------|
| 1. Base Frame | 7. Fuel Feed Pump and Manual Priming Pump | 13. Secondary Fuel Filter | 20. Anti-vibration mounts |
| 2. Coolant Filter | 8. Lube Oil Dipstick | 14. Lube oil filter | 21. Expansion tank |
| 3. Fresh Water Pump | 9. Lube Oil Drain | 15. Turbocharger | 22. Coolant system fill |
| 4. Stop Solenoid | 10. Starter (2) | 16. Generator "J" box | 23. Heat exchanger |
| 5. Lube Oil Fill | 11. Air Cleaner | 17. Crankshaft Pulley | 24. Rocker arm cover |
| 6. Generator Fan | 12. Crankcase Vent | 18. Block drain | 25. Cylinder head |
| | | 19. Fuel injection pump | 26. Raw water pump |

INSTRUMENT PANEL

1. OIL PRESSURE GAUGE:

The oil pressure gauge shows the oil pressure in the engine lubricating system. If the oil pressure drops BELOW 15 PSI at a speed higher than idling, stop engine immediately and investigate.

2. WATER TEMPERATURE GAUGE:

This gauge shows the temperature of the cooling water. If a temperature of over 205° is indicated, stop engine and investigate immediately.

3. TACHOMETER:

The tachometer shows the engine speed in revolutions per minute (RPM). Numbers are multiples of 100.

4. VOLTMETER:

When the engine is stopped, the voltmeter will indicate the condition of the battery. When the engine is running, it shows the alternator voltage output.

5. HOUR METER:

The hour meter keeps track of the accumulated length of the engine's operating time.

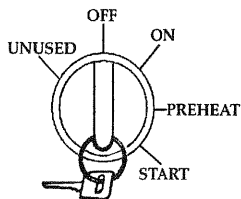

6. KEY SWITCH:

The key must be kept in "ON" position while the engine is running.

7. STOP BUTTON:

Hold down until engine is completely stopped.

8. INSTRUMENT LIGHTING DIMMER :

Adjust instrument panel lights. (On some panels this is an on/off switch and not a dimmer.)

9. WARNING LIGHTS:

- a. Light comes on when oil pressure is too low.
- b. Light comes on when engine is too hot.

10. ALARM HORN:

Will sound in case of overheating or low oil pressure. Stop engine and investigate. Remember horn will sound when key is in "ON" position with engine stopped because there is no oil pressure.

11. START BUTTON:

Will start engine only if key on main panel is in "ON" position.

12. EXHAUST TEMPERATURE:

Maximum temperature: 975°F (510°C).

13. TURBO BOOST GAUGE

14. GEAR PRESSURE GAUGE:

See Gear Manual for operating range.

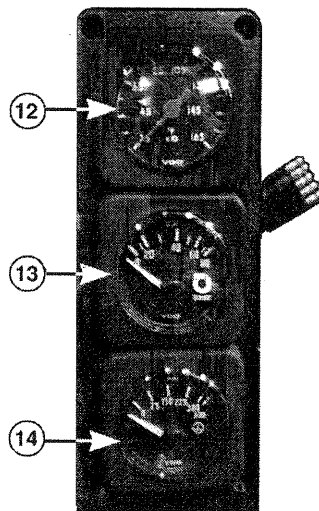

Figure 5 -
Auxilliary
Panel

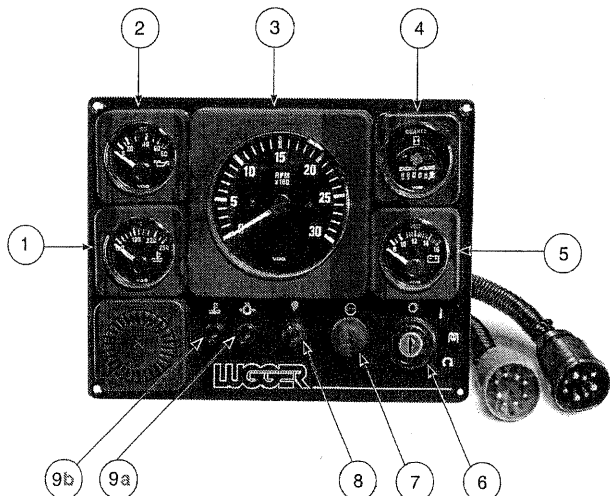

Figure 3 - Main Panel

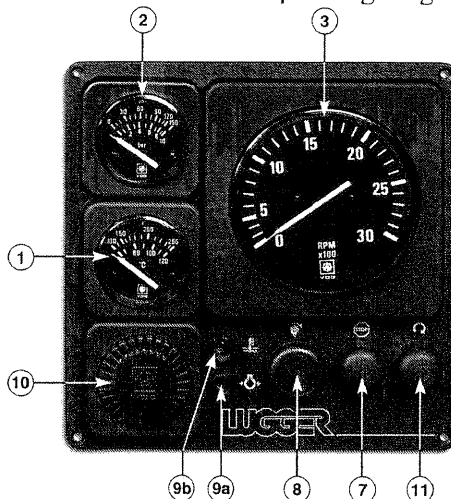

Figure 4 - Flybridge Panel

CONTROL PANELS

SERIES 3 GENERATOR CONTROL PANEL

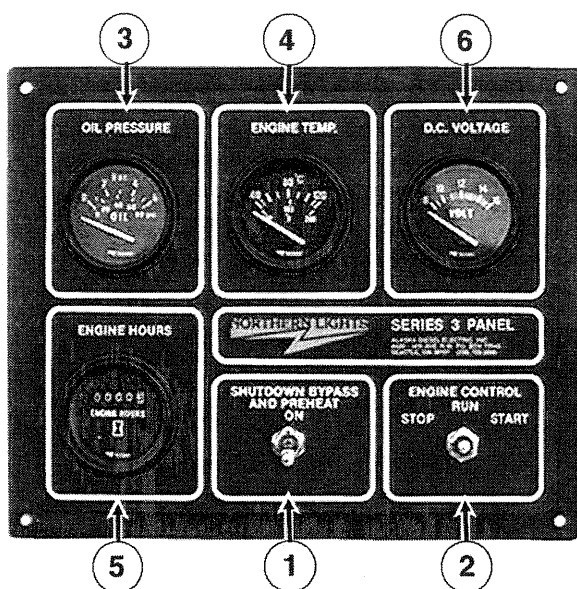

Figure 6

SERIES 4 GENERATOR CONTROL PANEL

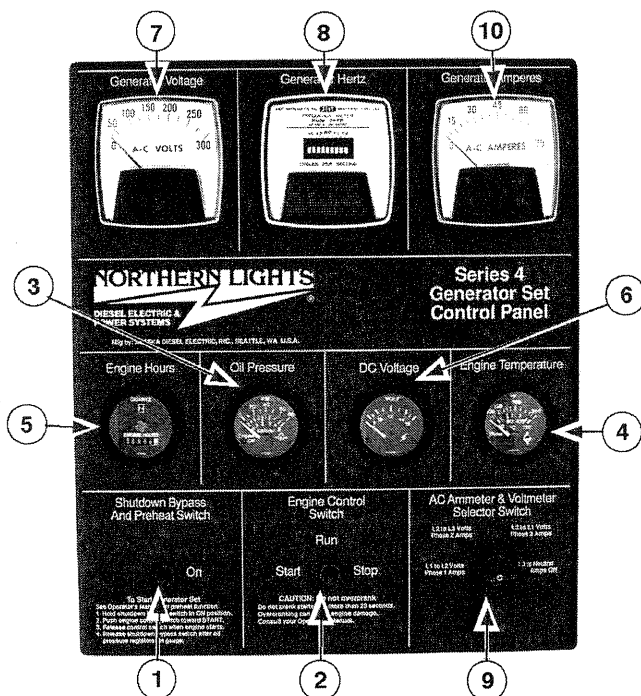

Figure 7

1. SHUTDOWN BYPASS PREHEAT SWITCH:

Two functions are built into this switch: The preheating of the engine, and bypassing of the engine safety shutdown circuit, enabling a quicker start. Hold switch in up position 10-20 seconds before starting engine, and continue holding in up position while starting engine. Holding the switches on too long can burn out the heater elements.

2. ENGINE CONTROL SWITCH:

To start the engine, hold switch in start position until the engine is running. After the engine starts, release switch and it will return to the center position. To stop engine, move switch to stop position and release.

3. OIL PRESSURE GAUGE:

The oil pressure gauge shows the oil pressure in the engine lubricating system.

4. WATER TEMPERATURE GAUGE:

Registers temperature of cooling water.

5. HOUR METER:

Keeps track of engine running time.

6. D.C. VOLTMETER:

When the engine is stopped, the voltmeter indicates the condition of the battery. When the engine is running, the voltmeter indicates the voltage output of the alternator.

For Series 4 Control Panels Only:

7. A.C. VOLTMETER:

Shows the generator output voltage.

8. FREQUENCY METER (HERTZ):

The frequency meter indicates the frequency of alternating current: 1200 or 1800 RPM (60 Hz), 1500 RPM (50 Hz).

9. AMMETER SELECTOR SWITCH:

Used to check each phase for load condition. You must *always* leave this switch in the "ON" position while the unit is running.

10. A.C. AMMETER

Shows the generator load on each phase. The phase is selected on the Ammeter Selector Switch (switch #9 above).

OPERATING PROCEDURES

BEFORE STARTING

1. Check the water level by removing the pressure cap from the expansion tank. In order to give the cooling water an opportunity to expand, the level should be about 1 3/4 in. (4-5 cm) below the filler cap sealing surface when the engine is cold. When filling with coolant, all the venting cocks should be opened to ensure that no air pockets form in the cooling system.



CAUTION: Use protective clothing and open the filler cap carefully when the engine is warm to prevent burns.

2. Check the oil level in the crankcase with the dipstick. The oil level must be in the waffled area between the "L" and "H." Never allow the level to go below the "L." Always add the same viscosity of oil as is already in the crankcase.
3. Check the fuel tank level and open any fuel valves.
4. Propulsion Only: Check the oil level in the reverse gear. Methods may vary from gear to gear. See your Gear Owner's Manual.
5. Close the sea cock, check and clean the strainer and reopen the sea cock.
6. Place the battery switch in the ON position.

NOTE: The battery switch must always be kept ON while the engine is running. If the switch is turned OFF while the engine is running, the battery charging regulator could be damaged.

GENERATOR

Starting

1. While holding the Shutdown Bypass/ Pre-heat switch in ON position, push the Engine Control switch to START position. As soon as the engine starts, release both switches. Do not crank the starter for more than 20 seconds. If the engine fails to start the first time be sure the starter has stopped before re-engaging.
2. Cold Weather: Hold Shutdown Bypass/ Pre-heat switch in the ON position for 30 seconds before starting. This will warm the air heater elements and will ease starting. This is not necessary if engine is warm. A longer pre-heat time may be required in extremely cold weather.

Operating

1. **Check Gauges Often:** Oil pressure must be above 29 PSI. The DC voltmeter should read between 13 and 14 volts (26-28 volts, 24 volt systems) at 60°F (16°C) ambient temperature. Water temperature gauge must be below 205°F (96°C). Check AC voltage and frequency meters. If gauges deviate from normal levels, shut down the set and investigate.
2. Let the unit run unloaded for a three to five minute warm-up period.
3. Do not add full electrical load until the engine has reached normal operating temperature.

PROPULSION ENGINE

Starting

1. Put the gear control in the neutral position.
2. Move the throttle control to the full speed position and return back to idle.
3. Turn the key switch to the first position. Check the voltage meter to see the condition of the batteries. For starting, the voltmeter should not read below 12 volts (24 volts for 24 volt systems).
4. In cold weather, turn the key to the preheat position and hold there for 20-30 seconds.
5. Turn the key to the starting position and as soon as the engine starts, release the key. Move the throttle up until the engine is running at approximately 1000 RPM.
6. **Do not crank the starter for more than 20 seconds consecutively.** If the engine fails to start with the first attempt, be sure that the starter has stopped completely before re-engaging.

NOTE: Never race a cold engine. Operate at 1000 RPM for a 3-5 minute warm-up period.

Operating

1. Check oil pressure as soon as the engine has started. Oil pressure should be above 29 PSI. The engine must never be run if the oil pressure is below 15 PSI.
2. Check the voltmeter. It should read 13 to 14 volts (26-28 volts, 24 volt systems) at 60°F (16°C).
3. Water temperature should not rise over 200°F (94°C). If it does, shut down the engine and investigate the cause of overheating.
4. **Do not exceed 800 RPM when shifting marine gear.** Repeated shifts at higher engine speeds can damage the reverse gear.
5. Low Idle is 750 RPM. Maximum working engine speed is: 2100 RPM for pleasure craft, 2000 RPM for light commercial craft and 1800 RPM for continuous duty applications.

OPERATING PROCEDURES

6. If the proper propeller is used, the engine should reach its appropriate maximum speed at full throttle. If at full throttle the maximum speed is exceeded, then the propeller is too small. If maximum speed cannot be attained, then the propeller is too large or bottom growth may be slowing the boat. (See Prop Chart, page 23.)
7. To Establish Maximum Cruising RPM:
Establish the RPM at full throttle and subtract 200-300 RPM. This will promote engine life and reduce fuel consumption.

SHUTDOWN PROCEDURES

1. Run for three to five minute cool down period.
 - a. Propulsion engines in neutral at 1000 RPM, then return throttle to low idle.
 - b. Generators unloaded.
2. Push STOP button until the engine has stopped. Turn key switch to OFF position.
3. Close the sea cock, fuel valves and put the battery switch in OFF position.

NOTE: *Do not turn battery switch to OFF while engine is running.*

SHUTDOWNS AND ALARMS

1. Your unit is fitted with a system to protect it from high water temperature or low oil pressure.
 - a. Generator sets have shutdown systems to stop the engine. They have no warning horns.
 - b. Propulsion engines have warning horns to sound and warn you of a problem. Remember: when engine is not running the horn will sound when key is in the "ON" position because there is no oil pressure. Propulsion engines do not have shutdown systems.
 - c. Other alarms and shutdowns are available as optional equipment.

NOTE: *Do not rely on your warning or shutdown system to the exclusion of careful gauge monitoring. Watching your gauges can prevent damage to the unit and dangerous power losses.*

2. Do the following when your warning or shutdown system is activated.
 - a. Check the temperature gauge. If the temperature is above 200°F (94°C), shut off the engine immediately.
 - b. Use the Trouble Shooting Guide on page 26 to isolate the cause of the overheat.



CAUTION: *Do not remove the water fill cap of an overheated engine. Escaping high temperature steam can cause severe burns.*

- c. **Allow the engine to cool and then remove the cap slowly using protective clothing.**
 - d. Make repairs and restart after the temperature gauge registers below 180°F (82°C).
 - e. Watch the temperature gauge regularly and turn off the unit if the temperature rises above 200°F (94°C). Repeat the troubleshooting process.
3. If the warning or shutdown is activated and the temperature gauge shows temperature within normal temperature range:
 - a. Check the engine crankcase oil level.
 - b. If the oil level is low, fill with recommended lubricating oil and restart. Watch the oil pressure gauge carefully and shut off the engine if it does not show a normal reading after a few seconds of operation.
 - c. If the oil level is normal, DO NOT restart the engine. Call your Northern Lights or Luger dealer for assistance.

BREAK-IN PERIOD

1. The first 100 hours on a new or reconditioned engine are critical to its life and performance.
2. Constantly check the engine temperature and oil pressure gauges.
3. Oil consumption is greater during break-in as piston rings and cylinder liners take time to seat.
4. Break-In Oil Changes: Change engine oil and filter at 50 hours. Change oil and filter again at 100 hours. (See Gear Owner's Manual for break-in oil change procedures. Consult Lubricants Section for oil recommendation.)

Operating Instructions

1. Propulsion engines: **Never run full speed for more than 5 minutes during the first 50 hours.** Run engine at 50 to 75% of maximum working speed for the first 20 hours with as little idling time as possible. Extended idling can inhibit ring seating, causing cylinder walls to glaze.
2. Generator Sets: **Maintain at least a 75% load on your set for the first 100 hours.** If this is not possible, maintain no less than a 50% load to ensure proper seating of the piston rings. Vary the load to help seat rings.

SERVICING SCHEDULE CHART

The Servicing Schedule Chart below shows the service schedule required for proper maintenance of your unit. More detailed coverage of each Service Point (SP) is listed on the page noted in the 'page' column.

DAILY:

- SP1 Check oil level in engine
- SP7 Check primary fuel filter
- SP14 Check cooling water level
- SP21 Check oil level in reverse gear

FIRST 50 HOURS:

- SP2 Change engine oil
- SP3 Change lube oil filter

EVERY 50 HOURS (or weekly):

- SP5 Check V-belt tension
- SP24 Check electrolyte in batteries

FIRST 100 HOURS:

- SP2 Change oil
- SP3 Change lube oil filter
- SP6 Check valve clearances

FIRST 250 HOURS:

- SP20 Change coolant filter

EVERY 250 HOURS (or every 6 months):

- SP2 Change engine oil
- SP3 Change lube oil filter
- SP4 Check air filter

EVERY 250 HOURS (Continued)

- SP8 Change primary fuel filter element
- SP12 Check turbocharger air, oil and cooling lines for leakage
- SP18 Check zinc electrodes. HE engines only

FIRST 500 HOURS

- SP20 Change coolant filter

EVERY 500 HOURS (or yearly):

- SP20 Change coolant filter

EVERY 750 HOURS (or yearly):

- SP4 Replace air filter
- SP6 Check valve clearances
- SP9 Change secondary fuel filter
- SP10 Check injectors
- SP13 Check turbocharger boost pressure
- SP15 Check and flush cooling system
- SP19 Change impeller in sea water pump
- SP25 Check condition of batteries with hydrometer

EVERY 2400 HOURS:

- SP11 Check fuel injection pump
- SP16 Check and clean heat exchanger
- SP17 Check and clean gear oil cooler

SERVICE POINT	PAGE	OPERATION	DAILY	50 Hours	250 Hours	500 Hours	750 Hours	2400 Hours
ENGINE:								
SP1	12	Check oil level	●					
SP2	12	Change engine oil			●			
SP3	12&13	Change lube oil filter			●			
SP4	13	Replace air filter			●		●	
SP5	13	Check V-Belt tension		●				
SP6	13	Check valve clearances					●	
FUEL SYSTEM:								
SP7	14	Check primary filter (Racor)	●					
SP8	14	Change primary filter element			●			
SP9	14	Change secondary filter					●	
SP10	14&15	Check injectors					●	
SP11	15	Check fuel injection pump						●
TURBOCHARGER:								
SP12	17	Check air lines, oil and cooling water lines for leakage			●			
SP13	17	Check boost pressure					●	
COOLING SYSTEM								
SP14	20	Check cooling water level	●					
SP15	20	Check and flush cooling system					●	
SP16	21	Check and clean heat exchanger						●
SP17	21	Check and clean gear oil cooler						●
SP18	21	Check zinc electrodes-HE engines only			●			
SP19	21	Change impeller in seawater pump					●	
SP20	21	Change coolant filter				●		
DRIVEN EQUIPMENT:								
SP21	21	Check oil level in reverse gear	●					
SP22	21	Change oil in reverse gear						
SP23	21	Clutch and PTO service						
ELECTRICAL SYSTEM:								
SP24	22	Check electrolyte level in batteries		●				
SP25	22	Check condition of batteries with hydrometer					●	
OUT OF SERVICE:								
SP26	22	Winterizing or out-of-service						

1) Perform all maintenance once a year even if hour level has not been reached.

2) Consult manufacturer's maintenance schedule, note on chart.

3) When necessary.

4) Change at first 50 and first 100 hours.

5) Adjust at first 100 hours.

SERVICE RECORD

Service Point	OPERATION	HOURS/DATE									
50 HOURS (or weekly)											
SP5	Check V-belt tension										
SP25	Check electrolyte in batteries										
250 HOURS (or every 6 months)											
SP2	Change engine oil										
SP3	Change lubricating oil filter										
SP4	Check air cleaner										
SP8	Change primary fuel filter element										
SP12	Check turbocharger air, oil & cooling lines for leakage										
SP18	Check zinc electrodes - HE engines only										
500 HOURS (or annually)											
SP20	Change cooling system filter										
750 HOURS (or annually)											
SP4	Replace air cleaner										
SP6	Check valve clearances										
SP9	Change secondary fuel filter										
SP10	Check injectors										
SP13	Check turbocharger boost pressure										
SP15	Check and flush cooling system										
SP19	Change impeller in sea water pump										
SP25	Check state of charge of batteries										
2400 HOURS											
SP11	Check fuel injection pump										
SP16	Check and clean heat exchanger										
SP17	Check and clean gear oil cooler										

SERVICING

LUBRICATION - GENERAL

1. Use only clean, high quality lubricants stored in clean containers in a protected area.
2. These lubricants are acceptable:
 - a. API Service CC/CD single viscosity oils.
 - b. API Service CC/CD/SF multi-viscosity oils.
3. Use the proper weight oil for your average operation temperature.

Air Temperature	Single Viscosity	Multi-Viscosity
Above 32°F (0°C)	SAE-30W	SAE 15-40W
-10 to 32°F (-23 to 0°C)	SAE-10W	SAE10-30W
Below -10°F (-23 °C)	SAE-5W	SAE 5-20W

4. Some increase in oil consumption may be expected when SAE 5W and SAE 5-20W oils are used. Check oil level frequently.
5. Never put additives or flushing oil in crankcase.
6. Propulsion Engines: See Gear Owner's Manual for gear lubrication recommendations.

SP1. CHECK OIL LEVEL

1. Check oil in the crankcase daily with the dipstick. The oil level must be in the waffled area between the "L" and "H." Never allow the level to go below the "L."
2. Always add the same viscosity of oil as is already in the crankcase. (See above recommendations.)

SP2. OIL CHANGES

1. Using the oil recommended in the above diagram, change the engine oil and filter after the first 50 hours of operation, the first 100 hours of operation, and every 250 hours thereafter.
2. During intermittent cold weather operation, change oil every 100 hours or six weeks, whichever comes first.
3. Change oil at any seasonal change in temperature when a new viscosity of oil is required.

4. Change oil when engine is warm.
5. Dispose of waste oil in an approved manner.
6. Propulsion Engines with Optional Drain Pump:
 - a. Your engine is fitted with a hand pump that drains the engine crankcase and marine gear.
 - b. Use a wrench to turn the selector valve to drain the engine or gear. Use marks on the valve stem as a guide. (See below).
 - c. Turn pump handle in clockwise direction and pump oil into a suitable container. When the engine is empty, switch the valve and drain the gear oil.
 - d. Close valve. Refill engine and gear with recommended oils.

NOTE: Make sure the valve is in the closed position before starting engine. If it is left open it is possible for crankcase oil to be pumped into the reverse gear and out of the gear dipstick and breather. This can ruin the engine.

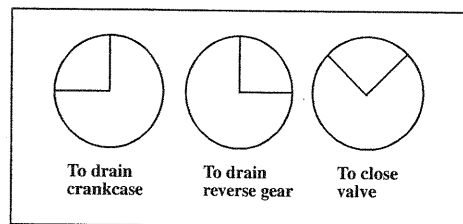

Hand pump selector valve

7. Marine Generator Sets:
 - a. Remove plug from outlet in base frame. Screw in owner-supplied drain hose.
 - b. Open valve at oil pan outlet. After oil has been drained into suitable container, close valve, remove drain hose and replace plug in base frame outlet.
 - c. Refill engine with recommended oil.
8. Engine capacity with new oil filter is 26.4 gallons (100 liters).

SP3. CHANGING OIL FILTER

1. Change the lube oil filter after the first 50 hours of operation, after the first 100 hours of operation and every 250 hours thereafter.
2. Use a filter wrench to remove old filter. Dispose of filter in an approved manner.

SERVICING

3. Make sure the gasket from the old filter is removed and discarded.
4. Lubricate the rubber gasket on the new filter and screw it on nipple until gasket meets the sealing surface.
5. Using hands only, no wrench, tighten filter one-half turn farther. Overtightening can do damage to filter housing.
6. Fill engine with recommended oil. Start engine and check for leakage. Stop engine and check oil level. Add additional oil if necessary.

SP4. AIR FILTER

1. Inspect air cleaner every 250 hours, replace the filter every 750 hours, or yearly, whichever comes first.
2. After replacing element and cover, start engine and check for air leaks.

NOTE: Make absolutely sure no impurities enter the engine while changing the element. Do not run the engine with the air cleaner removed.

SP5. V-BELTS

1. Check the tension and wear on the V-belts after every 50 hours.
2. Use your thumb to press on the belt at the midpoint between the crankshaft and alternator pulleys. The tension is correct if the belts can be depressed about 3/8 in. (10mm).
3. Belts that operate in pairs should both be replaced in pairs, even if only one of them needs to be replaced.

SP6. VALVE CLEARANCES

1. Check the valve clearances after the first 100 hours, and every 750 hours thereafter.
2. Shut off fuel supply. Turn off battery switch.
3. Align the "1.6 TOP" mark on the vibration damper with the pointer using the barring tool (see "Injection Pump Timing" page 15). In this position the No. 1 cylinder is at top dead center of the compression stroke, and the No. 6 cylinder's intake valves will start to move. (See Fig. 8).
4. Adjust the valve clearance for valves marked with an "X" on the chart on this page. This is a two step process:
 - A. First, adjust the crosshead. To do this, loosen the locknut (10-5) and the adjustment screw (10-6). Press the top of the crosshead lightly with you fingers and tighten the adjustment screw by hand

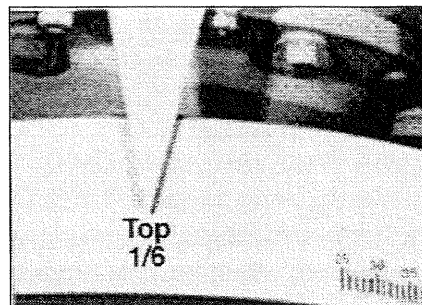

Figure 8. Timing Mark

Cylinder No.	1	2	3	4	5	6
Intake Valve	X	X	O	X	O	O
Exhaust Valve	X	O	X	O	X	O

Figure 9. Valve Clearance Chart

until it contacts the valve stem, then tighten screw an additional 20°. Retighten locknut to 28 ± 3 lb.-ft.

- B. The second step is adjusting the valve clearance itself. Loosen nut (Fig. 10-1) on the adjustment screw (10-2), insert feeler gauge between crosshead (10-3) and rocker arm (10-4) and adjust the clearance with adjustment screw until the thickness gauge slides with a slight drag. After the clearance is properly adjusted tighten the lock nut using 43 ± 7 foot lbs. of torque (6 ± 1.0 kgm.)
5. Rotate the crankshaft in the direction of engine rotation one complete revolution until "1.6 TOP" is again at the pointer and adjust the valve clearance for the valves marked with an "O" in chart.
6. Valves should be set cold or hot with the following clearances:
 - a. Intake Valves - .016 in (.4 mm)
 - b. Exhaust Valves - .040 in (1.0 mm)

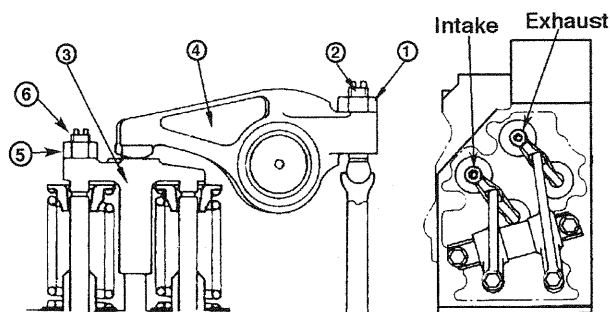

Figure 10

SERVICING

FUELS - GENERAL

1. Use only clean, high quality fuels of the following specifications, as defined by ASTM designation D975 for diesel fuels:
 - a. Use grade No. 2 diesel at ambient temperatures above freezing 32°F (0°C).
 - b. Use grade No. 1 at ambient temperatures below freezing and for all temperatures at an altitude of above 5,500 ft. (1500 meters).
2. Use fuel having less than 1% sulphur (preferably less than 0.5%).
3. The cetane number should be a minimum of 45.
4. DO NOT use these unsuitable grades of fuel:
 - a. Domestic heating oils, all types.
 - b. Class B engine.
 - c. Class D domestic fuels.
 - d. Class E, F, G or H industrial or marine fuels.
 - e. ASTM-D975-60T No. 4-D and higher number fuels.
5. Storing fuel:
 - a. Keep dirt, scale, water and other foreign matter out of fuel.
 - b. Avoid storing fuel for long periods of time.
 - c. Fill the fuel tank at the end of each day's operation. This will reduce condensation.

SP7-9. FUEL FILTERS

1. Your engine or generator set should have a primary fuel filter installed. We recommend the Racor brand of fuel filter - water separators.
 - a. Check the primary fuel filter daily as recommended by the filter manufacturer. Empty the collection bowl as necessary.
 - b. Change the element every 250 hours or when necessary.
 - c. If the bowl fills with water, change the primary and secondary element immediately.
2. Change secondary fuel filter every 750 hours.
 - a. Remove the filter cartridge by turning it counterclockwise with a filter wrench. Fill the new cartridge with fuel and install it after applying engine oil to gasket surface. Screw on until the gasket surface comes into contact with sealing surface of filter base. Then, tighten it two-thirds of a turn by hand.

BLEEDING THE FUEL SYSTEM



CAUTION: Escaping diesel fuel under pressure can penetrate the skin, causing serious personal injury. Before disconnecting lines be sure to relieve all pressure. Before applying pressure to the system be sure all connections are tight and the lines, pipes and hoses are not damaged. Fuel escaping from a very small hole can be almost invisible. Use a piece of cardboard or wood, rather than the hands, to search for suspected leaks. If injured by escaping fuel, see a doctor at once. Serious infection or reaction can develop if proper medical treatment is not administered immediately.

1. Whenever the fuel system has been opened for service, (lines disconnected, filter changed, etc.) it should be bled.
2. To bleed the fuel system, loosen the vent plug in the top of the fuel filter housing. Unscrew the hand primer knurled knob on the injection pump and loosen until it can be pulled up by hand. Operate the hand primer up and down until most of the air bubbles are expelled and clear fuel escapes the vent plug. Push hand primer down and tighten. Tighten the vent plug.
3. If the engine will not start, it may be necessary to loosen the fuel pipes at the injectors. With the throttle on full, crank the engine over with the starter until fuel without air flows from the loose fuel pipe connections. Tighten the connections.

SP10. INJECTORS

1. Fuel injectors should be checked by a Luggen-Northern Lights dealer or qualified fuel injection shop after every 750 hours.
2. Injector Removal:
 - a. Thoroughly clean the area around injection pump, fuel line connecting nuts and rocker arm housing cover.
 - b. Remove fuel line nuts on fuel inlet connector and injection pump. Remove fuel line clamps. Pull fuel lines loose.
 - c. Remove return line.
 - e. Remove rocker arm cover.
 - f. Lift out injector.
3. Clean Injector Bore:

Injector seat in cylinder head can be cleaned by wrapping a clean, lint-free rag around the tapered

SERVICING

INJECTORS cont.

end of a wooden rod and wiping the bore and seat. Hardened carbon can be removed from the seat by using a tapered wire brush to break carbon free. Then clean the bore with rag and rod.

4. Have injectors tested and rebuilt if necessary. Or, take them to a Luggar-Northern Lights dealer and use them as core exchange for rebuilt injectors.
5. Injector Installation:
 - a. Insert injector, aligning indexing marks on hold down plate with mark on injector body.
 - b. Install injector hold down bolts and torque to 20 foot lbs. (2.75 kgm.)
 - c. Install rocker arm cover.
 - d. Install return lines.
 - e. Install injector lines. Torque fuel line nuts to 40 ft. lbs. (5.5 kgm).
 - f. Bleed the fuel system, start the engine and check the system for leaks using a piece of cardboard.

SP11. INJECTION PUMP

1. The pump settings, maximum speed, idle speed, and exhaust smoke should be checked after every 2400 hours of operation. Service of the fuel injection pump should only be done if checks indicate pump malfunction.
2. Low power and no smoke can indicate a fuel injection pump malfunction. Check for full throttle, proper solenoid adjustment, turbo lines for air leaks, and air filter cleanliness before replacing pump. Black smoke occasionally may indicate an injection pump problem.
3. Any repair which involves disassembly of the injection pump must be carried out by specially trained mechanics with the proper tools and test devices.

NOTE: All warranties on the engine become null and void if the injection pump seals are broken by unauthorized persons.

4. Injection Pump Removal:
 - a. Clean injection pump, hoses and area around the pump with cleaning solvent or a steam cleaner.

NOTE: Never steam clean or pour cold water on an injection pump while the engine is running or the pump is warm.

- b. Remove line clamps (see Fig. 12-1) and fuel injection lines (Fig. 12-2).
 - c. Remove feed lines (Fig. 12-3) and lubrication tubes (Fig. 12-4 & 12-5) and return line (Fig. 12-6).
 - d. Remove coupling bolts (Fig. 14-c) between the coupler (14-b) and the flange (Fig. 14-a) on the pump drive.
 - e. Remove the six mounting bolts (Fig. 12-7) which hold the injection pump on the bracket.
5. Injection Pump Installation:
 - a. Position pump on bracket. Positioning sleeves on two of the bolt holes help align the pump.
 - b. Tighten six mounting bolts (see Fig. 12-7) to 49-54 foot lbs (6.75-7.50 kgm).
 - c. Reinstall coupling (Fig. 14-c) bolts, but do not tighten them until pump is timed as per next section.
 - d. Reinstall feed lines (Fig. 12-3) and lubrication oil lines (Fig. 12-4 & 12-5) using new gasket washers on both sides of banjo bolts.
 - Torque nuts for line (Fig. 12-5):
18-21.6 foot lbs. (2.5-3 kgm)
 - Torque nuts for line (Fig. 12-4):
11-14 foot lbs. (1.5-2 kgm)
 - e. Reinstall fuel injection lines (Fig. 12-2) and line clamps (Fig. 12-1). Fuel delivery line sleeve nuts (Fig. 12-8) torque to 16-18 foot lbs. (2.4-2.5 kgm).

INJECTION PUMP TIMING

1. The Match Mark Alignment Method:

This is used when the injection pump is installed on the original engine and the pump has NOT been repaired.

 - a. Turn the crankshaft with the barring tool in normal engine rotation direction to bring the number one cylinder to top dead center of the compression stroke. The compression stroke can be determined by removing the number one cylinder valve cover and turning the engine until all valves are closed.
 - b. The barring tool (Fig. 12-12, 11-A) is located on the injection pump side, flywheel end of the engine. A pin (Fig. 11-B) must be removed and the tool pushed in to engage.

SERVICING

- c. To remove the gear lash, turn crankshaft in opposite direction of rotation a minimum of 45° (1/8 turn).
- d. Align the appropriate crankshaft timing mark on crankshaft damper. This is done turning the barring tool in direction of engine rotation, checking the timing mark as you go and stopping when the arrow points exactly at timing number indicated on data tag located on right rear of block. *Do not go past the timing mark.*
- e. Remove the coupling cover (Fig. 12-14). Check the stamped line on the injection pump (Fig. 14-a) and on the coupling (Fig. 14-b). They should be aligned.
- f. If the stamped lines are out of alignment, loosen nuts (Fig. 14-c) and align the stamped lines by shifting the coupling side. Retighten the nuts to 43-46 lbs. torque (5.9-6.2 kg).
- g. Replace the barring tool pin and coupling cover.

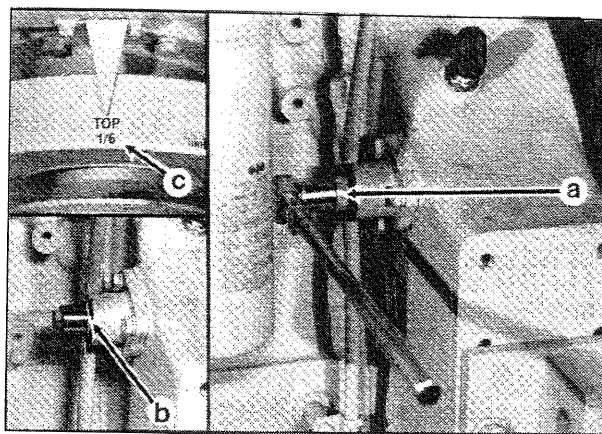

Figure 11

2. Delivery Valve Method:

Use delivery valve method when a repaired or replaced injection pump is installed.

- a. Disconnect fuel injection line from the No. 1 cylinder delivery valve on the injection pump (see Fig. 15-a).
- b. Remove coupling cover (Fig. 12-14). Remove delivery valve holder. Remove spring and delivery valve and put valve holder back in injection pump.

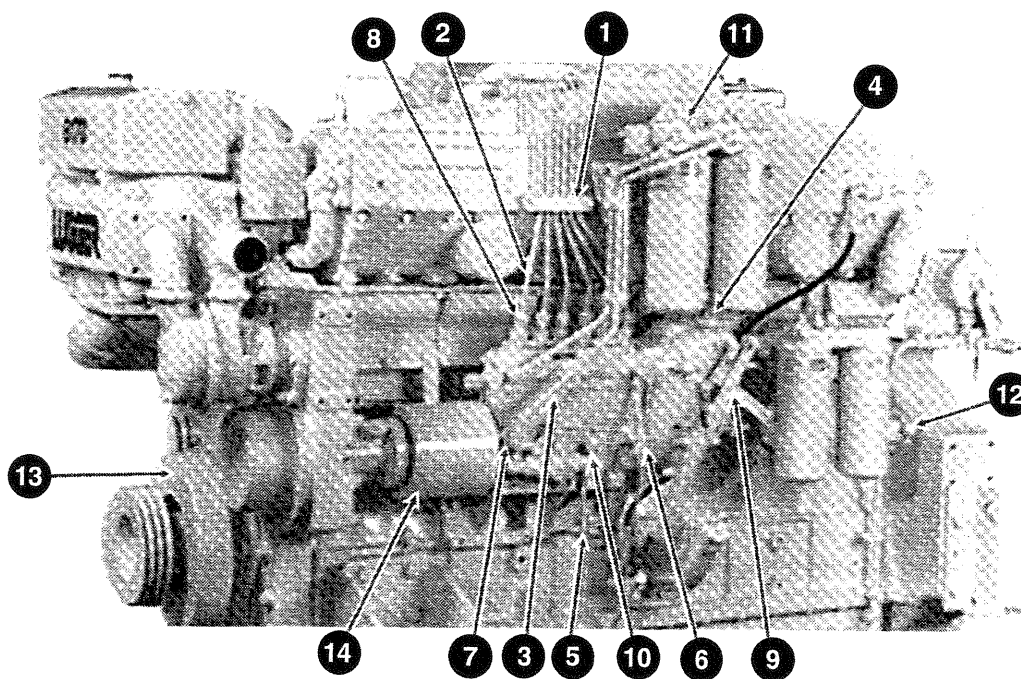

Figure 12. Injection Pump Servicing Points

- | | | | |
|-----------------------------|------------------------------|-----------------------|-----------------------|
| 1. Injection line clamps | 5. Lubrication line (outlet) | 9. Throttle | 12. Barring tool |
| 2. Fuel injection line | 6. Fuel return line | 10. Hand priming pump | 13. Crankshaft damper |
| 3. Fuel feed line | 7. Pump mounting bolts | 11. Air vent point. | 14. Coupling cover |
| 4. Lubrication line (inlet) | 8. No. 1 delivery line | | |

SERVICING

- c. Place the throttle (Fig. 12-9) in the full fuel (forward) position.

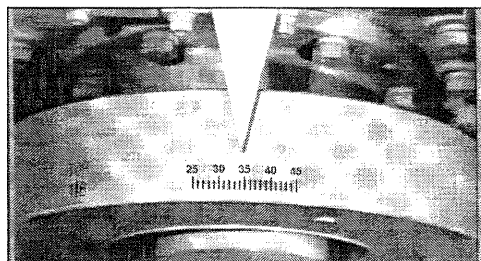

Figure 13

- d. Slowly rotate the crankshaft with the barring tool in the direction of engine rotation while operating the priming pump (Fig. 12-10, 15-b). This is best done by two people.

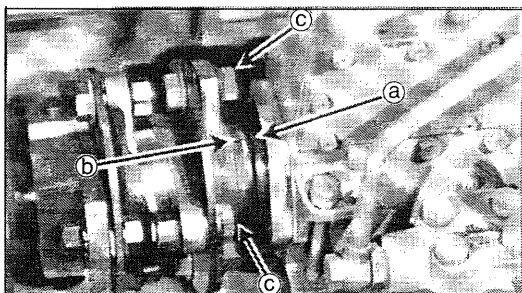

Figure 14

- e. Stop rotating and pumping when fuel stops flowing out of the delivery valve holder (Fig. 15-c).
- f. Check the crankshaft timing mark on the crankshaft damper to see if it is aligned with the pointer (Fig. 13).
- g. Turn the crankshaft 45° (1/8 turn) in the opposite direction of rotation.
- h. Align the crankshaft timing mark (Fig. 13) on the damper with the pointer by slowly rotating the crankshaft in the direction of engine rotation.
- i. Adjust the timing. To do this, remove the two bolts (Fig. 14-c) on the coupling. Rotate the coupling on the pump side little by little while operating the priming pump (Fig. 15-b) until no fuel flows out of the delivery valve holder (Fig. 15-c). If the slots do not allow enough adjustment, call Alaska Diesel Electric.

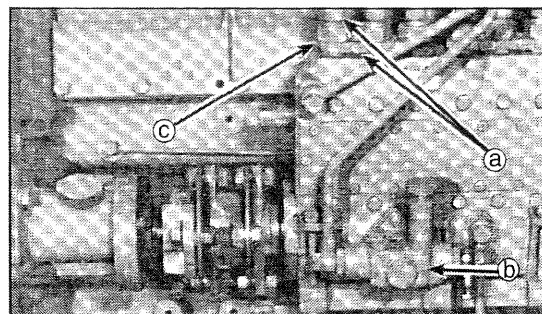

Figure 15

- j. Replace the two bolts (Fig. 14-c). Now re-check the injection timing to see it is properly adjusted by repeating steps d & e.
- k. If line "b" on coupling does not align with the line "a" on the pump, re-stamp coupling with new line.
- l. Reassemble the delivery valve and reinstall fuel lines (see Fig. 12-2) and clamps.
- m. Bleed fuel system.

SP12. TURBOCHARGER

1. Check for air leaks every 250 hours. Air leakage will lower engine output and may cause black exhaust smoke and soot.
2. Listen along air line while engine is running. A whistling or hissing sound indicates leakage.
3. Leakage on the pressure side, between turbo and engine, can be found by applying soapy water to the air line.
4. Tighten the hose clamps, replace hose or gaskets as required.
5. Check to see that the lubrication and cooling lines are tight and without leaks.

SP13. TURBO BOOST

1. This check measures the amount of air the turbo is pushing into the engine. It should be done by an authorized dealer every 750 hours.
2. Your engine can have a boost gauge permanently installed so you can monitor the turbo's output from the control panel.

SERVICING

COOLING REQUIREMENTS

1. To meet cooling system protection requirements, the coolant solution must consist of:
 - a. **Quality water**
 - b. **Ethylene glycol concentrate (EGC) commonly known as antifreeze.**
 - c. **Supplemental coolant additives (SCA's).**
2. A coolant solution of ethylene glycol concentrate (EGC-antifreeze), quality water and supplemental coolant additives (SCA's) **MUST** be used **YEAR ROUND** to protect against freezing, boil-over, liner erosion or pitting and to provide a stable, noncorrosive environment for cooling system components.
3. **Ethylene glycol coolant concentrate (anti-freeze) normally DOES NOT contain the SCA chemical inhibitors needed to control liner pitting or erosion, rust, scale, and acidity.**
4. Your engine is equipped with a spin-on coolant filter conditioner element which provides the SCA's to protect your cylinder liners.
5. The coolant filter conditioner element performs two functions at once:
 - The outer paper element filters out rust, scale or dirt particles in the coolant.
 - The inner element releases chemicals into the coolant to maintain a proper acid/alkaline balance, inhibit corrosion and suppress erosion pitting.

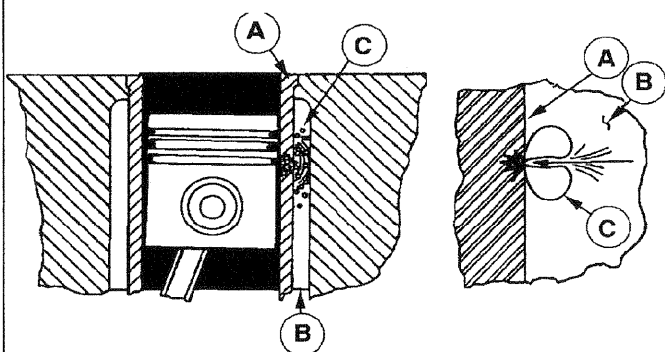

A - Cylinder Liner Walls
 B - Engine Coolant
 C - Vapor Bubbles

LINER EROSION (PITTING)

1. Cylinder liner walls (A) which are in contact with engine coolant (B) can be eroded or pitted unless the proper concentration and type of SCA's are present in the coolant. Water pump impellers are also susceptible to pitting.
2. Vapor bubbles (C) are formed when the piston's impact causes the liner walls to vibrate, sending pressure waves into the coolant.
3. These tiny vapor bubbles collect on the surface of metal parts. As the bubbles collapse (pop) a microscopic piece of metal is eroded from the metal part. Over a period of time, this pitting may progress completely through the cylinder liner of a wet-sleeve, heavy-duty diesel engine. This allows coolant to enter the combustion chamber. Engine failure or other serious damage will result.
4. Unprotected engines with low quality water as coolant can have liner failure in as few as 500 hours.
5. The SCA's released by the filter will significantly reduce erosion and pitting. The chemicals in the additives reduce the quantity of vapor bubbles. It also forms a protective film on the metal engine parts which act as a barrier against collapsing vapor bubbles.

WATER QUALITY

1. Distilled, deionized, soft water is preferred for use in cooling systems. Bottled distilled water from a food store or water supplier is recommended. Tap water often has a high mineral content. Tap water should **NEVER** be put in a cooling system unless first tested by a water quality laboratory.
2. Here are acceptable water quality specifications:

Contaminates	Parts Per Million	Grains Per Gallon
Maximum Chlorides	40	2.5
Maximum Sulfates	100	5.9
Max Dissolved Solids	340	20
Max Total Hardness	170	10
PH Level 5.5 to 9.0		

3. If chlorides, sulfates or total dissolved solids are higher than the above given specification, the water must be distilled, demineralized, or deionized before it is used in a cooling system.

SERVICING

4. If total hardness is higher than 170 ppm and all other parameters are within the given specifications, the water must be softened before it is used to make coolant solution.

ETHYLENE GLYCOL CONCENTRATE - EGC (ANTIFREEZE)



CAUTION: EGC (Antifreeze) is flammable. Keep it away from any open flame. Avoid contact with eyes. Avoid contact with skin. Do not take internally. In case of contact, immediately wash skin with soap and water. For eyes, flush with large amounts of water for at least 15 minutes. Call a physician. KEEP OUT OF REACH OF CHILDREN. Follow all warnings on the container.

1. Ethylene glycol coolant concentrate is commonly mixed with water to produce an engine coolant with a low freeze point and high boiling point.
2. A *low silicate* form of ethylene glycol coolant is recommended for all diesel engines.
3. Use an ethylene glycol coolant concentrate meeting ASTM D 4985P, SAEJ1941, General Motors Performance Specification GM1899M, or formulated to GM6038M.
4. This product is concentrated and should be mixed to the following specification.

	Distilled Water %	EGC % Antifreeze	Freeze Point	Boiling Point
Optimum	50%	50%	-37°C -34° F	+109°C +226° F
Minimum	60%	40%	-24°C -12° F	+106°C +222° F
Maximum	40%	60%	-52°C -62° F	+111°C +232° F

5. If additional coolant solution needs to be added to the engine due to leaks or loss, the glycol concentration should be checked with a hydrometer to assure that the desired freeze point is maintained.
6. **IMPORTANT**
DO NOT use methyl alcohol or methoxy propanol base EGC. These concentrates are not compatible with chemicals used in supplemental coolant additives. Damage can occur to rubber seals on cylinder liners which are in contact with coolant.

DO NOT use an EGC containing sealer or stop-leak additives.

DO NOT use EGC containing more than 0.1% anhydrous metasilicate. This type of concentrate, which is intended for use in aluminum engines, may cause a gel-like deposit to form that reduces heat transfer and coolant flow. Check container label or consult with supplier.

SUPPLEMENTAL COOLANT ADDITIVE (SCA)



CAUTION: Supplemental coolant additive contains alkali. Avoid contact with eyes. Avoid contact with skin. Do not take internally. In case of contact, immediately wash skin with soap and water. For eyes, flush with large amounts of water for at least 15 minutes. Call a physician. KEEP OUT OF REACH OF CHILDREN. Follow all warnings on the container.

1. Your engine is equipped with a spin-on coolant filter conditioner element which provides the SCA's to protect your cylinder liners. The inner element releases chemicals into the coolant to maintain a proper acid/alkaline balance, inhibit corrosion and suppress erosion pitting.
2. **Important: All engines.**
ALWAYS change the coolant conditioner-filter element according to the service chart in this manual.
3. **Important: Radiator and Heat Exchanger cooled engines.**
Additional SCA's should NOT be added to the mixture of EGC/H₂O on initial fill up of engines with a coolant conditioner-filter. A high SCA concentration will result and can cause silicate-dropout. When this happens, a gel-type deposit is created in the cooling system which retards heat transfer and coolant flow.
4. **Important: Engines with Keel Cooling.**
The SCA in the spin-on filter may not be able to treat the large volume of coolant in a vessel's keel cooling system. The operator must use a test kit strip to determine the amount of additional SCA's that need to be added to the cooling system.

SERVICING

SCA'S CONTINUED

If additional SCA's are needed, prepare a mixture of 50% quality water and 50%EGC (anti-freeze). Add liquid SCA at a rate of 3%, by volume.

Example: 30 mL of SCA per liter of H₂O/EGC mixture. (1.0 fl oz of SCA per qt of H₂O/EGC). Add the resulting mixture to the cooling system in quart increments. Run the engine for 2 hours and re-test the coolant. Continue process until SCA concentration meets recommended levels.

5. SCA is available from your Northern Lights/Lugger dealer in the following sizes.
Pint - Part Number.....20-00002
1/2 gallon - Part Number.....20-00003
6. **DO NOT** use any coolant system additives containing soluble oil.

COOLANT TESTING

1. Coolant test kits are available to allow on-site evaluation of the coolant condition.
2. The kits use small strips of paper which are dipped into the coolant. The paper changes color and indicates the SCA concentration. It also indicates the amount of EGC (antifreeze).
3. Test kits are available through your Northern Lights or Lugger Dealer.
4 Pack - Part Number.....20-00005

SP14. CHECKING COOLANT LEVEL.



CAUTION: *The cooling water in the engine reaches extremely high temperatures. You must use extreme caution when working on hot engines to avoid burns. Allow the engine to cool before working on the cooling system. Open the filler cap carefully, using protective clothing when the engine is warm.*

1. Check the coolant level each day before starting the engine. Check the coolant level by removing the pressure cap from the expansion tank. In order to give the coolant an opportunity to expand, the level should be about 1 3/4 in. (4-5 cm) below the filler cap sealing surface when the engine is cold. When filling with coolant, the venting cock on top of the turbocharger should be opened to ensure that no air pockets form in the cooling system.

2. The pressure valve in the filler cap releases when the pressure is approximately 7 PSI (0.5 bar). Use a cap pressure tester to check cap if you suspect it is faulty.
4. The makeup coolant, added to compensate for loss or leaks, must meet engine coolant requirements outlined in previous section.

SP15. FLUSHING THE COOLING SYSTEM



CAUTION: *The cooling water in the engine reaches extremely high temperatures. You must use extreme caution when working on hot engines to avoid burns. Allow the engine to cool before working on the cooling system. Open the filler cap carefully, using protective clothing when the engine is warm.*

IMPORTANT

Be sure to close the sea cock before working on the engine cooling system.

1. Flush the cooling system and check for leaks and blockage every 750 hours, or yearly.
2. The engine must be stopped and cold. Remove the filler cap with caution. Open cooling system air vents on top of the turbocharger, at the front and rear of the aftercooler and for heat exchanged units on top of heat exchanger (HE).
3. Drain the jacket (fresh) water circuit of the cooling system. On the exhaust manifold the drain is under manifold near rear of the engine, keel cooled and heat exchanged. On the engine block the drains are on the water pump outlet and turbo coolant line one foot behind starboard front mount, KC & HE. On the gear oil cooler at the bottom of right gear oil cooler elbow (propulsion engines only), KC & HE. On the remote expansion tank remove hose from bottom of tank.
4. To drain the raw water circuit of HE engines, open the drain at the starboard end cap of the heat exchanger.
5. With drains open, pour clean water into the filler cap. When the water from each drain is clear and free from discoloration and sediment, close that drain. When all drains are closed, flushing is complete.
6. Re-drain the engine and refill the jacket (fresh) water circuit with coolant mixture as described in previous section.

SERVICING

7. Close cooling system air vent.
8. Open sea cock.
9. Start engine. Monitor temperature gauge carefully and check cooling system for leaks.

SP16. HEAT EXCHANGER CLEANING

1. Clean the heat exchanger core once a year or after 2400 hours of operation.
2. Drain expansion tank and heat exchanger.
3. Remove heat exchanger covers.
4. Clean the inside of exchanger core tubes using a metal rod.
5. Re-assemble using new gaskets. Fill the cooling system, start the engine and check for leaks.

SP17. CLEANING GEAR OIL COOLERS

For propulsion engines only:

1. Drain fresh water cooling circuit.
2. Remove end covers of gear oil cooler.
3. Wash the core in diesel fuel and blow it dry with compressed air. Clean the end covers of the core with a steel brush and use a metal rod to clean inside of tubes.
4. Re-assemble using new gaskets. Fill the cooling system, start the engine and check for leaks.

SP18. ZINC ELECTRODES

1. Zincs are installed in the heat exchanger cooling system to protect your engine from electrolysis. Check them faithfully every 250 hours. If you are in warm salt water or where electrolysis is a known problem, check them more often. Keel cooled engines do not have zincs.
2. Heat exchanger cooled engines: Drain the raw water from heat exchanger, then drain the expansion tank. Remove zinc holders from back end of heat exchanger and raw water pipe elbow.
3. Scrape or steel brush the zinc electrode clean. If more than 50% of the electrode is corroded away, replace it with a new one. The electrode screws out of the holder.
4. Re-install the zinc holders. Be sure the threads are clean for good metal-to-metal contact.
5. Refill cooling system, start engine, check for leaks.

SP19. RAW WATER PUMP

1. Heat exchanger cooled engines only. Check for leaking seal by inspecting seal drain hole.

SP20. COOLANT FILTER

1. Change coolant filter after the first 250 hours, the first 500 hours and every 500 hours thereafter.
2. Shut off both valves on filter body.
3. Use filter wrench to remove filter.
4. Make sure old gasket is removed.
5. Lubricate new filter gasket and screw on new filter until gasket meets housing.
6. Hand tighten two-thirds of a turn more.
7. Open valves on filter body.
8. Start the engine and check for leaks.
9. Stop engine and check water level in expansion tank.

SP21,22,23. GEARS, PTOS AND GENERATORS

1. Manufacturer's service recommendations vary. See your Owner's Manual for service information. If you do not have a manual, see your local dealer for the equipment in question.

NOTE: Some PTO and marine gears have rigid lubrication requirements. Follow service recommendations closely.

2. If you have a Northern Lights generator set, the maintenance and operation recommendations for the generator end are in a separate Owner's Manual. If you do not have one of these manuals, contact your local Northern Lights dealer.

ELECTRICAL SYSTEM - GENERAL

1. Never switch battery switch off or break the circuit between the alternator and batteries while the engine is running. Regulator damage can result.

SERVICING

2. Do NOT reverse the polarity of battery cables when installing the battery.
3. When welding on the unit, disconnect the regulator and battery. Isolate the leads.
4. Disconnect battery cables when servicing the DC alternator.
5. Never test with a screwdriver, etc., against any terminal to see if it emits sparks.
6. Do not polarize the alternator or regulator.
7. A DC circuit breaker protects your control panel and wiring harness.

BOOSTER BATTERIES

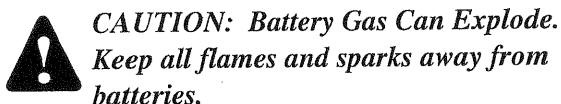

1. Before changing or using booster batteries, check battery electrolyte level. Add distilled water if necessary.
2. Booster and main batteries must have the same voltage rating.
3. First, connect positive (+) terminal of booster battery to positive (+) terminal of main battery. Then, connect negative (-) terminal of booster battery to ground on the engine block (see Fig. 16).

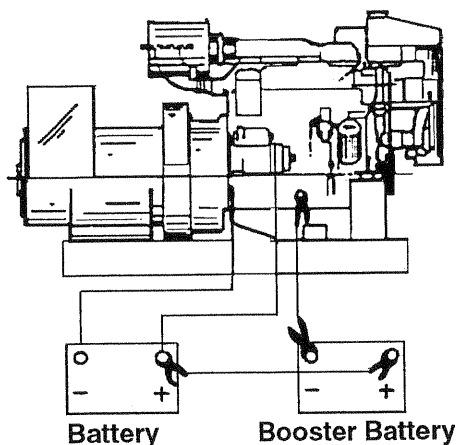

Figure 16. Booster Battery Connections.

4. Remove booster battery after starting engine.
5. Sealed batteries: see manufacturer charging and booster instruction.

SP24,25. BATTERY CARE

1. Check electrolyte level every 50 hours or weekly. Add distilled water to manufacturer's recommended level.
2. Batteries, cables, and cable terminals should be checked and cleaned every 100 hours. Clean corrosion with a water and baking soda solution. Flush with clean water. Tighten terminals and grease them to inhibit corrosion.
3. Check the battery condition with a hydrometer every 750 hours or yearly.

SP26. WINTERIZING, OUT-OF-SERVICE

MARINE

1. Drain seawater cooling systems completely. Remember to shut off sea cocks before opening drain cocks.
2. Drain seawater supply lines and wet exhaust line.
3. Loosen the seawater pump cover and drain pump.
4. Check freshwater antifreeze mixture. If refilling, run the engine up to operating temperature to circulate the antifreeze.
5. Fill fuel tank and add biocide as per manufacturer's instructions.
6. Seal air cleaner inlet, exhaust opening, crankcase breather pipe and fuel tank vent with plastic bags and tape.
7. Change the crankcase oil and filter.
8. Loosen drive belts.
9. Disconnect and clean battery. Remove to warm storage place if possible.
10. Clean outside of unit. Paint any scratched or chipped surfaces. Put corrosion preventative on all exposed metal surfaces.

THREE BLADED PROPELLER SIZING CHART

Use this chart to find approximate propeller sizes for boats with a single engine using a *three blade* propeller and gears with a 3% loss factor.

NOTE: Prop size is influenced by many factors (hull design, load, boat use). It is impossible to make an absolute recommendation. For more accurate recommendations, contact your dealer.

- 1) Find the boat speed your boat builder expects from an engine of this horsepower in the left column.
- 2) Locate the gear ratio desired on the top line.
- 3) Find where two columns intersect for an approximate propeller size. See the column bottom for shaft RPM and shaft diameter.
Example: 460 HP rating; 20 knot boat with 2:1 gear needs a 30 x 29 three blade propeller.

High Output Rating: 900 flywheel HP at 2100 RPM

Speed	Gear Ratios and Propellers						
Knots	1:1	1.5:1	1.75:1	2:1	2.5:1	3:1	3.5:1
11 - 13	—	—	—	—	42x24	46x30	50x34
13 - 15	—	—	—	36x22	42x27	46x36	50x40
15 - 17	—	—	33x22	36x24	42x30	46x40	50x46
17 - 19	—	30x20	33x24	36x28	42x35	46x44	50x52
19 - 21	24x16	30x22	33x27	36x32	42x40	46x48	50x58
21 - 23	24x17	30x26	33x29	36x35	42x44	46x52	—
23 - 25	24x18	30x28	33x32	36x38	42x48	46x56	—
25 - 27	24x19	30x30	33x34	36x40	42x52	—	—
27 - 29	24x20	30x32	33x37	36x43	—	—	—
29 - 31	24x21	30x34	33x39	—	—	—	—
Sft. rpm	2100	1400	1200	1050	840	700	600
Sft. dia. in	1.75	2.25	2.5	3.0	3.5	4.0	4.5

Medium Duty Rating: 800 flywheel HP at 2000 RPM

Speed	Gear Ratios and Propellers						
Knots	1.5:1	1.75:1	2:1	2.5:1	3:1	3.5:1	4:1
9 - 11	—	—	—	—	46x25	52x30	55x34
11 - 13	—	—	—	42x25	46x30	52x34	55x40
13 - 15	—	—	36x22	42x30	46x34	52x39	55x44
15 - 17	—	34x22	36x28	42x35	46x40	52x48	—
17 - 19	31x22	34x26	36x30	42x38	46x46	—	—
19 - 21	31x25	34x29	36x34	42x42	—	—	—
21 - 23	31x29	34x32	36x37	—	—	—	—
Sft. rpm	1333	1140	1000	800	666	571	500
Sft. dia. in	2.25	2.5	3.0	3.5	4.0	4.5	5.0

Continuous Duty Rating: 700 flywheel HP at 1800 RPM

Speed	Gear Ratio and Propellers						
Knots	2.5:1	3:1	3.5:1	4:1	4.5:1	5:1	6:1
5 - 7	—	—	—	—	60x26	62x30	72x36
7 - 9	—	—	—	58x34	60x36	62x40	72x46
9 - 11	—	—	52x34	58x40	60x44	—	—
11 - 13	42x30	48x36	52x40	58x48	—	—	—
13 - 15	42x34	48x40	52x48	—	—	—	—
Sft. rpm	720	600	514	450	400	360	300
Sft. dia. in	3.5	4.0	4.5	5.0	6.0	6.0	7.0

LUGGER DATA

Displacement 1413 in³ (23.15 liters)
Bore x Stroke 6.69 in (170 mm) x 6.69 in (170 mm)
High Output 900HP/2100RPM
Medium Duty 800HP/2000RPM
Continuous Duty 700HP/1800RPM

Approximate dry weight:

Keel cooled, less gear 5525 lbs (2505 kg)
 Heat exchanger cooling, less gear .. 5725 lbs (2596 kg)

Cooling (General)

Freshwater circulating flow at rated speed
 High Output 235 US gpm (889 lpm)
 Medium Duty 224 US gpm (848 lpm)
 Continuous Duty 178 US gpm (674 lpm)
Heat rejection to jacket water
 High Output 25,400 BTU/min
 Medium Duty 23,100 BTU/min
 Continuous Duty 21,770 BTU/min

Cooling (Heat Exchanger)

Raw-water intake diameter 3 in (75 mm)
 Raw-water discharge diameter 3 in (75 mm)
Raw-water pump flow at rated speed
 High output 143 US gpm (543 lpm)
 Medium Duty 136 US gpm (517 lpm)
 Continuous Duty 122 US gpm (465 lpm)
 Raw-water pump maximum suction head 39 in (1 m)
 Maximum raw-water temperature at inlet 85° F (30° C)
 Freshwater system capacity-eng. only 24.6 US gal (93 ltr)

Cooling (Keel Cooled)*

Water hose inside diameter 3 in (76 mm)
 Keel cooler head diameter 3 in NPT
Turbo tube length, High Output 120 ft (36.6 m)
 Medium Duty 100 ft (30.5 m)
 Continuous Duty 90 ft (27.4 m)
Skin cooler-aluminum, High Output 125 ft² (12 m²)
 Medium Duty 112 ft² (11 m²)
 Continuous Duty 96 ft² (9 m²)
Skin cooler-steel, High Output 415 ft² (40 m²)
 Medium Duty 375 ft² (36 m²)
 Continuous Duty 320 ft² (30 m²)

DC Electrical

Voltage 24 volt standard, 12 volt optional
 Minimum battery capacity 225 amp hrs/1150 cca
 Battery cable size "00" up to 10 ft run
 Standard instrument harness length 20 ft (6 m)

Air Intake and Exhaust

Engine air consumption at rated speed
 High Output 1900 f³/min (53.8 m³/min)
 Medium Duty 1729 f³/min (48.9 m³/min)
 Continuous Duty 1500 f³/min (43.0 m³/min)

Minimum engine room intake vent area

High Output 550 in² (0.54 m²)
 Medium Duty 490 in² (0.32 m²)
 Continuous Duty 425 in² (0.27 m²)

Exhaust gas flow at rated speed

High Output 5100 f³/min (144 m³/min)
 Medium Duty 4628 f³/min (131 m³/min)
 Continuous Duty 4320 f³/min (123 m³/min)

Maximum exhaust gas temperature at rated speed

High Output 890°F (476°C)
 Medium Duty 862°F (461°C)
 Continuous Duty 760°F (404°C)

Maximum exhaust back pressure 30 in (762 mm) H₂O

Suggested dry exhaust I.D.

High Output: 8 inch Med. & Continuous Duty: 8 inch
 Suggested wet exhaust I.D.
 High Output: 12 inch., Med.: 12 inch, Contin. Duty: 6 inch

Fuel and Oil

Minimum fuel line:
 Suction (return) 5/8 "-16 mm
Maximum fuel pump head 39 in (1 m)
Crankcase oil capacity 26.4 gallons (100 ltr)

Gear, PTO, Engine Angle

Engine rotation (facing flywheel)
 Counter-clockwise
Flywheel housing size
 SAE #0, 18" (SAE #1, 14" optional)
Front PTO size (optional)
 SAE #3, 11", (SAE #4)

Max. operating angle:

Any direction 25° for less than 2 minutes
Max. installed operating angle
 12° rear down, 0° front down

*Note:

Based on 70° F (21°C) seawater temperature and minimum boat speed of 8 knots at full rpm. Return water 120-165°F (50-75°C).

NORTHERN LIGHTS MARINE SPECIFICATIONS

Model Number	M6170A	M6170A
AC Output¹	1800 RPM 520 kW @ 480 VAC	1500 RPM 440 kW
Phase	3	3
RPM/ Hz	60	50
Voltages 60 Hz	120/208, 120/240, 127/220, 139/240, 220/380, 240/416, 254/440 and 277/480	
Voltages 50 Hz	110/190, 110/220, 115/230, 120/208, 127/220, 220/380, 240/416	
 Engine		
Aspiration	Turbo/AC	Turbo/AC
Cylinders	Inline 6	Inline 6
Displacement cu. in. (l)	1413 (23.15)	1413 (23.15)
Bore in (mm)	6.69 (170)	6.69 (170)
Stroke in (mm)	6.69 (170)	6.69 (170)
 Specific Fuel Rate ⁽³⁾ lb/bhp/hr	 0.364	 0.353
Fuel Rate-Full Load ⁽⁴⁾ gal/hr	37.5	31.4

1. Prime kW rating. 1 kW equals 1000 watts. 0.8 power factor.

2. Net flywheel hp rating for fully equipped engine at RPM under SAE J816b.

3. Based on prime HP rating at rated (1800 or 1200) RPM.

4. Based on prime kW rating at rated (1800 or 1200) RPM. Fuel rate may vary depending on operating conditions.

TROUBLESHOOTING

If you cannot correct problems with these procedures see your **Lugger** or **Northern Lights** dealer.

ELECTRICAL

✓ **Battery will not charge**

Loose or corroded connections:

- Clean and tighten battery connections.

Sulfated or worn out batteries:

- Check specific gravity of each battery.
- Check electrolyte level of each battery.

Loose or defective alternator belt:

- Adjust belt tension.
- Replace belt.
- Defective alternator

✓ **Starter inoperative**

Check DC circuit breaker.

Loose or corroded connections:

- Clean and tighten loose battery and harness plug connection.

Low battery output:

- Check specific gravity of each battery.
- Check electrolyte level of each battery.

Defective electrical system ground wire:

- Repair or replace.

✓ **Starter cranks slowly**

Low battery output:

- Batteries too small.
- Battery cables too small.

Check specific gravity of each battery.

Check electrolyte level of each battery.

Crankcase oil too heavy.

Loose or corroded connections:

- Clean and tighten loose connections.

✓ **Entire electrical system does not function**

Check DC circuit breaker.

Faulty connection:

- Clean and tighten battery and harness plug connections.

Sulfated or worn out batteries:

- Check specific gravity and electrolyte level of each battery.

ENGINE

✓ **Engine hard to start or will not start**

Improper starting procedure.

No fuel.

Low battery output:

- Check electrolyte level and specific gravity of battery.

Excessive resistance in starting circuit:

- Clean and tighten all connections on batteries.

Crankcase oil too heavy:

- Use oil of proper viscosity.

Improper type of fuel:

- Consult fuel supplier and use proper type of fuel for operating condition.

Water, dirt or air in fuel system:

- Drain, flush, fill and bleed system.

Clogged primary fuel filter element:

- Clean or replace filter element.

Clogged secondary fuel filter element:

- Replace filter element.

Dirty or faulty injection nozzles:

- Have your dealer check injection nozzles.

Fuel pump primer lever left on upward end of stroke.

✓ **Engine runs irregularly or stalls frequently**

Below normal engine temperature:

- Remove and check thermostat.

Clogged primary fuel filter element:

- Clean or replace filter element.

Clogged secondary fuel filter element:

- Replace secondary filter element.

Water or dirt in the fuel system.

Dirty or faulty injection nozzles:

- Have your dealer check injection nozzles.

Air in fuel system:

- Inspect clamps and hoses on suction side of fuel pump for air leak.

Improper type of fuel:

- Consult fuel supplier and use proper type of fuel for operating condition.

✓ **Lack of engine power**

Engine overloaded:

- Reduce load.

Intake air restriction:

- Service air cleaner.

Clogged primary fuel filter element:

- Clean or replace filter element.

Clogged secondary fuel filter element:

- Replace filter element.

Improper type of fuel:

- Consult fuel supplier and use proper type of fuel for operating conditions.

Overheated engine:

- See "Engine Overheats" in next category.

Below normal engine temperature:

- Remove and check thermostat.

Improper valve clearance:

- See your local dealer.

Dirty or faulty injection nozzles:

- See your local dealer.

TROUBLESHOOTING (CONT.)

If you cannot correct problems with these procedures see your **Lugger** or **Northern Lights** dealer.

✓ **Lack of engine power (cont.)**

Injection pump out of time:

- See your local dealer.

Improper propeller:

- Consult your dealer and prop chart.

Grass, etc. on bottom of boat:

- Clean hull.

Turbocharger malfunction:

- Stop the engine.
- Remove the air cleaner.
- Make sure the compressor wheel is stationary and then rotate it with your hand to see whether it is stiff to rotate.
- First rotate the wheel under light pressure, then by lightly pulling axially. If the wheel is stiff to rotate, blades are damaged or blades hit housing, the turbocharger should be replaced as soon as possible.

✓ **Engine overheats**

Engine overloaded:

- Reduce load (generator sets).
- Check propeller size (propulsion).

Low coolant level:

- Fill tank to proper level.
- Check hoses for loose connections and leaks.

Keel cooling tubes have been painted.

Cooling system needs flushing.

Defective thermostat:

- Remove and check thermostat.

Defective temperature gauge/sender:

- Check water temperature with thermometer and replace gauge or sender if necessary.

Water pump impeller worn/broken (HE Engine).

✓ **Engine knocks**

Insufficient oil:

- Check dipstick
- Call your dealer.

Injection pump out of time:

- Call your dealer.

Below normal engine temperature:

- Check your thermostats.
- Check water temperature to see if temperature gauge is working properly.

Engine overheating:

- See "Engine Overheating" section.

✓ **High fuel consumption**

Improper type of fuel.

Clogged or dirty air cleaner:

- Service air cleaner.

Engine overloaded:

- Reduce load.
- Check proper propeller size.
- Grass, etc. on bottom of boat.

Improper valve clearance:

- See your dealer.

Injection nozzles dirty:

- See your dealer.

Injection pump out of time:

- See your dealer.

Engine not at proper temperature

- Check your thermostats.
- Check water temp. with thermometer to see if temperature gauge is working properly.

✓ **Below normal engine temperature**

Thermostats not working properly:

- Check thermostats.

Temperature gauge not working properly:

- Check water temperature with thermometer.

✓ **Low oil pressure**

Low oil level.

Improper type of oil:

- Drain and fill crankcase with correct oil.

Partially plugged oil filter:

- Replace filter.

✓ **High oil consumption**

Break-in period.

Crankcase oil too light:

- Use proper viscosity oil.

Oil leaks:

- Check for leaks in lines around gaskets and drain plug.

Engine overheats:

- See "Engine Overheats".

✓ **Engine emits black or gray exhaust smoke**

Clogged or dirty air cleaner:

- Service air cleaner.

Defective muffler (back pressure too high).

Improper fuel.

Engine overloaded:

- Reduce load.
- Check propeller size.

Injection nozzles dirty:

- See your dealer.

Engine out of time:

- See your dealer.

✓ **Engine emits white smoke**

Improper fuel.

Cold engine:

- Warm up engine to normal operating temperature.

Defective thermostat:

- Remove and check thermostat.

Engine out of time:

- See your dealer.

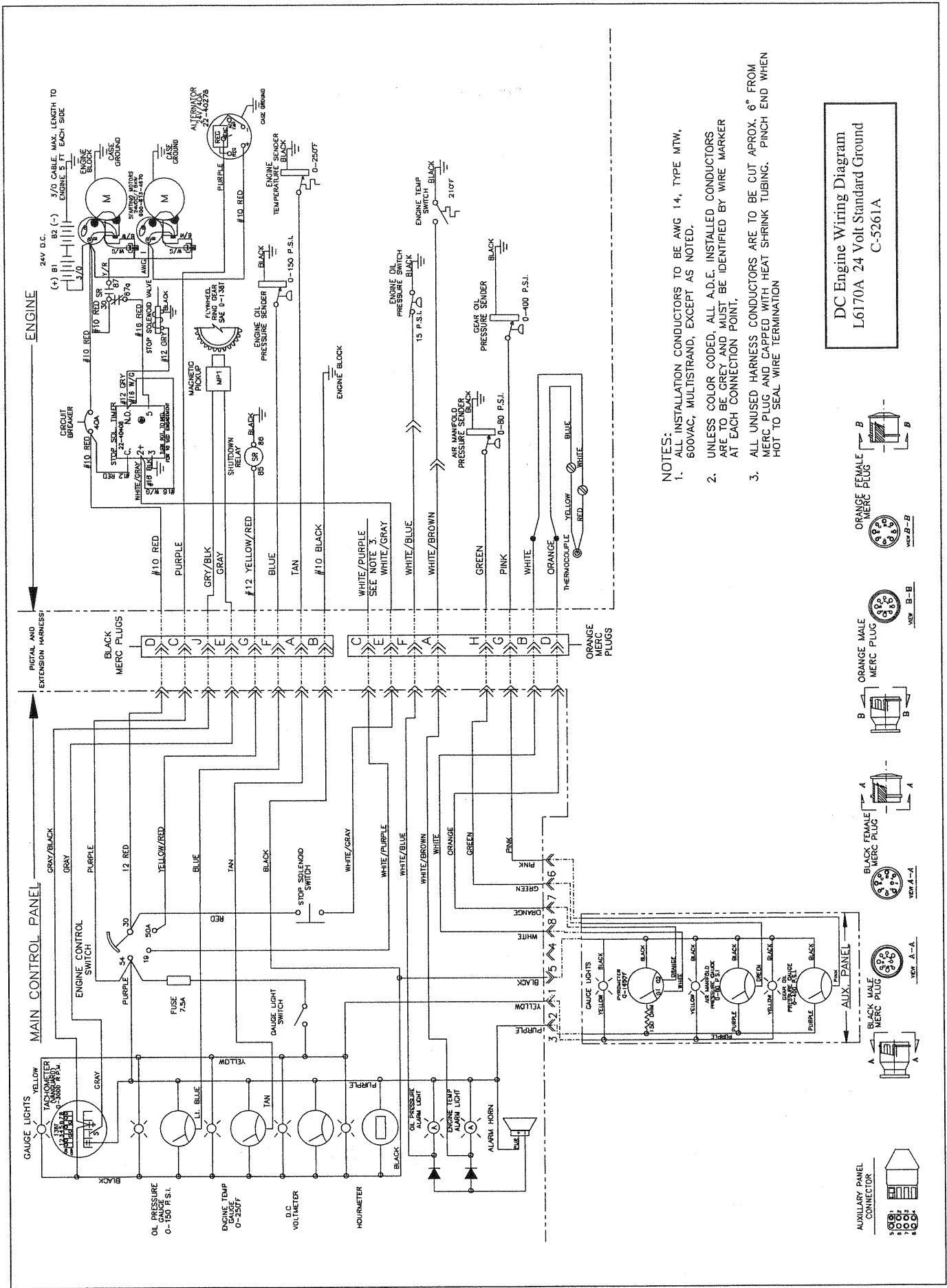

- NOTES:**
1. ALL INSTALLATION CONDUCTORS TO BE AWG 14, TYPE MTW, 600VAC, MULTISTRAND, EXCEPT AS NOTED.
 2. UNLESS COLOR CODED, ALL A.D.E. INSTALLED CONDUCTORS ARE TO BE GREY AND MUST BE IDENTIFIED BY WIRE MARKER AT EACH CONNECTION POINT.
 3. ALL UNUSED HARNESS CONDUCTORS ARE TO BE CUT APPROX. 6" FROM MERC PLUG AND CAPPED WITH HEAT SHRINK TUBING. PINCH END WHEN HOT TO SEAL WIRE TERMINATION

DC Engine Wiring Diagram
L6170A 24 Volt Standard Ground
C-5261A

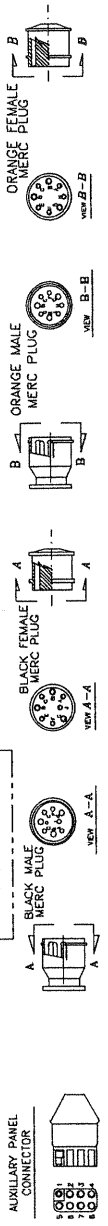

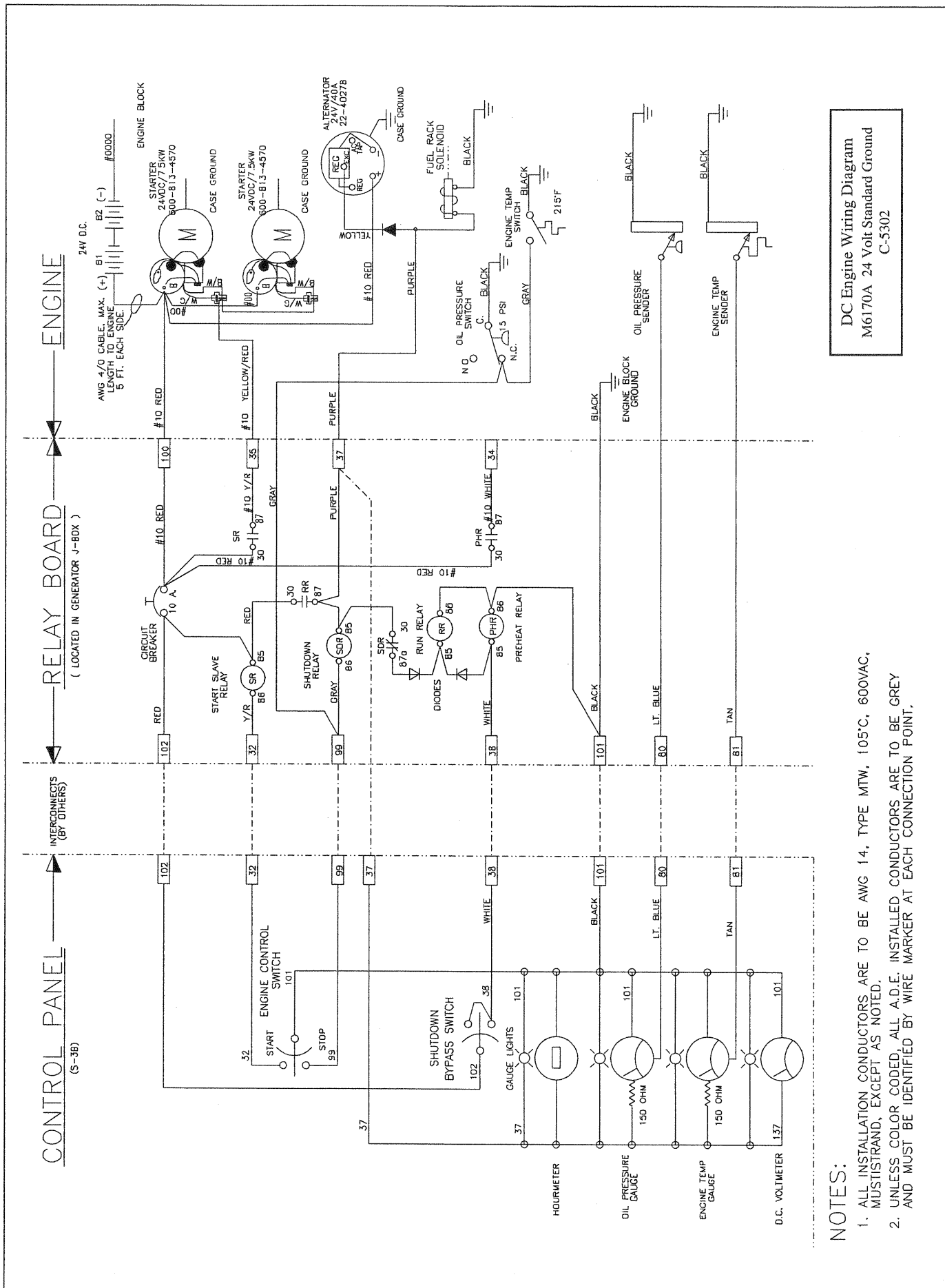

DC Engine Wiring Diagram
M6170A 24 Volt Standard Ground
C-5302

- NOTES:
1. ALL INSTALLATION CONDUCTORS ARE TO BE AWG 14, TYPE MTW, 105°C, 600VAC, MUST ISTRAND, EXCEPT AS NOTED.
 2. UNLESS COLOR CODED, ALL A.D.E. INSTALLED CONDUCTORS ARE TO BE GREY AND MUST BE IDENTIFIED BY WIRE MARKER AT EACH CONNECTION POINT.

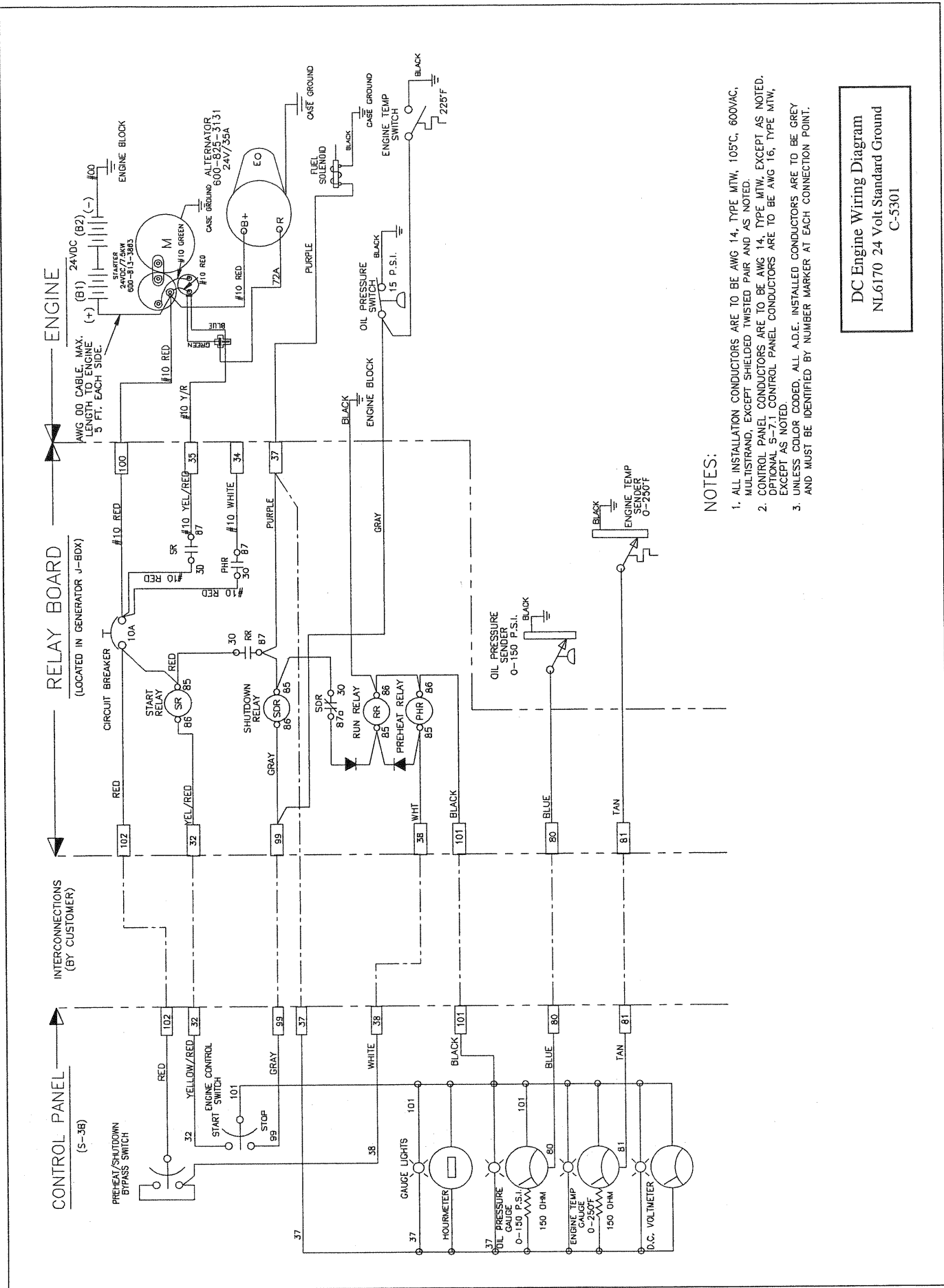

NOTES:

1. ALL INSTALLATION CONDUCTORS ARE TO BE AWG 14, TYPE MTW, 105°C, 600VAC, MULTISTRAND, EXCEPT SHIELDED TWISTED PAIR AND AS NOTED.
2. CONTROL PANEL CONDUCTORS ARE TO BE AWG 14, TYPE MTW, EXCEPT AS NOTED. OPTIONAL 5-7.1 CONTROL PANEL CONDUCTORS ARE TO BE AWG 16, TYPE MTW, EXCEPT AS NOTED.
3. UNLESS COLOR CODED, ALL A.D.F. INSTALLED CONDUCTORS ARE TO BE GREY AND MUST BE IDENTIFIED BY NUMBER MARKER AT EACH CONNECTION POINT.

DC Engine Wiring Diagram
 NL6170 24 Volt Standard Ground
 C-5301

ONBOARD SPARE PARTS

Safety at sea depends on careful preparation, product knowledge, and having the right tools and parts. Below is a list of parts Alaska Diesel Electric, Inc. recommends you carry onboard at all times.

Onboard Parts Kits are available from your dealer. "Standard" Kits are suitable for inland and offshore cruising. "World Class" Kits are for world cruising and trans-ocean cruising.

We consider these minimum quantities. Your vessel's operating conditions may require more of a given part. Consult your dealer.

Item	Description	Standard Quantity	World Class
1	Lube Oil Filter	4	4
2	Air Filter Element	1	1
3	Fuel Filter	2	2
4	Water Filter	2 ◀	2 ◀
5	Injector	0	6
6	O-Ring	0	6
7	O-Ring	0	12
8	Gasket	0	6
9	Thermostat	2	2
10	Thermostat Ring	2	2
11	Relay	0	2
12	Valve Cover Gasket	6	6
13	Alternator Drive Belt	1	2
14	Zinc *	6	12
15	Drive Belt - Raw Water Pump *	0	2
16	Fuel Washer Kit	1	1
17	Workshop Manual	0	1
18	Gasket Kit Top	0	1
19	Gasket Kit Bottom	0	1

* Note: Heat Exchanger cooled engines only.

▶ Note: Double this quantity if engine is keel cooled.

Notes

NORTHERN LIGHTS
4420 14th AVE. N.W.
P.O. BOX 70543
SEATTLE, WA 98107-5043
USA

TEL: (206) 789-3880
FAX: (206) 782-5455
<http://www.northern-lights.com>

