

OL6125
For Model: L6125H

OPERATOR'S MANUAL

Marine Generators | Marine Diesel Engines | Land-Based Generators



LUGGER





— CALIFORNIA —
Proposition 65 Warning:

Diesel engine exhaust and some of its constituents are known to the State of California to cause cancer, birth defects, and other reproductive harm.

Northern Lights
4420 14th Avenue N.W.
Seattle, WA 98107
Tel: (206) 789-3880
Fax: (206) 782-5455

Copyright ©2010 Northern Lights, Inc.
All rights reserved. Northern Lights™, and
the Northern Lights logo are trademarks of
Northern Lights, Inc.

Printed in U.S.A.
PART NO.: OL6125 06/10



OPERATOR'S MANUAL

#OL6125 for Model

L6125H

*Read this operator's manual thoroughly before starting to operate your equipment.
This manual contains information you will need to run and service your new unit.*

Table of Contents

INTRODUCTION	4	Turbo Boost	17
Models Included	4	Linear Erosion	18
Model Numbers	4	Cooling System - General.....	19
Serial Numbers	4	Water Quality	19
WARRANTY	5	Engine Coolant Specifications.....	19
SAFETY RULES	5	Supplemental Cooling Additive.....	20
COMPONENT LOCATIONS		Coolant Testing	20
L6125H	6	Checking Coolant Level	20
Control Panels.....	7 - 9	Cooling System Flushing.....	21
OPERATING PROCEDURES		Heat Exchanger Cleaning	21
Before Starting.....	10	Zinc Electrodes	21
Shutdown Procedures	10	Raw Water Pump	21
Alarms.....	11	Driven Equipment.....	22
Break-In Period.....	11	Electrical System - General	22
SERVICING SCHEDULE CHART	12	Welding and ECU Precautions	22
SERVICE RECORD	13	Booster Batteries.....	22
SERVICING		Battery Care	22
Lubrication - General.....	14	Winterizing / Out-of-Service	23
Checking Oil.....	14	TROUBLESHOOTING	
Oil Changes	14	Engine	24 - 25
Changing Oil Filter	14	DIAGNOSTIC TROUBLE CODES	26 - 27
Air Filter/Crankcase Breather.....	14	DATA SHEETS	
Air Filter Service	15	Unit Specifications.....	28
Valve Clearances.....	16	ON-BOARD SPARE PARTS	29
Fuels - General.....	16	WIRING DIAGRAMS	30
Crankshaft Damper.....	16	NOTES (Blank)	31 - 32
Fuel Filters	16		
Bleeding the Fuel System	17		
Turbocharger.....	18		

Proprietary Information

This publication is the property of Northern Lights, Inc.

It may not be reproduced in whole or in part without the written permission of Northern Lights, Inc.

© Northern Lights, Inc. All rights reserved. Litho U.S.A. Publication number OL6125 06/10

Introduction

Servicing of marine engines presents unique problems. In many cases boats cannot be moved to a repair facility. Marine engines cannot be compared to the servicing of automobiles, trucks or even farm equipment. Failures often occur in remote areas far from competent assistance. Marine engines are taxed far more severely than auto or truck engines; therefore, maintenance schedules must be adhered to more strictly.

Failures begin with minor problems that are overlooked and become amplified when not corrected during routine maintenance.

As operator, it is your obligation to learn about your equipment and its proper maintenance. This is not a comprehensive technical service manual. Nor will it make the reader into an expert mechanic. Its aim is to aid you in maintaining your unit properly.

Model Numbers

Model numbers give the unit's application, block model, and aspiration:

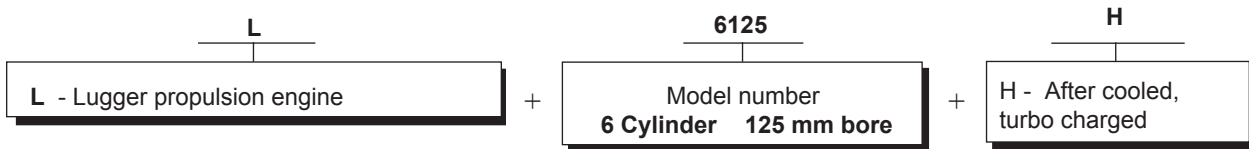

L6125H = Lugger® turbocharged propulsion engine with a John Deere engine block, aftercooled, Tier II.

Serial Numbers

When referencing Northern Lights, Inc. equipment by serial number, please refer only to the number stamped on the Northern Lights® or Lugger® serial number plate.

The image shows a rectangular serial number plate with a decorative border. At the top, the word 'LUGGER' is written in large, bold, italicized letters, with 'by NORTHERN LIGHTS' in smaller, bold, italicized letters below it. There are two horizontal input fields: the top one is labeled 'Serial No.' and the bottom one is labeled 'Model No.'. At the bottom of the plate, the company name 'Northern Lights' and address '4420 - 14th Ave. NW Seattle, WA 98107' are printed.

A warranty registration certificate is supplied with your set. The extent of coverage is described in the Limited Warranty Statement. We recommend that you study the statement carefully.

NOTE: If the warranty is to apply, the servicing instructions outlined in this manual must be followed. If further information is needed, please contact an authorized dealer or the factory..

Safety Rules



CAUTION: *Accident reports show that careless use of engines causes a high percentage of accidents. You can avoid accidents by observing these safety rules. Study these rules carefully and enforce them on the job.*

- Never leave engine without proper security.
- Turn the coolant tank cap slowly to relieve pressure before removing. Add coolant only when the engine is stopped and cool.
- Mount a fire extinguisher near engine.
- Always disconnect the battery ground strap before making adjustments.
- Operate engines in properly ventilated areas.
- Keep trash and other objects away from engine.
- Escaping fluids under pressure can penetrate your skin. Use a piece of cardboard or wood, not your hands, to search for leaks.
- Avoid wearing loose clothing when working around engines.
- Do not oil or grease engine while it is running.
- Use caution in handling fuel. Never refuel a hot or running engine. Do not smoke while filling fuel tank or servicing fuel system.
- Keep your hands, feet, hair and clothing away from power-driven parts.
- Check for any loose electrical connections or faulty wiring.
- Engines should be operated only by knowledgeable, qualified personnel.
- Look completely around engine to make sure that everything is clear before starting.
- Do not operate an engine that isn't in proper working order. If an unsafe operating condition is noted, tag the set and control panel so others will also know about the problem.
- Provide first aid kits.

CALIFORNIA Proposition 65 Warning:

Diesel engine exhaust and some of its constituents are known to the State of California to cause cancer, birth defects, and other reproductive harm.



CAUTION: *This symbol is used throughout this book to alert you to possible danger areas. Please take special notice of these sections.*

L6125H Component Locations

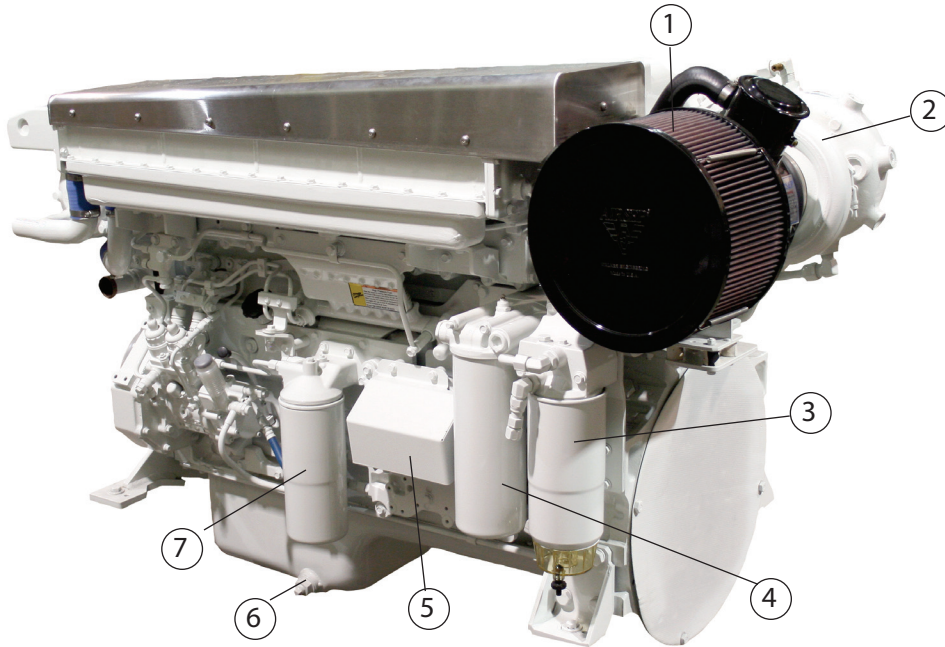
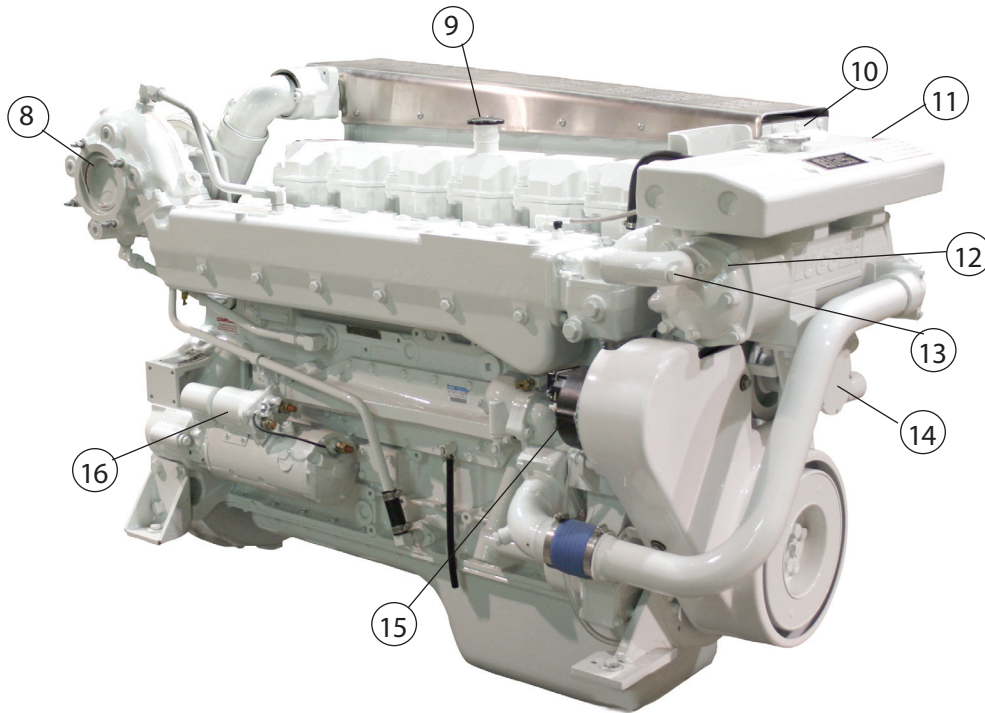

Figure 1a: L6125H



- | | |
|------------------------------------|--------------------------------|
| 1. Air filter / crankcase breather | 8. Turbo outlet |
| 2. Turbocharger | 9. Lube oil fill |
| 3. Primary fuel filter | 10. Water fill |
| 4. Spin on oil filter | 11. Expansion tank |
| 5. Electronic Control Unit | 12. Heat exchanger |
| 6. Lube oil drain | 13. Heat exchanger zinc anodes |
| 7. Final fuel filter | 14. Raw water pump |
| | 15. DC alternator |
| | 16. Starter |



Figure 1b: L6125H

1. TACHOMETER

Shows engine speed in revolutions per minute (RPM). Numbers are multiples of 100.

2. HOUR METER

Tracks engine running time.

3. DC VOLTMETER

When engine is stopped, shows condition of battery.
When engine is running, shows voltage output of alternator.

4. KEY SWITCH

Turn key clockwise to first position to switch current on. Continue turning clockwise to start the engine. When the engine starts, immediately turn the key back to the first position while the engine is running. The key must be kept in the first or on position while the engine is running. Turn the key counterclockwise until it stops to stop the engine.

Note: Optional flybridge panels have engine start switches instead of keys switches (see page 8).

5. POTENTIOMETER

Dims panel lights.

6. ALARM HORN

If alarm sounds, shut down engine if possible and investigate immediately.

7. COOLANT TEMPERATURE GAUGE

Shows temperature of cooling water. If the gauge registers above 200° F, or below 140° F, stop the engine and investigate.

8. OIL PRESSURE GAUGE

Shows oil pressure in the engine lubricating system. If the pressure drops below 15 PSI at a speed higher than idling, stop the engine immediately.

PowerView Control Panel



POWERVIEW CONTROL PANEL

1. Amber Warning LED
2. Red Shutdown Derate LED
3. Enter key
4. Right arrow key (scroll down)
5. Left arrow key (scroll up)
6. Menu key
7. Menu

For a full description and operator's instruction of the PowerView control panel, please consult Murphy publication OPV-02121N

NOTE: The control panels shown on this page are optional. Your L6125H may or may not be equipped with these options.

FLYBRIDGE PANEL

1. TACHOMETER

Shows engine speed in revolutions per minute (RPM). Numbers are multiples of 100.

2. START BUTTON

Hold down to start engine.

3. STOP BUTTON

Hold down to stop engine.

4. ALARM HORN

If alarm sounds, shut down engine if possible and investigate immediately.

5. COOLANT TEMPERATURE GAUGE

Shows temperature of cooling water. If the gauge registers above 200° F, or below 140° F, stop the engine and investigate.

6. OIL PRESSURE GAUGE

Shows oil pressure in the engine lubricating system. If the pressure drops below 15 PSI at a speed higher than idling, stop the engine immediately.



Figure 1c: Flybridge panel

AUXILIARY PANEL

7. PYROMETER

Shows engine exhaust temperature.

8. BOOST GAUGE

Shows status of turbobooster

9. GEAR OIL PRESSURE

Shows oil pressure of transmission.



Figure 1d: Auxiliary panel

Operating Procedures

BEFORE STARTING

1. Check the water level by removing the pressure cap from the expansion tank. In order to give the cooling water room to expand, the level should be about 1 3/4 in. (4-5 cm) below the filler cap sealing surface when the engine is cold. When filling with coolant, the venting cock on top of the turbocharger should be opened to ensure that no air pockets form in the cooling system (**see Service Point #14**).



CAUTION: Use protective clothing and open the filler cap carefully when the engine is warm to prevent burns.

2. Check the oil level in the crankcase with the dipstick. The oil level should be between the “waffled area” and the “Add”. Never allow the level to go below the “Add”. Do not fill above the crosshatch pattern. Oil levels within the crosshatch are considered in the acceptable operating range. Always add the same viscosity of oil as is already in the crankcase (**see Service Point #1**).
3. Check the fuel tank level and open any fuel valves. Check for leakage from fuel line. Check that there is no leakage of fuel or damage to the hoses and tubes. If any problem is found, carry out repairs.
4. Check the oil level in the reverse gear. Methods may vary from gear to gear. See your Gear Owner's Manual. Check transmission and gear oil collar for oil leakage from hydraulic hoses and joints. If any problem is found, repair the area where oil is leaking.
5. Close the seacock, check and clean the strainer and reopen the seacock.
6. Place the battery switch in the ON position.

NOTE: The battery switch must always be kept ON while the engine is running. If the switch is turned OFF while the engine is running, the battery charging regulator could be ruined.

Starting

1. Put the gear control in the neutral position.
2. Move the throttle control to the idle position.
3. Turn the key switch to the first position. Check the voltage meter to see the condition of the batteries. For starting, the voltmeter should not read below 24 volts.
4. Turn the key to the starting position and as soon as the engine starts, release the key. Move the throttle up until the engine is running at approximately 1000 RPM.

5. Do not crank the starter for more than 15 seconds consecutively. If the engine fails to start with the first attempt, be sure that the starter has stopped completely before re-engaging.

NOTE: Never race a cold engine. Operate at 1000 RPM for a 3 to 5 minute warm-up period.

Operating

1. Check oil pressure as soon as the engine has started. Oil pressure should be above 15 PSI. The engine must never be run if the oil pressure is below 15 PSI.
2. Check the voltmeter. It should read 26-28 volts at 60°F (16°C).
3. Water temperature should not rise over 200°F (94°C). If it does, shut down the engine and investigate the cause of overheating.
4. Do not exceed 800 RPM when shifting marine gear. Repeated shifts at higher engine speeds can damage the reverse gear.
5. Low idle is 650 RPM. Maximum working engine speed is: 2100 RPM for High Output, 1900 RPM for Medium Duty, and 1800 RPM for Continuous Duty.
6. If the proper propeller is used, the engine should reach its appropriate maximum RPMs at full throttle. If the maximum rated RPMs for your engine application is exceeded at full throttle, then your propeller is too small. If you cannot reach your maximum rated RPMs at full throttle, either your propeller is too large or bottom growth is slowing the boat.
7. To establish Maximum Cruising RPM: Establish the RPM at full throttle and subtract 200-300 RPM. This will promote engine life and reduce fuel consumption.

SHUTDOWN

1. Run engine three to five minutes in neutral at 1000 RPM, for cool down period.
2. Return engine to low idle.
3. Turn the key switch counterclockwise as far as possible to stop the engine.
4. Close the sea cock and fuel valves and put the battery switch in OFF position.



NOTE: Do not turn the battery switch to OFF while the engine is running.

ALARMS

1. Your unit is fitted with a warning system to indicate high water temperature or low oil pressure.

Propulsion engines have warning horns to sound and warn you of a problem. Remember- when the engine is not running the horn will sound when the key is in the "ON" position because there is no oil pressure.



NOTE: *Do not rely on your warning or shutdown system to the exclusion of careful gauge monitoring. Watching your gauges can prevent damage to the unit and dangerous power losses.*

2. Do the following when your shutdown system is activated:
 - a. Check the temperature gauge. If the temperature is above 205°F (97°C), shut off the engine immediately.
 - b. Use the Trouble Shooting Guide on pages 18- 19 to isolate the cause of the overheat.



CAUTION: *Do not remove the water fill cap of an overheated engine. Escaping high temperature steam can cause severe burns. Allow the engine to cool and then remove the cap slowly, using protective clothing.*

- c. Make repairs and restart after the temperature gauge registers below 180°F (83°C).
 - d. Watch the temperature gauge regularly and turn off the unit if the temperature rises above 200°F (94°C). Repeat the troubleshooting process.
3. If the shutdown is activated and the temperature gauge shows temperature within normal temperature range:
 - a. Check the engine crankcase oil level.
 - b. If the oil level is low, fill with recommended lubricating oil and restart. Watch the oil pressure gauge carefully and shut off the engine if it does not show a normal reading after a few seconds of operation.
 - c. If the oil level is normal, DO NOT restart the engine. Call your Northern Lights or Lugger dealer for assistance.

BREAK-IN PERIOD

1. Your engine is ready to be put into service. However, the first 100 hours on a new or reconditioned engine are critical to its life and performance.
2. Operate with an average of 75% load on your engine for the first 100 hours. Maintain no less than a 50% load to ensure proper seating of the piston rings.
3. Oil consumption is greater during break-in as piston rings take time to seat.
4. Your engine comes equipped with break-in oil. Change engine oil and filter at 50 hours using API Service Category CC, CD, or CE break-in oil. Change the oil and filter again at 100 hours. (Consult the lubricants section for oil recommendation.)
5. Frequently check the engine temperature and oil pressure gauges.

Servicing Schedule Chart

The Servicing Schedule Chart below shows the service schedule required for proper maintenance of your marine engine or generator set. More detailed coverage of each Service Point (SP) is listed on the page noted in the 'page' column.

DAILY:

- SP1 Check oil level in engine
- SP7 Check primary fuel filter
- SP14 Check cooling water level
- SP24 Check sea water strainer

AFTER FIRST 50 HOURS:

- SP2 Change engine oil
- SP3 Change lube oil filter

EVERY 50 HOURS:

- SP20 Check electrolyte in batteries

FIRST 100 HOURS:

- SP2 Change engine oil
- SP3 Change lube oil filter

EVERY 250 HOURS:

- SP2 Change engine oil
- SP3 Change lube oil filter
- SP4 Check air cleaner
- SP8 Change primary fuel filter element

- SP12 Check turbocharger air, oil & cooling lines for leakage
- SP18 Check zinc electrodes

EVERY 600 HOURS / YEARLY:

- SP4 Replace air cleaner
- SP5 Check V-belt condition
- SP9 Change secondary fuel filter
- SP10 Check injectors
- SP13 Check turbocharger boost pressure
- SP15 Check and flush cooling system
- SP19 Change impeller in raw water pump
- SP21 Check the state of the charge of the batteries

EVERY 2500 HOURS:

- SP6 Check valve clearances
- SP16 Check and clean heat exchanger
- SP17 Check and clean gear oil cooler
- SP23 Check crankshaft damper

SERVICE POINT	PAGE	OPERATION	DAILY	50 Hours	250 Hours	600 Hours	2500 Hours
ENGINE:							
SP1	10	Check oil level	•				
SP2	10	Change engine oil 1)			•		
SP3	10	Change lube oil filters 1)			•		
SP4	10	Check (replace) air cleaner 1) 3)			•	•	
SP5		Check belt condition 1)				•	
SP6	11	Check valve clearances 1)					•
SP23	11	Check crankshaft damper 4)					•
FUEL SYSTEM:							
SP7	12	Check primary filter 2)	•				
SP8	12	Change primary filter element 2) 3)			•		
SP9	12	Change secondary fuel filter 1) 3)				•	
SP10		Check injectors 5) 6)					
TURBOCHARGER:							
SP12	13	Check air, oil & cooling water lines for leakage 1)			•		
SP13	13	Check boost pressure				•	
COOLING SYSTEM:							
SP14	15	Check cooling water level	•				
SP15	15	Check and flush cooling system 1)				•	
SP16	15	Check and clean heat exchanger 1)					•
SP17		Check and clean gear oil cooler 1)					•
SP18	15-16	Check zinc electrodes 1) 3)			•		
SP19	16	Change impeller in raw water pump 1) 3)				•	
SP24		Check sea water strainer	•				
ELECTRICAL SYSTEM:							
SP20	17	Check electrolyte level in batteries 1) 3)		•			
SP21	17	Check condition of batteries with hydrometer 1)				•	
OUT OF SERVICE:							
SP22	17	Winterizing or out-of-service 3)					

1) Perform all maintenance once a year even if hour level has not been reached. 5) At 2500 hrs. an electronic injector preload adjustment must be made.
 2) Consult manufacturer's maintenance schedule, note on chart. 6) Check at 5000 hours.
 3) Whenever necessary.
 4) Replace crankshaft damper @ 4500 hrs. or 60 mos., which ever occurs first.

Service Record

Service Point	OPERATION	HOURS/DATE									
50 HOURS											
SP20	Check electrolyte										
	in batteries										
250 HOURS											
SP2	Change engine oil										
SP3	Change lubricating oil filters										
SP4	Check air cleaner										
SP7	Change primary fuel filter element										
SP12	Check turbocharger air, oil & cooling lines for leakage										
SP18	Check zinc electrodes										
600 HOURS											
SP4	Replace air cleaner										
SP5	Check belt condition										
SP9	Change secondary fuel filter										
SP13	Check turbocharger boost pressure										
SP15	Check and flush cooling system										
SP19	Change impeller in raw water pump										
SP21	Check state of charge of batteries										
2500 HOURS											
SP6	Check valve clearances										
SP16	Check and clean heat exchanger										
SP17	Check and clean reverse gear oil cooler										
SP23	Check crankshaft damper										

Serviceing

LUBRICATION

Break-in oil

1. Use one of the following during the first 100 hours of operation:
 - a. John Deere Engine Break-In Oil
 - b. API Service CC, CD oil
 - c. ACEA Specification E1
2. *Do not use* John Deere PLUS-50 oil or engine oils meeting API CF-4, API CG-4, API CH-4, API CI-4, ACEA E2, ACEA E3, ACEA E4, or ACEA E5 performance levels during the first 100 hours of operation of a new or rebuilt engine. These oils will not allow the engine to break-in properly.

Lubrication - General

1. Use only clean, high quality lubricants stored in clean containers in a protected area.
2. These oils are acceptable after the first 100 hours:
 - a. API Service CH-4, CJ-4 multi-viscosity oils.
 - b. API Service CD/CG-4/CF-4 multi-viscosity oils.
 - c. ACEA Specification E3
 - d. ACEA Specification E4/ E5
3. Use the proper weight oil for your average operation temperature.

Air Temperature	Single Viscosity	Multi Viscosity
Above 32°F (0°C)	SAE-30W	SAE15-40W
-10°F to 32°F (-23°C to 0°C)	SAE-10W	SAE10-30W
Below -10°F (-23°C)	SAE-5W	SAE5-20W

4. Some increase in oil consumption may be expected when SAE 5W and SAE 5-20W oils are used. Check oil level frequently.
5. Never put additives or flushing oil in crankcase.

SP1. CHECK ENGINE OIL LEVEL

1. Check the oil level in the crankcase, with the oil dipstick, daily.
2. The oil level must be between the “Waffled area” and the “Add”. Never allow the level to go below the “Add”.
3. Always add the same viscosity of oil as is already in the crankcase.

SP2. OIL CHANGES

1. Using the oil recommended above, change the engine oil and filter after the first 100 hours of operation, and every 250 hours thereafter.
2. During intermittent cold weather operation, change oil every 100 hours or six weeks, whichever comes first.
3. Change oil at any seasonal change in temperature when a new viscosity of oil is required.
4. Engine Lube Oil Capacity:

6125	34.0 qts.	32 liters
------	-----------	-----------

SP3. CHANGING OIL FILTER

1. Change the lube oil filter every 250 hours.
2. Use a filter wrench to remove old filter. Dispose of filter in approved manner.
3. Make sure the gasket from the old filter is removed and discarded.
4. Lubricate the rubber gasket on the new filter and screw it on nipple until gasket meet the sealing surface.
5. Using hands only, no wrench, tighten filter one-half turn farther. Overtightening can do damage to filter housing.
6. Fill engine with recommended oil. Start engine and check for leakage. Stop engine and check oil level. Add additional oil if necessary.

SP4. AIR FILTER/CRANKCASE BREATHER

1. Inspect air cleaner every 100 hours, clean and re-oil every 600 hours, or yearly, or when red service light is visible in air filter restriction indicator; whichever comes first. Replace filter element after 5 to 7 cleaning cycles, depending on condition.
Note: Use part # 24-20019 Cleaning and Re-Oiling Kit, do not use motor oil or other oils to re-oil filter.
2. Replace oil separator filter every 600 hours, or yearly, or if oil leakage is seen at crankcase pressure regulator vent; whichever comes first. *Note: Air filter element must be removed to access retaining clamp and cover that retains oil separator filter inside.*
3. Check hoses and clamps on crankcase pressure regulator plumbing for tightness, chafing or deterioration.
4. Start the engine and check for leaks.

NOTE: Make absolutely sure no impurities enter the engine while changing the element. Do not run

AIR FILTER SERVICE PROCEDURE

1 - Remove v-band clamp or retaining springs and air filter.

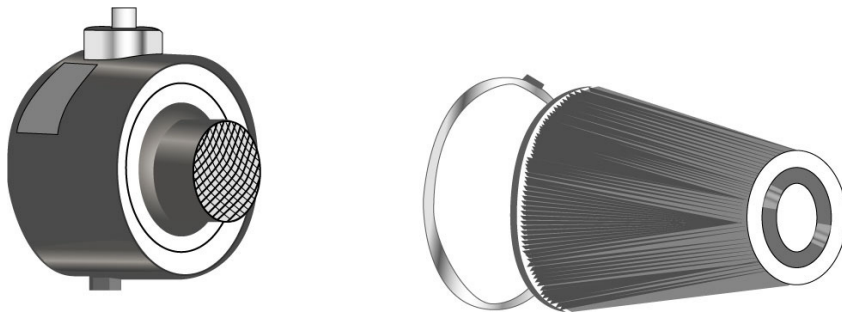

2- Carefully remove silencer lid and o-rings.

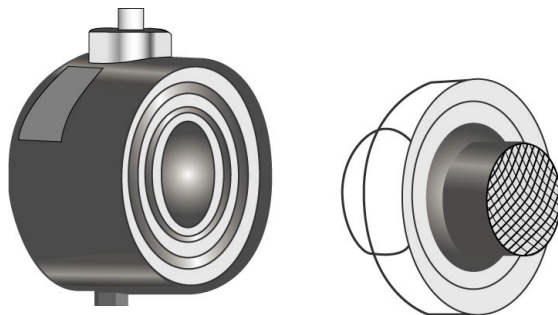

3 - Carefully raise service handle on oil separator element.
Pull out of housing with equal force.

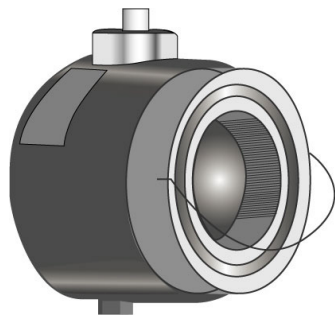

4 - Once oil separator element is removed, reach inside housing and pull first element stage down. (Discard both elements and replace with new.) Reassemble by placing o-rings, silencer lid, v-band or retaining springs and air filter back into place.

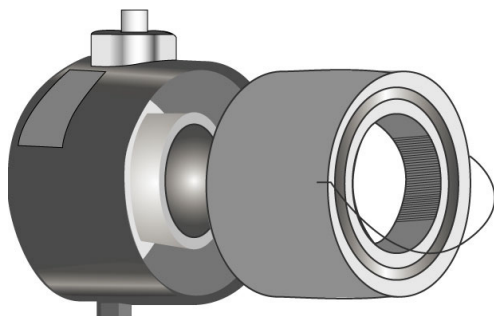

IMPORTANT - Drainage window *must* be positioned at bottom of primary element or system will malfunction. *Both* first stage and coalescing elements must be replaced at the same time.

SP6. VALVE CLEARANCES & ELECTRONIC UNIT INJECTOR PRELOAD

1. Have your dealer adjust intake and exhaust valve clearance and electronic unit injector (EUI) preload. This one-time adjustment for all new and overhauled engines is required after the first 2500 hours of operation.

FUELS - GENERAL

1. Use only clean, high quality fuels of the following specifications, as defined by ASTM designation D975 for diesel fuels:
 - a. Use grade no. 2 diesel at ambient temperatures above freezing 30°F (0°C).
 - b. Use grade No.1 at ambient temperatures below freezing and for all temperatures at an altitude of above 5,500 ft. (1500 meters).
2. Sulphur content should not exceed 0.5% (preferably less than 0.5%).
3. The cetane number should be a minimum of 45.
4. DO NOT use these unsuitable grades of fuel:
 - a. Domestic heating oils, all types.
 - b. Class B engine.
 - c. Class D domestic fuels.
 - d. Class E, F, G or H industrial or marine fuels.
 - e. ASTM-D975-60T No. 4-D and higher number fuels.
 - f. JP4
5. Storing fuel:
 - a. Keep dirt, scale, water and other foreign matter out of fuel.
 - b. Avoid storing fuel for long periods of time.
 - c. Fill the fuel tank at the end of each day's operation. This will reduce condensation.

SP23. CHECK CRANKSHAFT DAMPER

1. Remove belt.
2. Carefully inspect the vibration damper for torn or split rubber protruding from the front or back of assembly.
3. Grasp vibration damper with both hands and attempt to turn it in both directions. If rotation can be felt, the damper is defective and should be replaced.

Note: The vibration damper assembly is not repairable and should be replaced every 4500 hours or 60 months, whichever occurs first.

Always replace the vibration damper whenever the crankshaft is replaced or a major engine overhaul takes place.

SP7-9. FUEL FILTERS

1. Your engine will have a primary and final fuel filter installed. We also recommend the addition of Racor brand of fuel filter - water separators.
 - a. Check the primary fuel filter daily as recommended by the filter manufacturer. Empty the collection bowl as necessary.
 - b. Change the primary element every 250 hours or whenever necessary.
 - c. If the bowl fills with water, change the primary and secondary elements immediately.
2. Change secondary fuel filter every 500 hours or annually.

NOTE: *The fuel filter on the engine is considered the "secondary fuel filter".*

 - a. Turn off the fuel.
 - b. Be sure area around fuel filter assembly is clean.

3. Check for water and sediment in primary fuel filter/ water separator. (Figure 2)
 - a. The water separator forms one unit with the primary fuel filter (1)
 - b. It is possible to judge the water level and amount of sediment by looking through the transparent cap (2). If there is any water or sediment collected at the bottom, set a container to catch the drain water under drain valve (3).
 - c. Loosen drain valve and drain the water.
 - d. When fuel starts to drain, tighten drain valve (4) immediately. Tightening torque: 0.2 to 0.45 Nm (0.02 to 0.046 kgm, 0.1 to 0.3 lbft.).

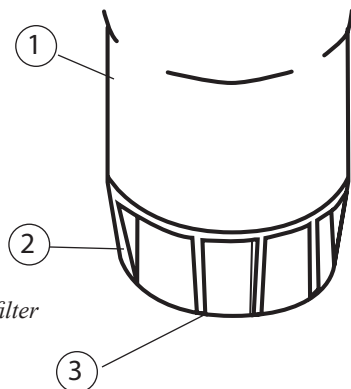

Figure 2: Secondary Fuel filter

BLEEDING THE FUEL SYSTEM



CAUTION: Escaping diesel fuel under pressure can penetrate the skin, causing serious personal injury. Relieve pressure before disconnecting fuel or other lines. Tighten all connections before applying pressure. Keep hands and body away from pinholes and nozzles which eject fluids under high pressure. Use a piece of cardboard or paper to search for leaks. **DO NOT USE YOUR HAND.**

If ANY fluid is injected into the skin, it must be surgically removed within a few hours by doctor familiar with this type of injury or gangrene may result. Doctors unfamiliar with this type of machinery may call the Deere and Company Medical Department in Moline, Illinois, or other knowledgeable medical source.

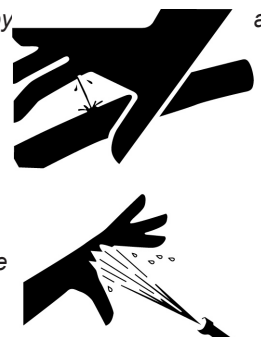

CAUTION: Due to High Pressure

Common Rail system design, fuel in filter is likely to be under high pressure. To avoid possible personal harm, open valve (C) on bottom of water separator bowl to relieve the pressure prior to removing each filter.

1. Normally it is not necessary to bleed the fuel system - using the hand primer is usually sufficient. But if the engine has run out of fuel or the fuel system was full of air, use special tool #53-50005 to quickly prime and bleed the fuel system.

Note: If tool is not available, loosen diagnostic connector on filter housing until air and fuel can escape.

 - a. To bleed the fuel system, open the drain valve (Figure 2-A) on the fuel filter and use hand primer to drain water and contaminants.
 - b. Attach an open line to the diagnostic port above the hand primer and put the end of the line in a container for diesel fuel using tool #53-50005.
 - c. Pump the hand primer until a steady flow of fuel without bubbles comes out.
 - d. Disconnect the line from the diagnostic port.
 - e. Close the return line.
 - f. Pump primer until firm.
 - g. Crank the engine until it starts (15 seconds maximum, 60 seconds rest).
 - h. Open return line.

SP12. TURBOCHARGER

1. Check for air leaks every 250 hours. Air leakage will lower engine output and may cause black exhaust smoke and soot.
2. Listen along air line while engine is running. A whistling or hissing sound indicates leakage.
3. Leakage on the pressure side, between turbo and engine, can be found by applying soapy water to the air line.
4. Tighten the hose clamps, replace hose or gaskets as required.
5. Check to see that the lubrication and cooling lines are tight and without leaks.

SP13. TURBO BOOST

1. This check measures the amount of air the turbo is pushing into the engine. It should be done by an authorized dealer every 600 hours.
2. On the inlet manifold there is a 1/8" NPT threaded port. Remove the plug and install the boost gauge hose. Refer to your engine specifications for correct pressure.

LINER EROSION (PITTING)

1. Cylinder liner walls (Figure 3-A) which are in contact with engine coolant (Figure 3-B) can be eroded or pitted unless the proper concentration and type of SCA's are present in the coolant. Water pump impellers are also susceptible to pitting.
2. Vapor bubbles (Figure 3-C) are formed when the piston's impact causes the liner walls to vibrate, sending pressure waves into the coolant.
3. These tiny vapor bubbles collect on the surface of metal parts. As the bubbles collapse (pop) a microscopic piece of metal is eroded from the metal part. Over a period of time, this pitting may progress completely through the cylinder liner of a wet-sleeve, heavy-duty diesel engine. This allows engine coolant to enter the combustion chamber. Engine failure or other serious damage will result.

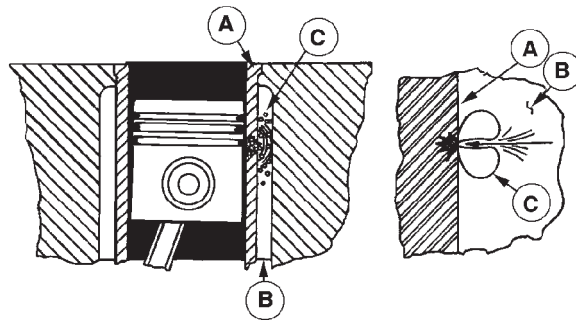

A - Cylinder Liner Walls B - Engine Coolant C - Vapor Bubbles

Figure 3.

4. Unprotected engines with low quality water as coolant can have liner failure in as few as 500 hours.

COOLING REQUIREMENTS

1. To meet cooling system protection requirements, the coolant solution must consist of:
 - a. **Quality water**
 - b. **Ethylene glycol concentrate (EGC) commonly known as antifreeze.**
 - c. **Supplemental coolant additives (SCA's).**
2. A coolant solution of ethylene glycol concentrate (EGC-antifreeze), quality water and supplemental coolant additives (SCA's) **MUST** be used **YEAR ROUND** to protect against freezing, boil-over, liner erosion or pitting and to provide a stable, noncorrosive environment for cooling system components.
3. **Ethylene glycol coolant concentrate (antifreeze) normally DOES NOT contain the SCA chemical inhibitors needed to control liner pitting or erosion, rust, scale, and acidity.**

Contaminates	Parts per Million	Grains per Gallon
Maximum Chlorides	40	2.5
Maximum Sulfates	100	5.9
Maximum Dissolved Solids	340	20.0
Maximum Total Hardness	170	10.0
PH Level 5.5 to 9.0		

WATER QUALITY

1. Distilled, deionized, soft water is preferred for use in cooling systems. Bottled distilled water from a food store or water supplier is recommended. Tap water often has a high mineral content. Tap water should NEVER be put in a cooling system unless first tested by a water quality laboratory. Do not use water made by the reverse osmosis method unless it has been PH neutralized.
2. Here are acceptable water quality specifications:

	Distilled Water %	EGC % Antifreeze	Freeze Point	Boiling Point
Optimum	50%	50%	-37°C -34°F	+109°C +226°F
Minimum	60%	40%	-24°C -12°F	+106°C +222°F
Maximum	40%	60%	-52°C -62°F	+111°C +232°F

3. If chlorides, sulfates or total dissolved solids are higher than the above given specification, the water must be distilled, demineralized, or deionized before it is used in a cooling system.
4. If total hardness is higher than 170 ppm and all other parameters are within the given specifications, the water must be softened before it is used to make coolant solution.

EGC: ETHYLENE GLYCOL CONCENTRATE (ANTIFREEZE)



CAUTION: EGC (Antifreeze) is flammable.

Keep it away from any open flame. Avoid contact with eyes. Avoid contact with skin. Do not take internally. In case of contact, immediately wash skin with soap and water. For eyes, flush with large amounts of water for at least 15 minutes. Call a physician. **KEEP OUT OF REACH OF CHILDREN.** Follow all warnings on the container.

1. Ethylene glycol coolant concentrate is commonly mixed with water to produce an engine coolant with a low freeze point and high boiling point.
2. A **low silicate** form of ethylene glycol coolant is recommended for all diesel engines.
3. Use an ethylene glycol coolant concentrate meeting ASTM D 6210, D4985P, and D5345.
4. This product is concentrated and should be mixed to the following specification.
5. If additional coolant solution needs to be added to the engine due to leaks or loss, the glycol concentration should be checked with a hydrometer to assure that the desired freeze point is maintained.

IMPORTANT

1. **DO NOT** use methyl alcohol or methoxy propanol base EGC. These concentrates are not compatible with chemicals used in supplemental coolant additives. Damage can occur to rubber seals on cylinder liners which are in contact with coolant.
2. **DO NOT** use an EGC containing sealer or stop-leak additives.
3. **DO NOT** use EGC containing more than 0.1% anhydrous metasilicate. This type of concentrate, which is intended for use in aluminum engines, may cause a gel-like deposit to form that reduces heat transfer and coolant flow. Check container label or consult with supplier.

SUPPLEMENTAL COOLANT ADDITIVE (SCA)



CAUTION: Supplemental coolant additive contains alkali. Avoid contact with eyes. Avoid contact with skin. Do not take internally. In case of contact immediately wash skin with soap and water. For eyes, flush with large amounts of water for at least 15 minutes. Call a physician. **KEEP OUT OF REACH OF CHILDREN.** Follow all warnings on the container.

1. **Important heat exchanger cooled engines**
Additional SCA's should NOT be added to the mixture of EGC/H₂O on initial fill up of engines with a coolant conditioner-filter. A high SCA concentration will result and can cause silicate-dropout. When this happens, a gel-type deposit is created in the cooling system which retards heat transfer and coolant flow.
2. If additional SCA's are needed, prepare a mixture of 50% quality water and 50%EGC (antifreeze). Add liquid SCA at a rate of 3%, by volume.
Example: 30 mL of SCA per liter of H₂O/EGC mixture (1.0 fl oz of SCA per qt of H₂O/EGC). Add the resulting mixture to the cooling system in quart increments. Run the engine for 2 hours and retest the coolant. Continue process until SCA concentration meets recommended levels.
3. SCA is available from your Northern Lights dealer in the following sizes.
Pint - Part Number.....20-00002
1/2 gallon - Part Number.....20-00003
4. **DO NOT** use any coolant system additives containing soluble oil.

COOLANT TESTING

1. Coolant test kits are available to allow on-site evaluation of the coolant condition.
2. The kits use small strips of paper which are dipped into the coolant. The paper changes color and indicates the SCA concentration. It also indicates the amount of EGC (antifreeze).
3. Test kits are available through your Northern Lights Dealer.
4 Pack - Part Number.....20-00005
50 Pack - Part Number.....20-00010

SP14. CHECKING COOLANT LEVEL.



CAUTION: The cooling water in the engine reaches extremely high temperatures. You must use extreme caution when working on hot engines to avoid burns. Allow the engine to cool before working on the cooling system. Open the filler cap carefully, using protective clothing when the engine is warm.

1. Check the coolant level each day before starting the engine.
2. Remove the pressure cap from the expansion tank and check water level. In order to give the coolant an opportunity to expand, the level should be about 1 3/4 in. (4-5 cm) below the filler cap sealing surface when the engine is cold. When filling with coolant, the venting cock on top of the turbocharger (for engines fitted with turbocharger) should be opened to ensure that no air pockets form in the cooling system.
3. The pressure valve in the filler cap releases when the pressure is approximately 7 PSI (0.5 bar). Use a cap pressure tester to check cap if you suspect it is faulty.
4. The makeup coolant, added to compensate for loss or leaks, must meet engine coolant requirements outlined in previous section.

SP15. FLUSHING THE COOLING SYSTEM

CAUTION: *The cooling water in the engine reaches extremely high temperatures. You must use extreme caution when working on hot engines to avoid burns. Allow the engine to cool before working on the cooling system. Open the filler cap carefully, using protective clothing when the engine is warm.*

1. Flush the cooling system and check for leaks and blockage every 600 hours, or yearly. **The engine must be stopped and cold.**
2. Close the seacock.
3. Remove the pressure cap from the expansion tank with caution. If applicable, open the cooling system air vent on top of turbocharger.
4. Open the drains on the exhaust manifold and engine block. Drain the fresh water system (see Component Locations, page 4).
5. For vessels with keel cooling, the vessel must be out of the water to allow draining of the keel cooler.
6. With drains open, pour clean water into the expansion tank. When the water from drain is clear and free from discoloration and sediment, close that drain. When all drains are closed, flushing is complete.
7. Fill the fresh water system by pouring the recommended coolant mixture as described in previous sections.
8. Close cooling system air vent on turbocharger.
9. Open the seacock.
10. Start the engine. Check hoses and connections and repair any leakage.

SP16. HEAT EXCHANGER CLEANING

1. Drain the cooling system.
2. Remove the cooling water pipes between the heat exchanger and the water pump inlet.
3. Disconnect hose to seawater pump.
4. Unscrew the attaching bolts holding the heat exchanger to the expansion tank.
5. Remove bolts holding heat exchanger cover.
6. Wash the core inside and out. If necessary, chemical agents can be used. Also clean the accessible parts of the heat exchanger housing.
7. Reassemble, using new gaskets and sealing rings.

SP18. ZINC ANODES

1. Zincs are installed in the cooling system to protect your engine from electrolysis. Check them faithfully every 250 hours. If you are in warm salt water or where electrolysis is a known problem, check them more often.

Heat exchanger cooled engine:

- a. Drain the raw water from heat exchanger (see Component Locations).
- b. Remove zinc holders from back of the tank and from front and port side of the heat exchanger (see Component Locations).

Keel Cooled engines.

- a. Drain expansion tank and remove zinc holder from tank (see Component Locations).
2. Scrape or steel brush the zinc electrode clean. If more than 50% of the electrode has eroded away, replace it with a new one. The electrode screws out of the holder.
3. Reinstall the zinc holders. Be sure the threads are clean and have good metal to metal contact.

SP19. RAW WATER PUMP

Heat exchanged cooled engines only.

1. Change the sea water pump impeller as needed.
2. Remove the pump end cover. Remove impeller with water pump pliers. Be sure you remove all pieces of a failed impeller.
3. Clean the inside of the housing.
4. Press in the new impeller and place the sealing washer in the outer end of the impeller center if this has not already been done.
5. Replace the cover using a new gasket.

Note: *Make sure there is always an extra impeller and cover gasket in reserve and on-board.*

DRIVEN EQUIPMENT

Gears and PTO's

1. Manufacturer's service recommendations vary. See your Owner's Manual for service information. If you do not have a manual, see your local dealer for the equipment in question.



NOTE: Some PTO and marine gears have rigid lubrication requirements. Follow service recommendations closely.

ELECTRICAL SYSTEM - GENERAL

1. Never switch battery switch off or break the circuit between the alternator and batteries while the engine is running. Regulator damage can result.
2. DO NOT reverse the polarity of battery cables when installing the battery.
3. When welding on the unit, disconnect the regulator and battery. Isolate the leads.
4. Disconnect battery cables when servicing the DC alternator.
5. Never test with a screwdriver, etc., against any terminal to see if it emits sparks.
6. A DC circuit breaker protects your control panel and wiring harness.

PRECAUTIONS FOR WELDING ON VESSELS WITH AN ELECTRONIC ENGINE CONTROL UNIT (ECU)



Caution: Always disconnect the Electronic Control Unit connectors and engine control system-to-vessel ground before welding. High currents or electro-static discharge in electronic components from welding may cause permanent damage.

1. Remove the ground connection for the engine control system-to-vessel frame.
2. Disconnect the connectors from the ECU.
3. Connect the welder ground close to the welding point and be sure that the ECU or other electronic components are not in the ground path.

BOOSTER BATTERIES

CAUTION: Battery Gas Can Explode. Keep all flames and sparks away from batteries.

1. Before changing or using booster batteries, check battery electrolyte level. Add distilled water.
2. Booster and main batteries must have the same voltage rating.
3. First, connect positive (+) terminal of booster battery to positive (+) terminal of main battery.

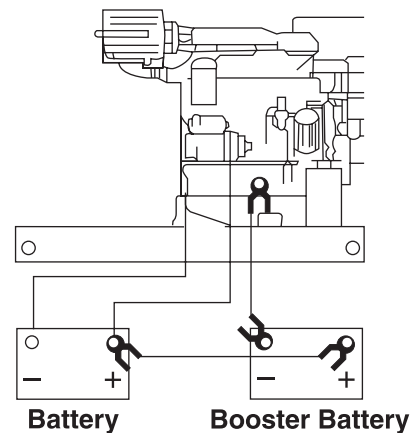

Figure 4: Booster Battery Connections

4. Then, connect negative (-) terminal of booster battery to ground on the engine block (see Figure 4).
5. Remove booster battery after starting engine.
6. Sealed batteries: see manufacturer charging and booster instructions.

SP20-21. BATTERY CARE - LEAD/ACID TYPE BATTERIES

1. Check electrolyte level every 50 hours or once per month. Add distilled water to manufacturer's recommended level.
2. Batteries, cables and cable terminals should be checked and cleaned every 100 hours. Clean corrosion with a water and baking soda solution. Flush with clean water. Tighten terminals and grease them to inhibit corrosion.
3. Check the battery condition with a hydrometer every 750 hours.

SP22. WINTERIZING, OUT-OF-SERVICE

The following long term storage preparation guides are good for storage up to one year, after that the engine should be started, warmed up, and prepared again for long term storage.

1. Change oil and replace filter. Used oil will not give adequate protection.
2. Service the air cleaner.
3. For storage less than a year it is not necessary to drain and flush the cooling system. For a year or more of storage the cooling system should be drained, flushed and refilled with appropriate coolant.
4. Remove the fan and alternator belts, optional.
5. Remove and clean the batteries. Store them in a cool dry place and be sure they are fully charged.
6. Disengage the clutch to engine drivelines.
7. Clean the exterior of the engine with salt-free water and touch up painted surfaces with good paint.
8. Coat all exposed machined metal surfaces with grease or corrosion inhibitors if they cannot be painted.
9. Seal all openings with plastic bags and tape.
10. Store the engine in a dry protected place. If the engine must be outside, cover with waterproof canvas or other protective material and use strong waterproof tape.

Troubleshooting

If you cannot correct problems with these procedures, see your **Lugger or Northern Lights** dealer.

✓ Engine Will Not Crank

Weak battery:

- Replace battery.

Corroded or loose battery connections:

- Clean battery terminals and connections.

Defective main switch or start safety switch:

- Repair switch as required.

Starter/solenoid defective:

- Replace starter or solenoid.

✓ Hard to Start or Will Not Start

Poor fuel quality:

- Drain fuel and replace with proper grade fuel.

Slow cranking speed:

- Check for problems in the charging or starting system.

Electronic Control System Problem:

- See your local dealer.

✓ Engine Misfiring or Runs Irregularly

Electronic Control System problem or basic engine problem:

- See your dealer.

✓ Lack of Engine Power

Poor fuel quality:

- Drain fuel and replace correct grade fuel.

Intake air restriction:

- Service air cleaner.

Clogged primary fuel filter:

- Clean or replace filter element.

Clogged secondary fuel filter element:

- Replace secondary filter element.

Crankcase oil too heavy:

- Fill with oil of appropriate viscosity.

Electronic Control System problem or basic engine problem:

- See your dealer.

✓ Low Oil Pressure

Low crankcase oil level:

- Fill crank case to proper level.

Clogged oil cooler or filter:

- Remove and inspect oil cooler. See your dealer.

High oil temperature:

- Remove and inspect oil cooler. See your dealer.

Defective oil pump:

- Remove and inspect oil pump. See your dealer.

Oil pressure regulating valve failure:

- Remove and inspect oil pressure regulating valve. See your dealer.

Broken piston spray jet:

- Replace piston spray jet. See your dealer.

Clogged oil pump screen or cracked pick-up tube:

- Remove oil pan and clean screen/ replace pick-up tube.

Excessive main or connecting rod bearing clearance:

- Determine bearing clearance. See your dealer.

✓ High Oil Pressure

Regulating valve not operating correctly:

- Remove and inspect oil pressure regulating valve. See your dealer.

Plugged piston spray jet:

- Replace piston spray jet. See your dealer.

Filter bypass valve stuck or damaged:

- Remove and inspect filter bypass valve. See your dealer.

✓ High Oil Consumption

Crankcase oil too low viscosity:

- Drain crankcase and refill with correct oil.

Crankcase oil level too high:

- Drain oil until level is correct.

External oil leak:

- Check for leaks in lines around gaskets and drain plug.

Oil control rings worn or broken:

- Replace piston rings. See your dealer.

Scored cylinder liners or pistons:

- Remove and inspect cylinders and liners; replace as required. See your dealer.

Worn valve guides or stems:

- Inspect and measure valve stems and valve guides; repair as required. See your dealer.

Piston grooves worn:

- Remove and inspect pistons. See your dealer.

Piston rings sticking in ring grooves:

- Remove and inspect pistons. See your dealer.

Insufficient piston ring tension:

- Remove and inspect pistons. See your dealer.

Piston ring gaps not staggered:

- Remove and inspect pistons. See your dealer.

Front and/or rear crankshaft oil seal faulty:

- Replace oil seals. See your dealer.

If you cannot correct problems with these procedures, see your **Lugger or Northern Lights** dealer.

✓ Excessive Fuel Consumption

Intake air restriction:

- Service air cleaner.

Improper type of fuel:

- Consult fuel supplier and use proper type of fuel for operating conditions.

Engine overloaded :

- Reduce load on engine.

Compression too low:

- Determine cause of low compression and repair.

Leak in fuel supply:

- Locate source of leak and repair as required.

✓ Abnormal Engine Noise

Worn main or connecting rod bearings:

- Determine bearing clearance. See your dealer.

Excessive crankshaft end play:

- Check crankshaft end play. See your dealer.

Loose main bearing caps:

- Check bearing clearance, replace bearings and bearing cap screws as needed. See your dealer.

Worn connecting rod bushings and piston pins:

- Inspect piston pins and bushings. See your dealer.

Scored pistons:

- Inspect pistons. See your dealer.

Worn timing gears or excessive back lash:

- Check timing gear back lash. See your dealer.

Excessive valve clearance:

- Check and adjust valve clearance. See your dealer.

Worn camshaft lobes:

- Inspect camshaft. See your dealer.

Worn rocker arm shafts:

- Inspect rocker arm shafts. See your dealer.

✓ Engine Emits Black or Gray Exhaust Smoke

Clogged or dirty air cleaner:

- Service air cleaner.

Defective muffler (back pressure too high):

- Have dealer check back pressure.

Improper fuel:

- Use correct fuel for temperature.

Electronic Control System problem:

- See your dealer.

✓ Engine Emits White Smoke

Engine compression too low:

- Determine cause, see dealer.

Defective thermostat (does not close):

- Remove and check thermostats, replace if needed.

Coolant entering combustion chamber, maybe a failed cylinder head gasket or cracked cylinder head:

- Repair, see your dealer. ✓ **Engine**

Emits White Smoke

Water-to-air aftercooler fails:

- Remove and inspect water-to-air aftercooler. See your dealer.

✓ Engine Idles Poorly

Improper type of fuel:

- Replace with correct fuel grade.

Air leak on suction side of air intake:

- Check hose and pipe connections for tightness, repair as required.

Electronic control system problem:

- See your dealer.

Diagnostic Trouble Codes

Diagnostic Trouble Codes (DTCs) are found on the diagnostic gauge as 2 part code, according to the J1939 standard. The first part is a 2 to 4 digit Suspect Parameter Number (SPN). The second part is a 1 or 2 digit Failure Mode Identifier (FMI) code. The diagnostic code will be on the first line of the gauge readout and the second line will have "SvcCode" on it. The following is a table of the SPNs, FMIs, and description of the diagnostic fault codes that can occur in various engine systems. Not all of the codes will be present in all engine applications. When these trouble codes appear on the gauge see your dealer as soon as possible for repairs.

SPN	FMI	Description
29	03	Throttle #2 Input High
29	04	Throttle #2 Input Low
91	03	Throttle #1 Input High
91	04	Throttle #1 Input Low
94	01	Fuel Supply Pressure Extremely Low
94	03	Fuel Supply Pressure Input Voltage High
94	04	Fuel Supply Pressure Input Voltage Low
94	16	Fuel Supply Pressure Moderately High
94	18	Fuel Supply Pressure Moderately Low
97	00	Water in Fuel - Continuously Detected
97	03	Water in Fuel Signal - Voltage High
97	04	Water in Fuel Signal - Voltage Low
97	16	Water in Fuel Detected
100	01	Engine Oil Pressure Extremely Low
100	03	Engine Oil Pressure Input Voltage High
100	04	Engine Oil Pressure Input Voltage Low
100	18	Engine Oil Pressure Moderately Low
110	00	Engine Coolant Temperature Extremely High
110	03	Engine Coolant Temperature Input Voltage High
110	04	Engine Coolant Temperature Input Voltage Low
110	16	Engine Coolant Temperature Moderately High
158	17	ECU Power Down Error
174	03	Fuel Temperature Input Voltage High
174	04	Fuel Temperature Input Voltage Low
611	03	Injector Wiring Shorted to Power Source
611	04	Injector Wiring Shorted to Ground
627	01	Injector Supply Voltage Problem
629	13	ECU Error
636	02	Cam Position Input Noise
636	08	Cam Position Input Missing
636	10	Cam Position Input Pattern Error
637	02	Crank Position Input Noise

Diagnostic Trouble Codes

SPN	FMI	Description
637	08	Crank Position Input Missing
637	10	Crank Position Input Pattern Error
651	05	Cylinder #1 EUI Circuit Open
651	06	Cylinder #1 EUI Circuit Shorted
652	05	Cylinder #2 EUI Circuit Open
652	06	Cylinder #2 EUI Circuit Shorted
653	05	Cylinder #3 EUI Circuit Open
653	06	Cylinder #3 EUI Circuit Shorted
654	06	Cylinder #4 EUI Circuit Open
654	06	Cylinder #4 EUI Circuit Shorted
655	05	Cylinder #5 EUI Circuit Open
655	06	Cylinder #5 EUI Circuit Shorted
656	05	Cylinder #6 EUI Circuit Open
656	06	Cylinder #6 EUI Circuit Shorted
1569	31	Fuel Derate

NOTE: The Diagnostic Gauge on the electronic instrument panel could have communication problems that could result in error codes being shown on its LCD display. The following error codes all indicate that there is a diagnostic gauge communication error with the ECU. Contact your dealer for help in correcting these codes.

EE - Error

XXXXX - EP
No Data

ACP - Err
No Addr

XXXXX - BO
No Data

ACP - Err

XXXXX - BR
No Data

BUS - EP

Specifications

L6125H Specifications and Installation Data

Output rating	Continuous	Medium	High Output
FWHP ¹ (kW) ²	350 (261)	440 (328)	470 (350)
Maximum RPM	1800	2200	2300
Cylinders/Configuration/Cycle	All: 6 / Inline / 4		
Displacement CID (ltr)	All: 674 (11)		
Aspiration	All: Turbocharged - Aftercooled		
Bore x Stroke in (mm)	All: 4.92 x 5.91 (125 x 150)		
Cooling (Heat Exchanger)			
Seawater pump flow - US gpm (lpm)	58 (219)	71 (269)	74 (280)
Heat rejection to sea water - BTU-min	8040	11350	13390
Freshwater system capacity - US gal (ltr)	All: 9 (34)		
Raw water intake dia. - in (mm)	All: 2 (51)		
Raw water discharge dia. - in (mm)	All: 2 (51)		
Max. raw water temp. at inlet -°F (°C)	All: 86° (30°)		
Electrical			
Voltage	All: 24V standard ground		
Min. battery capacity	All: 200 amp hours - 800 CCA		
Battery cable size up to 10 ft run	All: 00		
Standard panel harness length - ft (m)	All: 20 ft (6m)		
Air and Exhaust			
Engine air consumption - cfm (m ³ /min)	590 (16.7)	936 (26.5)	1024 (29)
Exhaust gas flow at - cfm (m ³ /min)..	1715 (49)	2323 (66)	2508 (71)
Exhaust gas temperature -°F (°C)	961 (516)	777 (414)	759 (404)
Max. exhaust back pressure - in (mm) H ₂ O	All: 30 (762)		
Suggested dry exhaust I.D. - in (mm)	All: 6		
Suggested wet exhaust I.D. - in (mm)	All: 8		
Fuel and Oil			
Minimum fuel suction line - in (mm)	All: 0.5 (12)		
Minimum fuel return line - in (mm)	All: 0.38 (10)		
Maximum fuel pump head - in (m)	All: 39 (1)		
Crankcase oil capacity - US qts (ltr)	All: 34 (32)		
Other Data			
Engine rotation (facing flywheel)	All: Counter-Clockwise		
Flywheel housing size	All: #1 SAE		
Optional front PTO size SAE # - inch	All: 4 -8", 4 -10" or 3 -11.5"		
Maximum operating angle any direction	All: 35° for less than 2 minutes		
Maximum installed operating angle	All: 10° rear down - 0° front down		
Heat Exchanger Weight - without gear	2867 lbs (1300 kg)		

1. Flywheel Horsepower ratings based on SAE J816b.

2. Kilowatt ratings based on EN ISO 8665: 2006

On Board Spare Parts

Safety at sea depends on careful preparation, product knowledge, and having the right tools and parts. Below is a list of parts Alaska Diesel Electric, Inc. recommends you carry onboard at all times.

Onboard Parts Kits are available from your dealer.

We consider these minimum quantities. Your vessel's operating conditions may require more of a given part. Consult your dealer.

Item	Description	Qty
1	Oil Filter	4
2	Air Filter Element	1
3	Fuel Filter Element	4
4	Fuel Transfer Pump	1
5	Oil Separator Element	2
6	Injector	1
7	Thermostat	2
8	Thermostat Cover Gasket	1
9	Speed Sensor	1
10	Rocker Arm Cover Gasket	1
11	Gasket Kit, Engine Overhaul	1
12	Bearing	2
13	Zinc Anode*	6
14	Raw Water Pump Impeller w/Gasket*	2
15	Raw Water Pump*	1
16	Coolant Pump Repair Kit	1
17	Workshop Manual	1
18	Drive Belts	2

*Heat exchanger cooled engines only

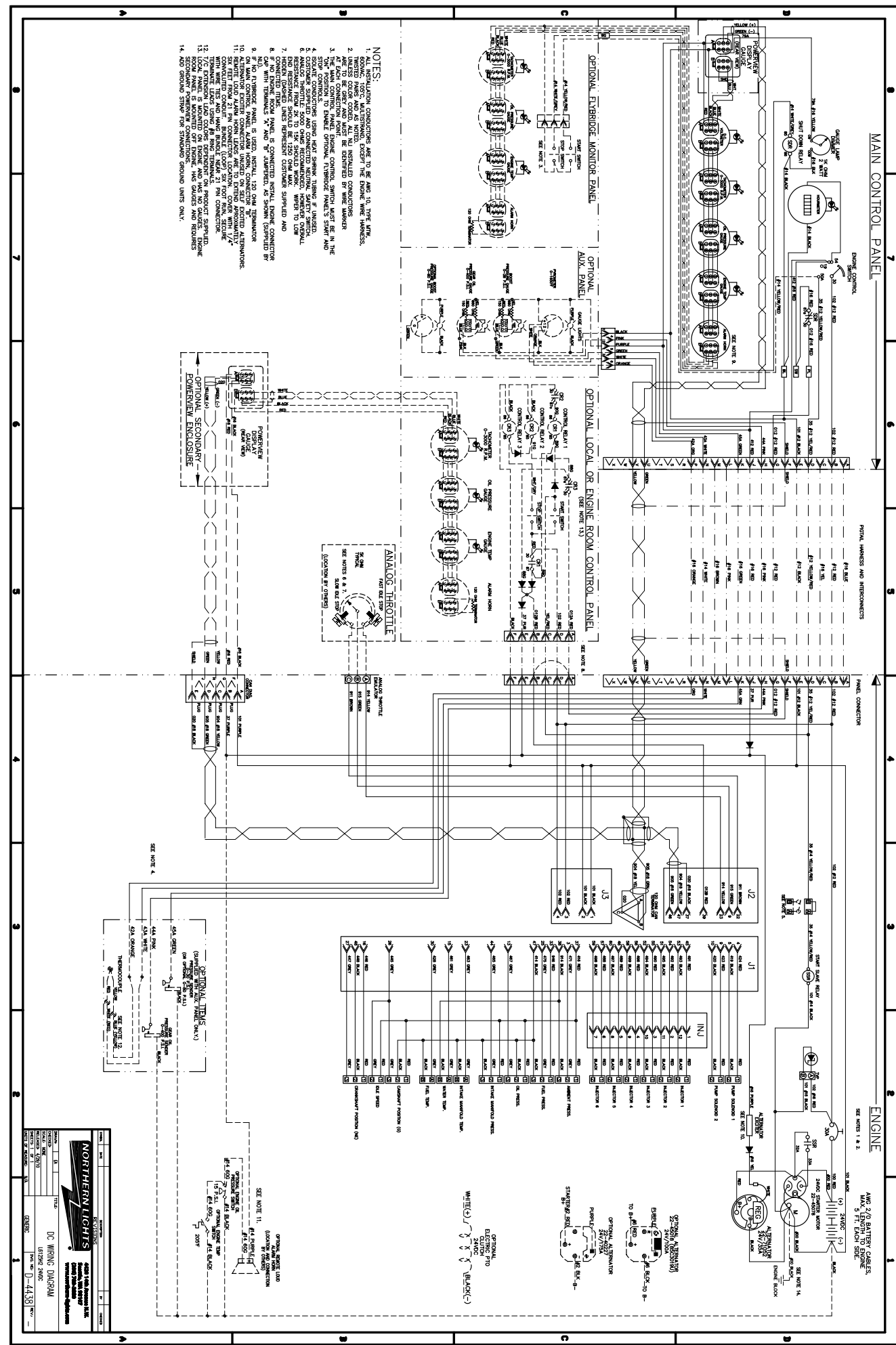

MAIN CONTROL PANEL

ENGINE

AWG 2/0 BATTERY CABLES
MAX. LENGTH TO ENGINE
SEE NOTES 1 & 2

NOTES

1. INSULATION CONDUCTORS ARE TO BE AWG 10, TYPE UTM.
2. FUSING 100% ALTERNATIVE, EXCEPT THE ENGINE WIRE HARNESS.
3. ALL WIRE HARNESS AND ALL THE INSTALLED CONDUCTORS AT EACH CONNECTION POINT BE IDENTIFIED BY THE WIREMARKER.
4. THE MAIN CONTROL PANEL ENGINE CONTROL SWITCH MUST BE IN THE STOP POSITION.
5. CUSTOMER SUPPLIED AND CONNECTED NEUTRAL SAFETY SWITCH.
6. RESISTANCE FROM 2X TO 15X SHOULD WORK. REFER TO UOM.
7. HOLEY COVERED WIRE REPRESENTS CUSTOMER SUPPLIED AND CONNECTED WIRE.
8. LOCAL PANEL IS CONNECTED INSTALL ENGINE CONNECTOR WITH TERMINALS 'X' AND 'Y' JUMPERS, AS SHOWN (SUPPLIED BY CUSTOMER).
9. IF A THERMISTOR IS USED, INSTALL 1.20 OHM THERMISTOR.
10. ALTERNATIVE ENGINE CONNECTOR UNLESS ON SELF EXCITED ALTERNATORS.
11. SEE FIG. 21 FOR CONNECTOR LOCATION COVER WITH 1/2" CONDUIT AND 1/2" WIRE BUNDLE.
12. TERMINAL LEADS USED AS BOND TERMINALS.
13. LOCAL PANEL IS MOUNTED ON ENGINE AND HAS NO GAGES, ENGINE SECONDARY POWER CONNECTIONS, AND GAGES AND RECORDS.
14. ADD GROUND STRAP FOR STANDARD BROWN UNITS ONLY.

NORTHERN LIGHTS
4000 17th Avenue S.E.
Edmonton, Alberta T6C 1K7
Canada
Tel: (780) 443-1111
Fax: (780) 443-1112
E-mail: sales@northernlights.com

DC WIRING DIAGRAM
REV. 01/2018
D-41381

Notes



4420 14th Ave. NW., Seattle WA 98107

Tel: (206) 789-3880 • 1-800-762-0165 • Fax: (206) 782-5455

Northern Lights and Lugger are registered trademarks of Northern Lights, Inc.

© 2010 All rights reserved. Litho USA.