

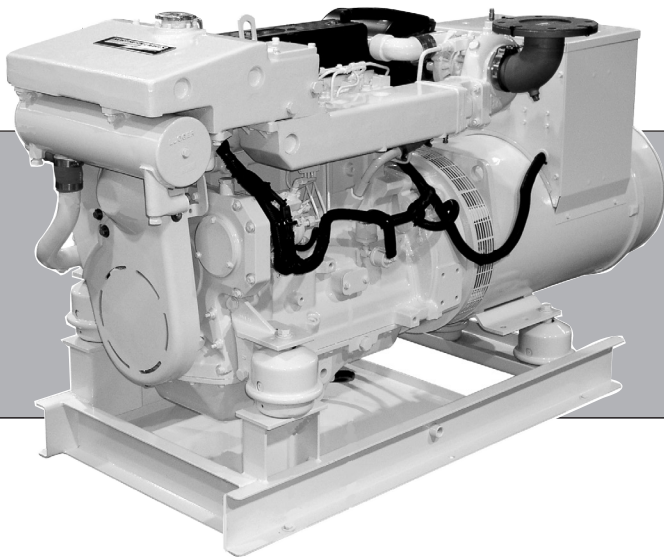

OPERATOR'S MANUAL

OM2-2

For Models: M1064A, M1064D, M1064T1, M1064T2,
M1066A1, M1066A2, M1066A3, M1066T, M40C2, M55C2,
M65C2 and M99C2



www.northern-lights.com



— CALIFORNIA —
Proposition 65 Warning:

Breathing Diesel engine exhaust and some of its constituents are known to the State of California to cause cancer, birth defects, and other reproductive harm.

- * Always start and operate the engine in a well-ventilated area.
- * If in an enclosed area, vent the exhaust to the outside.
- * Do not modify or tamper with the exhaust system.
- * Do not idle the engine except as necessary.

For more information, go to www.P65warnings.ca.gov/diesel.

Northern Lights

4420 14th Avenue NW
Seattle, WA 98107
Tel: (206) 789-3880
Fax: (206) 782-5455

Copyright ©2018 Northern Lights, Inc.
All rights reserved. Northern Lights™, and
the Northern Lights logo are trademarks of
Northern Lights, Inc.

Printed in U.S.A.
PART NO.: OM2-2 10/18



OPERATOR'S MANUAL

for Models:

**M1064A, M1064D, M1064T1, M1064T2, M1066A1, M1066A2,
M1066A3, M1066T, M40C2, M55C2, M65C2, and M99C2**

*Read this operator's manual thoroughly before starting to operate your equipment.
This manual contains information you will need to run and service your new unit.*

Table of Contents

INTRODUCTION	2	Fuel Filters	21
Models Included	2	Bleeding the Fuel System	22
Model Numbers	2	Crankshaft Vibration Damper (6 Cyl.)	22
Serial Numbers	2	Injector Service	22 - 24
WARRANTY	3	Injection Pump	24 - 26
SAFETY RULES	3 - 7	Turbocharger	27
Lockout / Tag Out Procedures	8	Turbo Boost	27
COMPONENT LOCATIONS		Cooling Requirements	27 - 29
M1064	10	Checking Cooling Level	29
M1066	11	Flushing Cooling System	29
M40C2	12	Heat Exchanger Cleaning	29
CONTROL PANELS		Zinc Electrodes	30
Series 3B	13	Raw Water Pump	30
Series 4B	14	Booster Batteries	30-31
Emission-Related Installation Instructions	15	Battery Care	31
OPERATING PROCEDURES		Crankcase Vent System	31
Before Starting	15	Aftercooler	31
Shutdowns and Alarms	16	Winterizing / Out-of-Service	31
Break-In Period	16	TROUBLESHOOTING	
SERVICING SCHEDULE CHARTS	17 - 18	Engine	32-33
SERVICING		Electrical	34
Lubrication - General	19	WIRING DIAGRAMS	
Checking Oil	19	AC Wiring	35 - 37
Oil Changes	19	DC Wiring	38 - 45
Changing Oil Filter	19	Panel Wiring	47 - 49
Air Filter	19	ON-BOARD SPARE PARTS	52
Valve Clearances	20		
Fuels - General	21		

Proprietary Information

This publication is the property of Northern Lights, Inc.

It may not be reproduced in whole or in part without the written permission of Northern Lights, Inc.

© Northern Lights, Inc. All rights reserved. Litho U.S.A. Publication number OM2-2 10/18

Introduction

Servicing of marine engines and generator sets presents unique problems. In many cases boats cannot be moved to a repair facility. Marine engines cannot be compared to the servicing of automobiles, trucks or even farm equipment. Failures often occur in remote areas far from competent assistance. Marine engines are taxed far more severely than auto or truck engines; therefore, maintenance schedules must be adhered to more strictly.

Failures begin with minor problems that are overlooked and become amplified when not corrected during routine maintenance.

As operator, it is your obligation to learn about your equipment and its proper maintenance. This is not a comprehensive technical service manual. Nor will it make the reader into an expert mechanic. Its aim is to aid you in maintaining your unit properly.

Model Numbers

Model numbers give the unit's application, block model, aspiration, and RPM:

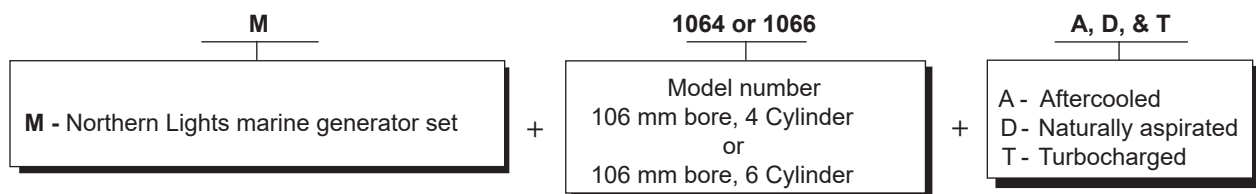

- | | | | |
|----------------|--|---------------|--|
| M1064A | = Northern Lights® aftercooled, 1800 RPM marine diesel generator set with a John Deere Powertech Tier II 4045 engine block with an electronically controlled fuel system. | M1066T | = Northern Lights® turbocharged marine generator set with a John Deere Powertech Tier II 6068 engine block with an electronically controlled fuel system. |
| M1064D | = Northern Lights® naturally aspirated, 1800 RPM marine diesel generator set with a John Deere Powertech Tier II 4045 engine block with a mechanically controlled fuel system. | MP40C2 | = 40 kW Northern Lights® commercial marine generator set with a John Deere Powertech Tier II 4045 engine block with a mechanically controlled fuel system. |
| M1064T1 | = Northern Lights® turbocharged marine generator set with a John Deere Powertech Tier II 4045 engine block with a mechanically controlled fuel system. | MP55C2 | = 55 kW Northern Lights® commercial marine generator set with a John Deere Powertech Tier II 4045 engine block and a mechanically controlled fuel system. |
| M1064T2 | = Northern Lights® turbocharged marine generator set with a John Deere Powertech Tier II 4045 engine block with an electronically controlled fuel system. | MP65C2 | = 65 kW Northern Lights® commercial marine generator set with a John Deere Powertech Tier II 6068 engine block and an electronically controlled fuel system. |
| M1066A1 | = Northern Lights® aftercooled marine generator set with a John Deere Powertech Tier II 6068 series 1 engine block with an electronically controlled fuel system. | MP99C2 | = 99 kW Northern Lights® commercial marine generator with a John Deere Powertech Tier II 6068 engine block and an electronically controlled fuel system. |

Serial Numbers

When referencing Northern Lights equipment by serial number, please refer only to the number stamped on the Northern Lights® serial number plate.

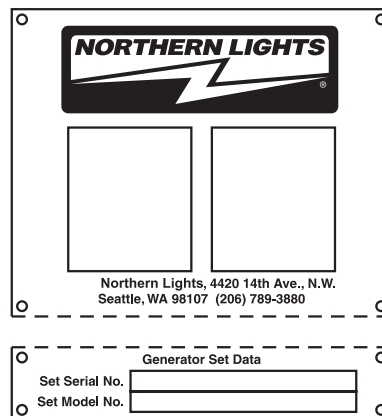

Warranty

A warranty registration certificate is supplied with your set. The extent of coverage is described in the Limited Warranty Statement. We recommend that you study the statement carefully.

NOTE: If the warranty is to apply, the servicing instructions outlined in this manual must be followed. If further information is needed, please contact an authorized dealer or the factory.

Safety Rules



NOTICE: Accident reports show that careless use of engines causes a high percentage of accidents. You can avoid accidents by observing these safety rules. Study these rules carefully and enforce them on the job.

IMPORTANT SAFETY INSTRUCTIONS.

Electromagnetic equipment, including generator sets and their accessories, can cause bodily harm and life threatening injuries when improperly installed, operated or maintained. To prevent accidents be aware of potential dangers and act safely.

on parts and components from outside suppliers that is not reproduced in this manual. Consult the suppliers for additional safety information.

Learn how to operate the machine and how to use the controls properly. Only trained personnel should operate machines, or work on or around them.



READ AND FOLLOW ALL SAFETY INSTRUCTIONS IN THIS MANUAL, PRIOR TO THE INSTALLATION OF ANY GENERATOR SET OR ACCESSORY. KEEP THESE INSTRUCTIONS FOR FUTURE REFERENCE.

Keep you machine in proper working condition. **UNAUTHORIZED MODIFICATIONS TO THE MACHINERY MAY IMPAIR ITS FUNCTION AND SAFETY PARAMETERS.**

Recognize Safety Symbols and Instructions

In addition to the information found in this section, this operator's manual uses three different signal words to outline potential dangers of a specific nature.

	DANGER DANGER indicates a hazardous situation which, if not avoided, will result in death or serious injury.
	WARNING WARNING indicates a hazardous situation which, if not avoided, could result in death or serious injury.
	CAUTION CAUTION indicates a hazardous situation which, if not avoided, could result in minor or moderate injury.

Prevent Bypass and Accidental Starting



Do not start engine by shorting across start terminal. Engine will start if normal circuitry is bypassed, creating a hazard by runaway machinery.



Start engine only from operator's station.

Follow All Safety Instructions

Carefully read and understand all safety messages in this manual and on your machine's safety signs. Keep signs in good and clean condition. Replace missing or damaged signs. Be sure new equipment components and repair parts include the current safety signs. For replacement signs, proper placement of safety signs or clarification on any safety issue, consult your Northern Lights dealer or the factory. There can be additional safety information contained



Handle Fuel Safely - Avoid Flames



Diesel is highly flammable and should be treated with care at all times. Do not refuel while smoking or when near sparks or open flame.

ALWAYS STOP ENGINE BEFORE FUELING MACHINE. Always fill portable fuel tank outdoors. Never fuel a hot engine.



Safety Rules (Continued)

Prevent accidental discharge of starting fluids by storing all cans in a cool, safe place, away from sparks or open flame. Store with cap securely on container. Never incinerate or puncture a fuel container.

Prevent fires by keeping machine clean of accumulated trash, grease and debris. Always clean any spilled fuel as swiftly as possible. Do not store oily rags, which can ignite and burn spontaneously.

Be prepared if a fire starts. Keep a first aid kit and fire extinguisher handy. Keep emergency contact numbers for fire department, doctors, ambulance and hospital near the telephone.

Service Machines Safely

! DANGER

Do not wear a necktie, scarf, necklace, rings or other jewelry, or any loose clothing when working near moving parts. Tie long hair behind your head. If any of these items get caught in moving machinery, severe injury or death could result.

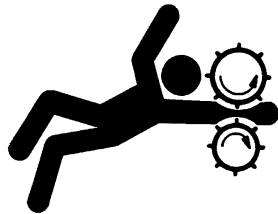

Check for any loose electrical connections or faulty wiring.

Look completely around engine to make sure that everything is clear before starting.

Wear Protective Clothing

! WARNING

To prevent catching anything in moving machinery, always wear close fitting clothes and safety equipment appropriate to the job.

Prolonged exposure to loud noise can cause hearing loss or impairment.

Wear suitable authorized hearing protection, such as earmuffs or plugs to protect against loud noises

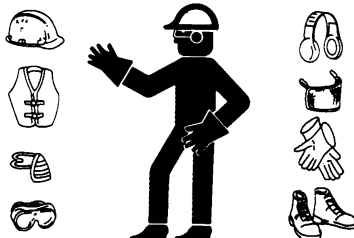

Operating equipment requires the full attention of the operator. Do not use radio or music headphones while operating machinery.

Practice Safe Maintenance

! CAUTION

Understand all service procedures before starting work. Keep area clean and dry. Never lubricate, service, or adjust machine while it is in operation.



Keep hands, feet and clothing away from power-driven equipment. When shutting down an engine, disengage all power and operator controls. Allow the engine to cool completely before beginning any service work.

Securely support any machinery elements that must be raised for service work with support or lifting machinery specifically intended for that purpose.

Keep all parts in good conditions and properly installed. Fix damage immediately. Replace any worn or broken parts. Remove any build up of grease, oil or debris.

Disconnect battery ground cable (-) before making any adjustments or service work.

Stay Clear of Rotating Drivelines

! DANGER

Entanglement in rotating drivelines can cause serious injury or death. Keep shields in place at all times. Make sure that rotating shields turn freely in pace with the drivelines.

Do not wear loose fitting equipment around rotating drivelines. Stop the engine and make sure that all moving parts have stopped before making any adjustments, connections, or performing any other type of service to the engine or other driven equipment.



Safety Rules (Continued)

Install all Safety Guards

WARNING

Direct contact with rotating fans, belts, pulley and drives can cause serious injury.

Keep all guards in place at all times during engine operation.

Wear close-fitting clothes. Stop the engine and be sure all fans, belts, pulleys and drives are stopped before making adjustments, connections, or cleaning near fans and their components.

Do not allow anything on your person to dangle into or come in contact with a moving fan, belt, pulley or drive. Fans can act as vacuums and pull materials up from below, so avoid that area as well while in service.

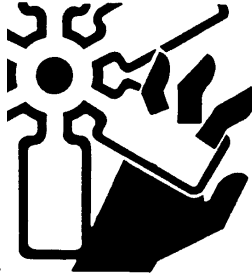

Safe Battery Handling

WARNING

Prevent Battery Explosions

Battery gas is highly flammable. Battery explosions can cause severe injury or death. To help prevent battery explosions, keep sparks, lighted matches and open flame away from the top of battery. When checking battery electrolyte level, use a flashlight.

Never check battery charge by contacting the posts with a metal object. Use a volt-meter or hydrometer.

Frozen batteries may explode if charged. Never charge a battery that has not been allowed to warm to at least 16°C (60°F).

Always remove grounded (-) battery clamp first and replace ground clamp last.

Sulfuric acid in battery electrolyte is poisonous and strong enough to burn skin, eat holes into clothing and other materials, and cause blindness if splashed into eyes.



To Avoid Hazards:

- Fill batteries only in well-ventilated areas.
- Wear appropriate eye protection and rubber gloves.
- Never use air pressure to clean batteries.
- Wear appropriate ventilation equipment to avoid inhaling fumes when adding electrolyte.
- Do not spill or drip electrolyte.
- Use correct jump-start procedure if required.

If acid is spilled on skin or in eyes:

1. Flush skin with water.
2. Apply baking soda or lime to help neutralize acid.
3. Flush eyes with water for 15-30 minutes.
4. Get medical attention immediately.

If acid is swallowed:

1. **DO NOT** induce vomiting.
2. Drink large amounts of water or milk, without exceeding 2 liters (2 quarts)
3. Get medical attention immediately

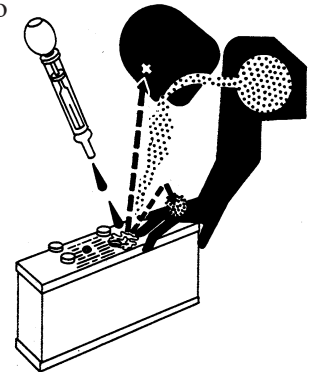

WARNING

Battery posts, terminals, and related accessories can contain lead and lead compounds, chemicals known to the State of California to cause cancer and reproductive harm. Wash hands after handling.

Handle Chemical Products Safely

WARNING

Direct exposure to hazardous chemicals can cause serious injury. Among the potentially hazardous chemicals that may be used with Northern Lights products are lubricants, coolants, paints and adhesives.

All potentially hazardous chemicals come with a Material Safety Data Sheet (MSDS). The MSDS provides specific details on chemical products, including physical hazards, safety procedures and emergency response techniques

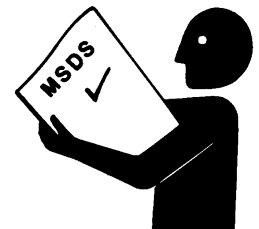

Safety Rules (Continued)

Read and understand the MSDS for each chemical before you start any job that includes it. Follow the procedures and use appropriate equipment exactly as recommended.

Contact your Northern Lights dealer or Northern Lights factory for MSDS's used on Northern Lights products.

Work in Well Ventilated Areas

! CAUTION

Exhaust fumes from engines contain carbon monoxide and can cause sickness or death. Work in well ventilated areas to avoid prolonged exposure to engine fumes. If it is necessary to run an engine in an enclosed area, route the exhaust fumes out of the area with an approved, leak proof exhaust pipe extension.

Remove Paint Before Welding or Heating

! WARNING

Hazardous fumes can be generated when paint is heated by welding, soldering or using a torch. To avoid potentially toxic fumes and dust, remove paint before heating.



- Remove paint a minimum of 100 mm (4 in.) from the area that will be affected by heat.
- If paint cannot be removed, wear an approved respirator.
- If you sand or grind paint, use an approved respirator.
- If you use solvent or paint stripper, remove stripper with soap and water before welding. Remove solvent or paint stripper containers from the area.
- Allow at least 15 minutes for fumes to disperse before welding or heating.

Do not use a chlorinated solvent in an area where welding will occur. Work only in areas that are well ventilated. Dispose of paint and solvent properly.

Service Cooling System Safely

! WARNING

Opening a pressurized cooling system can release explosive fluids and causing serious burns. Before opening any pressurized cooling system, make sure the



engine has been shut off. Do not remove a filler cap unless it is cool enough to comfortably grip with bare hands. Slowly loosen cap to relieve pressure before opening fully.

Avoid High Pressure Fluids

! WARNING

Relieve pressure prior to disconnecting pressurized lines. Escaping fluid under pressure can penetrate the skin causing serious injury. Always relieve pressure before disconnecting hydraulic or other pressurized lines. Tighten all connections firmly before re-applying pressure.



If searching for leaks, use a piece of cardboard. Always protect your hands and other body parts from high-pressure fluids.

If an accident occurs, see a doctor immediately. Any high pressure spray injected into the skin must be removed within a few hours to prevent the risk of gangrene or other infection.

Avoid Heating Near Pressurized Fluid Lines

! WARNING

Flammable spray can be generated by heating near pressurized fluid lines, resulting in severe burns and bodily injury. Pressurized lines can rupture when heat goes beyond the immediate flame area. Do not weld, solder or use a torch or open flame near pressurized lines or other flammable fluids.



Do Not Open High-Pressure Fuel System

! DANGER

Many Northern Lights engines use high-pressure fuel injection. High-pressure fluid remaining in fuel lines can cause serious injury. Do not disconnect or attempt any repair of fuel lines, sensors, or other

Safety Rules (Continued)

components between the high-pressure fuel pump and nozzles on engines with high pressure fuel systems.



ONLY AUTHORIZED TECHNICIANS CAN PERFORM REPAIRS ON AN HIGH PRESSURE FUEL INJECTION SYSTEMS.

Avoid Hot Exhaust



Avoid exposure to and physical contact with hot exhaust gases. Exhaust parts and streams can reach high temperatures during operation, leading to burns or other serious injury.



Cleaning exhaust filters can also lead to exposure to hot exhaust gas and the injury risk associated with it. Avoid exposure to and physical contact with hot exhaust gases when cleaning exhaust filters.

During auto or manual/stationary exhaust filter cleaning operations, the engine will run at elevated temperatures for an extended period of time. Exhaust parts and streams can reach high temperatures during operation, leading to burns or other serious injury.

Avoid Harmful Asbestos Dust



Inhaling asbestos fibers may cause lung cancer. Avoid breathing any dust that may be generated when handling components containing asbestos fibers, including some gaskets.



The asbestos used in these components is usually found in a resin or otherwise sealed. Normal handling of these components is not dangerous, as long as airborne dust containing asbestos is not generated.

Avoid creating dust. Never use compressed air for cleaning. Avoid brushing or grinding materials containing asbestos. When servicing, wear an approved respirator. A special vacuum cleaner is recommended to clean asbestos. If this vacuum is not available, apply a mist of oil or water on the

material containing asbestos. Keep all bystanders away from any area where asbestos dust may be generated.

Use Proper Lifting Equipment and Techniques



Lifting heavy components incorrectly can cause severe injury or damage to machinery. Avoid unbalanced loads. Do not use lifting eyes. Lift the generator set using lifting bars inserted through the lifting holes on the skid. Follow all recommended removal and installation procedures in this and associated Northern Lights manuals.

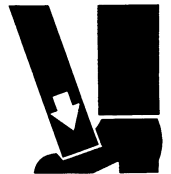

Use Proper Tools



Makeshift tools and procedures can create safety hazards. Always use appropriate tools for the job.



Use power tools only to loosen threaded parts and fasteners. For loosening and tightening hardware, always use the correct sized tools.

Do not use US measurement tools on metric fasteners, or vice versa. Use only service parts that meet Northern Lights specifications.

Dispose of Waste Properly



Disposing of waste improperly can threaten the environment and lead to unsafe working conditions. Potentially harmful waste used in Northern Lights equipment can include oil, fuel, coolant, filters and batteries.

Use leakproof containers to drain fluid. Do not use food or beverage containers that may mislead someone into drinking from them.

Do not pour waste onto the ground, down a drain or into any water source.

Lock Out / Tag Out Procedures

Scope

During maintenance, repairs or retooling of a Northern Lights generator set, simply turning the machine off or unplugging it while it is being worked on does not give enough protection to others who are not performing the maintenance or repair. Many serious accidents happen when someone thought the machine was turned off, or all of its energy was safely blocked or released.

General Policy

⚠ CAUTION

To avoid dangerous or hazardous situations, refrain from any of the following:

- Removing or bypassing a guard or other safety device
- Placing any part of your body in a position where you could be caught by moving machinery.
- Cleaning or oiling machinery when in operation.
- Adjusting circuits, chillers, pumps, air handlers, valves, circuit breakers or fans while in operation.
- Working on piping or high pressure systems.

Lock Out/Tag Out Instructions - Electrical Equipment

⚠ WARNING

Be sure the equipment's ON/OFF switch is in the OFF position and is unplugged from any electrical source before attempting to perform any type of work on the equipment. Obtain an electrical plug cap cover with a lockset. Secure the plug terminal end using the electrical plug lockout cap. Lock the cap and retain the key.

If the equipment is directly wired into an electrical box with a shut off switch, obtain a lock pad and/or the appropriate colored tags and place the lock and tag through the shut off lever. Retain the key until the repair is completed and the machine is safe to start. Be certain the shut off lever is in the OFF position before restarting. NEVER give a lock out key to unauthorized personnel.

If the equipment is directly wired into an electrical box without a shut off switch and lock out capability, then a circuit breaker lock out will be required. Obtain a circuit lock and tag set. Install the lock onto the circuit breaker box. Ensure the unit ON/OFF switch is in the OFF position before restarting.

Lock Out/Tag Out Instructions - Pneumatic and Hydraulic Equipment

⚠ WARNING

For servicing pneumatic and hydraulic equipment, the following additional procedures must be implemented, following completion of lock out/tag out procedures for the unit to be serviced:

Shut off air, water or supply valves at the equipment to be serviced.

Check the local bleed-off point for completed release of pressurized air, water or oil.

If shutting off of air, water or other material cannot be achieved at the local supply valve, shut off valves further back in the system and re-check the bleed-off point until complete shut-off is achieved.

Affix a DO NOT OPERATE tag to each valve handle that requires shut off. Each DO NOT OPERATE tag must be signed and dated by the authorized technician servicing the equipment.

Lock Out/Tag Out Instructions - Air Hose Connected Pneumatic Equipment

⚠ WARNING

Equipment connected to the compressed air system through an air hose with a detachable fitting must be shutdown and unplugged. Excess air must be bled prior to removing the air hose, prior to any maintenance or repair activities.

Affix a DO NOT OPERATE tag to the air hose near the detachable fitting. Each DO NOT OPERATE tag must be signed and dated by the authorized technician servicing the equipment. Check that the equipment cannot be operated by activating the ON switch.

Stored Energy

⚠ WARNING

Immediately after applying Lock Out or Tag Out devices, ensure that all potentially hazardous stored or residual energy is relieved, disconnected, restrained and otherwise rendered safe.

Verification of Isolation

⚠ CAUTION

Verify the machinery or equipment is actually isolated and de-energized prior to beginning work on a machine or on equipment that has been locked out.

Restarting Procedures

⚠ CAUTION

Follow the procedures below prior to restoring energy:

- Ensure that all machinery or equipment is properly reassembled. Inspect the machinery or equipment to verify non-essential items have been removed.
- Ensure that all personnel are safely outside danger zones. Notify personnel that lock out/tag out devices have been removed and energy will be reappplied.
- Only authorized personnel may remove lock out/tag out devices or notices.

Notes

Component Locations

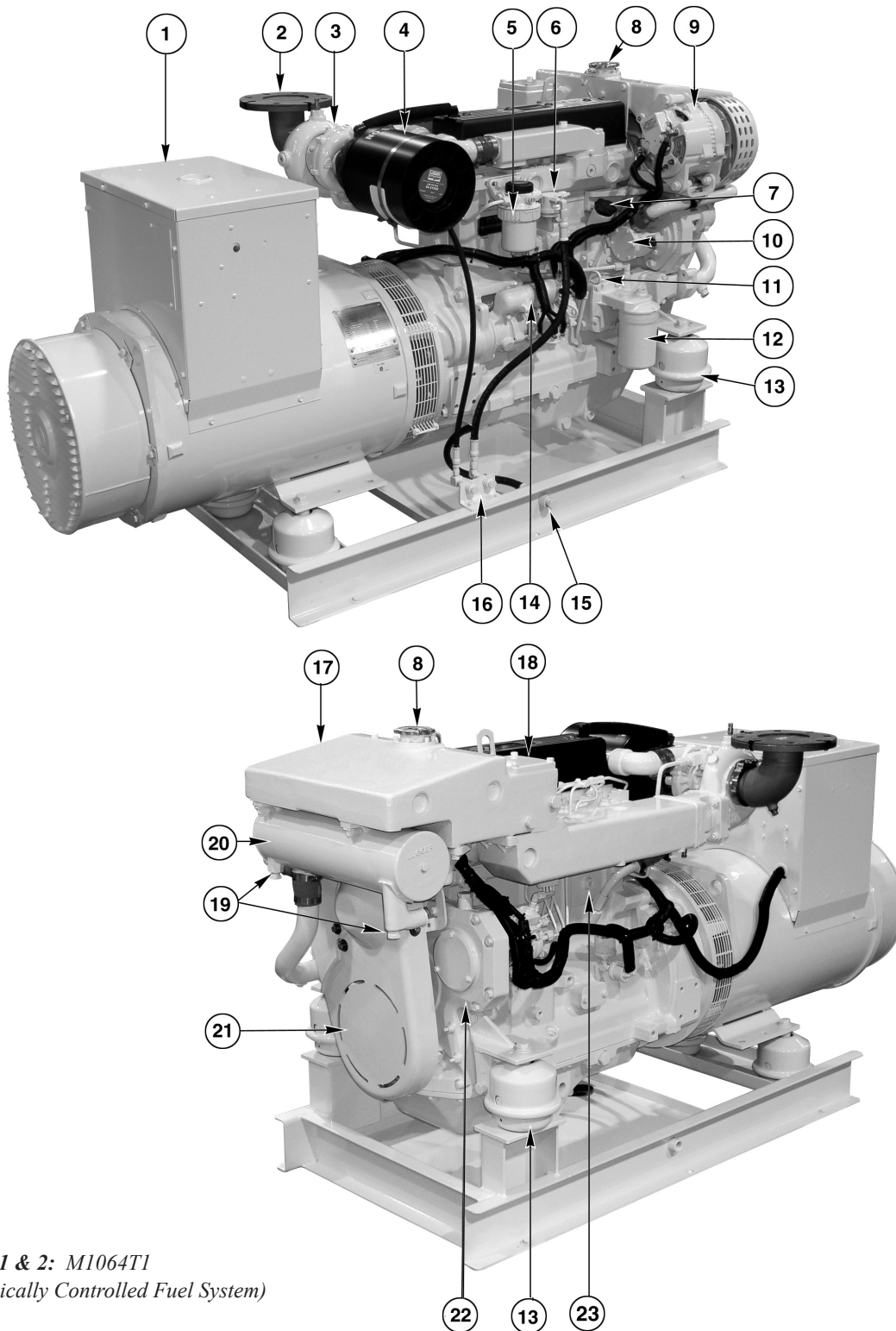

Figures 1 & 2: M1064T1
(Mechanically Controlled Fuel System)

- | | | | |
|-------------------|--------------------------------|--------------------------|--|
| 1. Junction Box | 8. Coolant Fill | 15. Lube Oil Drain | 22. Injection Pump Drive
Coupling Access Cover
Plate |
| 2. Exhaust Elbow | 9. Alternator | 16. Fuel Manifold | 23. Engine Block Drain |
| 3. Turbocharger | 10. Raw Water Pump | 17. Expansion Tank | |
| 4. Air Cleaner | 11. Lube Oil Dipstick | 18. Thermostat Cover | |
| 5. Fuel Filter | 12. Lube Oil Filter | 19. Heat Exchanger Zincs | |
| 6. Fuel Lift Pump | 13. Optional Hydrostatic Mount | 20. Heat Exchanger | |
| 7. Lube Oil Fill | 14. Starter | 21. Belt Guard | |

Component Locations

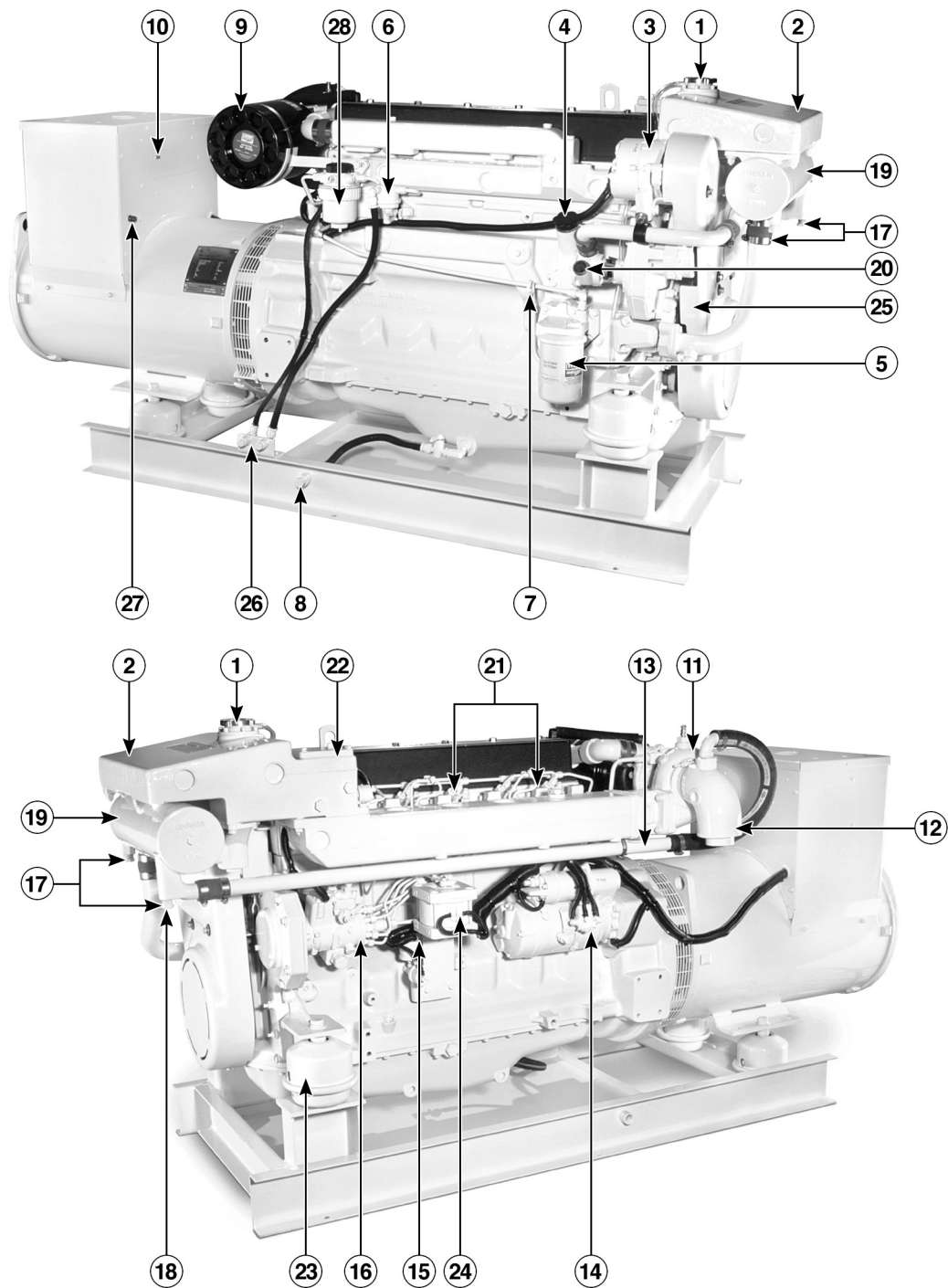

Figure 3 & 4: M1066T (Mechanically Controlled Fuel System)

- | | | | |
|----------------------|----------------------------|---------------------------------|--------------------------------|
| 1. Coolant Fill | 9. Air Cleaner | 17. Heat Exchanger Zinc (2) | 24. Optional Governor Actuator |
| 2. Expansion Tank | 10. DC Circuit Breaker | 18. Heat Exchanger Drain | 25. Drive Belt Cover |
| 3. DC Alternator | 11. Turbocharger | 19. Heat Exchanger | 26. Fuel Manifold |
| 4. Lube Oil Fill | 12. Wet Exhaust Elbow | 20. Raw Water Pump | 27. A.V.R. Fuse |
| 5. Lube Oil Filter | 13. Exhaust Manifold Drain | 21. Fuel Injectors (6) | 28. Fuel Filter |
| 6. Fuel Lift Pump | 14. Electric Starter | 22. Thermostat cover | |
| 7. Lube Oil Dipstick | 15. Engine Block Drain | 23. Optional Hydrolastic Mounts | |
| 8. Lube Oil Drain | 16. Fuel Injection Pump | | |

Component Locations

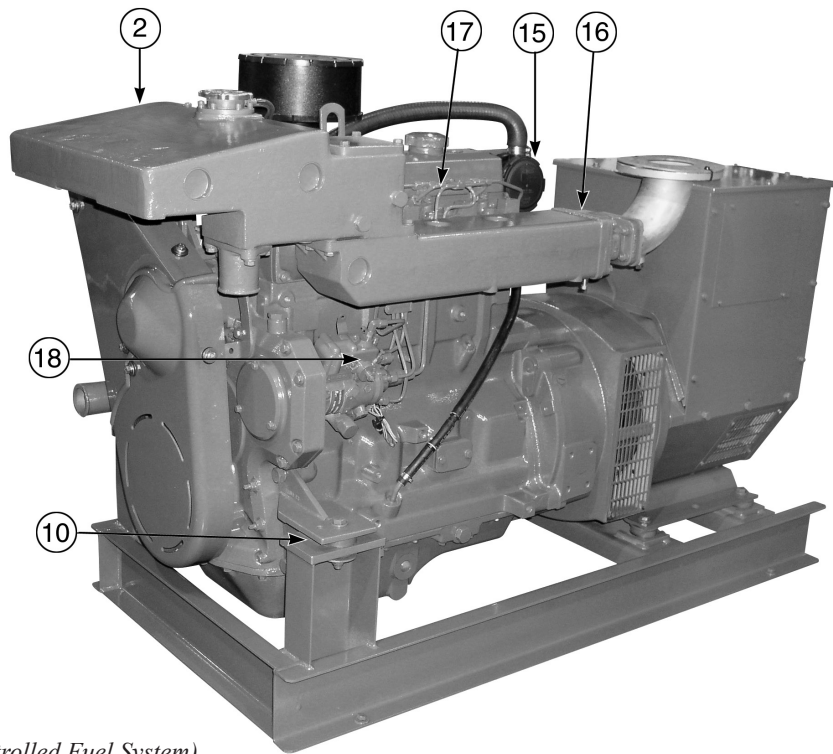
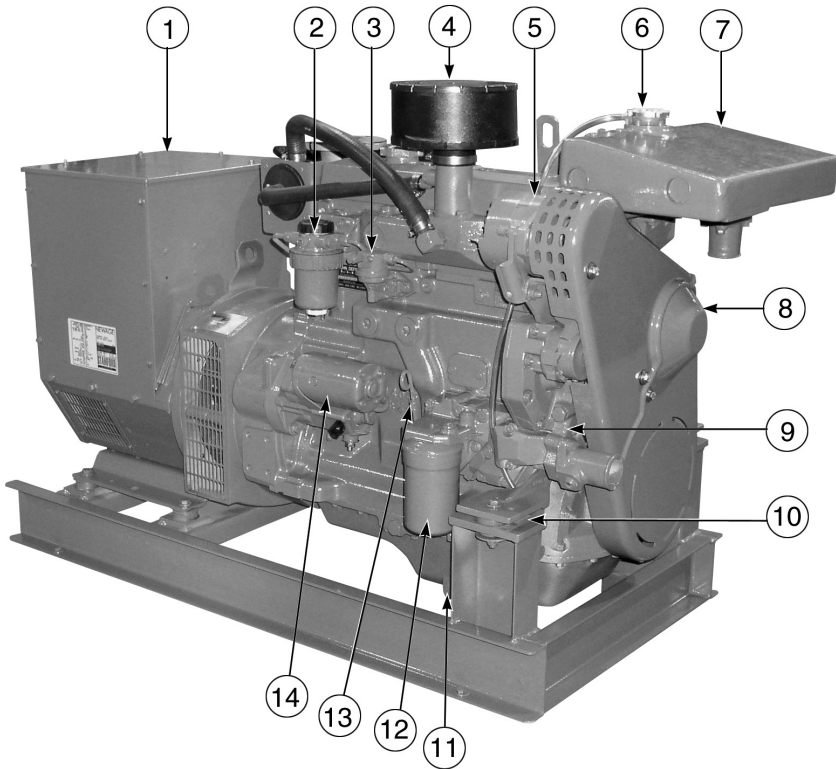

Figure 5 & 6: M40C2 (Mechanically Controlled Fuel System)

- | | | | |
|-------------------|-------------------------|---------------------------|-------------------------|
| 1. Junction Box | 6. Coolant Fill | 11. Lube Oil Drain | 16. Exhaust Manifold |
| 2. Fuel Filter | 7. Expansion Tank | 12. Lube Oil Filter | 17. Injection Lines |
| 3. Fuel Lift Pump | 8. Belt Guard | 13. Dipstick | 18. Fuel Injection Pump |
| 4. Air Cleaner | 9. Coolant Pump | 14. Electric Starter | |
| 5. Alternator | 10. Centerbonded Mounts | 15. Closed Crankcase Vent | |

Northern Lights Control Panels



Figure 7: Series 3B Generator Control Panel

- 1. SHUTDOWN BYPASS SWITCH**
This switch bypasses the safety shutdown feature during the starting process.
- 2. ENGINE CONTROL SWITCH**
To start the engine, hold this switch in the START position until the engine is running.
NOTE: Excessive cranking of marine sets equipped with water lift muffler systems can cause engine damage.
After the engine starts, release the switch and it will return to RUN position. To stop the engine, hold the switch in the STOP position.
- 3. OIL PRESSURE GAUGE**
The oil pressure gauge shows the oil pressure in the engine lubricating system. If the pressure drops below 15 PSI at a speed higher than idling, stop the engine and investigate.
- 4. COOLANT TEMPERATURE GAUGE**
Water temperature gauge shows the temperature of the cooling water. If the gauge registers over 200°F (93.3°C) or drops below 140°F (60°C), stop the engine and investigate.
- 5. HOUR METER**
Keeps track of the engine running time.
- 6. DC VOLTMETER**
When the engine is running, it indicates the voltage output of the alternator.

Northern Lights Control Panel



Figure 8: Series 4 B Generator Control Panel

1. SHUTDOWN BYPASS SWITCH

This switch bypasses the safety shutdown feature during the starting process.

2. ENGINE CONTROL SWITCH

The control switch starts and stops the engine.

3. OIL PRESSURE GAUGE

The oil pressure gauge shows the oil pressure in the engine lubricating system. If the pressure drops below 15 PSI at a speed higher than idling, stop the engine and investigate.

4. COOLANT TEMPERATURE GAUGE

Water temperature gauge shows the temperature of the cooling water. If the gauge registers over 200° (93.3°C) or drops below 140°(60°C), stop the engine and investigate.

5. HOUR METER

Keeps track of the engine running time.

6. DC VOLTMETER

When the engine is running, it indicates the voltage output of the alternator.

7. AC VOLTMETER

The voltmeter shows the generator output voltage, phase to phase. If the voltage fluctuates greatly from the normal reading, shut down the unit and investigate.

8. FREQUENCY METER

Indicates engine speed. The correct reading for 1800 and 1200 RPM sets is 60 Hz. For 1500 RPM sets, it is 50 Hz. If meter does not indicate correct hertz, stop and investigate.

9. AMMETER SELECTOR SWITCH

The ammeter switch is used for checking each phase for load condition. Leave it in the ON position while the engine is running.

10. AC AMMETER

The ammeter indicates the phase load. Check for load unbalance. If the unbalance is greater than 30%, have an electrician balance the load properly. This will ensure longer generator life and better economy.

Emission-Related Installation & Instructions

Failing to follow these instructions when installing a certified engine in a vessel violates federal law (40 CFR 1068.105(b)), subject to fines or other penalties as described in the Clean Air Act.

The installed exhaust system should not create exhaust back pressure greater than 30" (760 mm) of water for

a turbocharged engine and 48" (1200 mm) for a non-turbocharged unit, measured at the engine exhaust elbow.

If you install the engine in a way that makes the engine's emission control information label hard to read during normal engine maintenance, you must place a duplicate

Operating Procedures

BEFORE STARTING

1. Check the water level by removing the pressure cap from the expansion tank. In order to give the cooling water room to expand, the level should be about 1 3/4 in. (4-5 cm) below the filler cap sealing surface when the engine is cold. When filling with coolant, the venting cock on top of the turbocharger should be opened to ensure that no air pockets form in the cooling system (see Service Point #14).



CAUTION: Use protective clothing and open the filler cap carefully when the engine is warm to prevent burns.

2. Check the oil level in the crankcase with the dipstick. The oil level should be between the "waffled area" and the "oo". Never allow the level to go below the "oo". Always add the same viscosity of oil as is already in the crankcase (see Service Point #1).
3. Check the fuel tank level and open any fuel valves.
4. Disengage clutch, if equipped.
5. Close the seacock, check and clean the strainer and reopen the seacock.
6. Place the battery switch in the ON position.

NOTE: The battery switch must always be kept ON while the engine is running. If the switch is turned OFF while the engine is running, the battery charging regulator could be ruined.

Starting

1. While holding the Shutdown Bypass switch in the ON position, push the Engine Control switch to the START position.
2. As soon as the engine starts, release both switches. Do not crank the starter for more than 20 seconds.
3. If the engine fails to start the first time, be sure the starter has stopped before re-engaging.

NOTE: If there is a governor locked at a specific speed on the generator set, there may not be a slow idle function, so in that case operate the engine at high idle for 1 to 2 minutes before adding load. If the stand-by generator set is loaded as soon as it reaches rated speed, this procedure would not apply.

Operating

1. Check Gauges Often: Oil pressure must be above 29 PSI (if not above 15 PSI within 5 seconds of starting, the engine should be stopped and the problem should be explored). Normal oil pressure is 50 PSI at rated load speed (1800 to 2500 RPM). Oil temperature should be 115°C (240°F) for normal operating temperature. The D.C. voltmeter should read between 13 and 14 volts (26-28 volts, 24 volt systems).
2. Check AC voltage and frequency meters (Series 4 Panel). If gauges deviate from normal levels, shut down the set and investigate.
3. Check belt for good alignment.
4. Let the unit run unloaded for a three to five minute warm-up period before applying load.
5. Do not add full electrical load until engine is at maximum operating temperature.

Shutdown

1. Turn the Engine Control Switch to the OFF position.
2. Close the sea cock and fuel valves, and put the battery switch in the OFF position if the unit will be off for an extended period.

NOTE: Do not turn the battery switch to OFF while the engine is running.

Operating Procedures

SHUTDOWNS AND ALARMS

1. Your unit is fitted with a system to protect it from high water temperature or low oil pressure.
 - a. Generator sets have shutdown systems to stop the engine. They have no warning horns.
 - b. Other alarms and shutdowns are available as optional equipment.

NOTE: Do not rely on your warning or shutdown system to the exclusion of careful gauge monitoring. Watching your gauges can prevent damage to the unit and dangerous power losses.

2. Do the following when your shutdown system is activated:
 - a. Check the temperature gauge. If the temperature is above 205°F (97°C), shut off the engine immediately.
 - b. Use the Trouble Shooting Guide on pages 26- 28 to isolate the cause of the overheat.



CAUTION: Do not remove the water fill cap of an overheated engine. Escaping high temperature steam can cause severe burns. Allow the engine to cool and then remove the cap slowly, using protective clothing.

- c. Make repairs and restart after the temperature gauge registers below 180°F (83°C).
 - d. Watch the temperature gauge regularly and turn off the unit if the temperature rises above 200°F (93.3°C). Repeat the troubleshooting process.
3. If the shutdown is activated and the temperature gauge shows temperature within normal temperature range:
 - a. Check the engine crankcase oil level.
 - b. If the oil level is low, fill with recommended lubricating oil and restart. Watch the oil pressure gauge carefully and shut off the engine if it does not show a normal reading after a few seconds of operation.
 - c. If the oil level was normal, DO NOT restart the engine. Call your Northern Lights or Luggier dealer for assistance.

BREAK-IN PERIOD

1. Your engine is ready to be put into service. However, the first 100 hours on a new or reconditioned engine are critical to its life and performance. This is especially true of an engine that runs at a constant speed such as a generator engine.
2. Operate the engine under various conditions, particularly heavy loads with minimal idling, to help seat engine components properly.
3. Oil consumption is greater during break-in as piston rings take time to seat.
4. Your engine comes equipped with break-in oil. Change engine oil and filter at 50 hours using API Service Category CC, CD, or CE break-in oil. Change the oil and filter again at 100 hours. (Consult the lubricants section for oil recommendation.)
5. Frequently check the engine temperature and oil pressure gauges.

Service Schedule Chart, Mechanically Controlled Fuel System

The Servicing Schedule Chart below shows the service schedule required for proper maintenance of your marine generator set. More detailed coverage of each Service Point (SP) is listed on the page noted in the 'page' column.

DAILY:

- SP1 Check oil level in engine
- SP6 Check primary fuel filter
- SP14 Check cooling water level
- SP21 Check crankcase vent system filter svc. indicator button

AFTER FIRST 50 HOURS:

- SP2 Change engine oil
- SP3 Change lube oil filter

EVERY 50 HOURS:

- SP19 Check electrolyte in batteries

AFTER FIRST 100 HOURS/ EVERY TWO WEEKS ⁵:

- SP2 Change engine oil after first 100 hrs., then check every 2 wks.
- SP3 Change oil filter after first 100 hrs., then check every 2 wks.
- SP9 Check crankshaft vibration damper⁷
- SP14 Check coolant level

EVERY 250 HOURS :

- SP2 Change engine oil
- SP3 Change lube oil filter
- SP4 Check air cleaner
- SP17 Check zincs
- SP21 Check crankcase vent system, change element at 250 hrs.

EVERY 500 HOURS / YEARLY:

- SP4 Replace air cleaner
- SP6 Change primary filter element (Racor)
- SP8 Change secondary fuel filter
- SP10 Check injectors
- SP13 Check turbocharger boost pressure
- SP15 Check cooling system
- SP18 Change impeller in raw water pump
- SP19 Check the state of the charge of the batteries

EVERY 2000 HOURS:

- SP5 Check & adjust valve clearance
- SP9 Check crankshaft vibration damper
- SP11 Check fuel injection pump
- SP15 Flush cooling system

SERVICE POINT	PAGE	OPERATION	DAILY	50 Hours	100 Hours	250 Hours	500 Hours	2000 Hours
ENGINE:								
SP1	19	Check oil level	•					
SP2	19	Change engine oil 2)		1)	1)	•		
SP3	19	Change lube oil filters 2)		1)	1)	•		
SP4	19	Check air cleaner				•	•	
SP5	20	Check valve clearances 2)						•
SP9	22	Check crankshaft vibration damper 5)						•
SP21	31	Check crankcase vent system 2)	•			7)		
SP22	31	Check aftercooler, clean air side						•
FUEL SYSTEM:								
SP6	21	Check primary filter (Racor) 3)	•					
SP7	21	Change primary filter element (Racor) 3) 4)					•	
SP8	21	Change secondary fuel filter 2) 4)					•	
SP10	22-23	Check injectors 2)					•	
SP11	24-26	Check fuel injection pump						•
TURBOCHARGER:								
SP12	27	Check air, oil & cooling water lines for leakage 2)			•			
SP13	27	Check boost pressure					•	
COOLING SYSTEM:								
SP14	29	Check cooling water level	•					
SP15	29	Check and flush cooling system 2)					6)	•
SP16	29	Check and clean heat exchanger 2)						•
SP17	30	Check zinc electrodes 2) 4)				•		
SP18	30	Change impeller in raw water pump 2) 4)					•	
ELECTRICAL SYSTEM:								
SP19	31	Check electrolyte level in batteries 2) 4)		•				
SP20	31	Check condition of batteries with hydrometer 2)					•	

- 1) Change the oil and filter at 50 hours, using break-in oil again, until changing it at 100 hours, then at every 250 hours.
- 2) Perform all maintenance once a year even if hour level has not been reached.
- 3) Consult manufacturer's maintenance schedule.
- 4) Or whenever necessary.

- 5) Replace damper every 4500 hours or after 60 months.
- 6) Check cooling system at 500 hours, flush at 2000 hours.
- 7) Check hoses, and o-rings on crankcase vent system, change element at 250 hours.

Service Schedule Chart, Electronically Controlled Fuel System

The Servicing Schedule Chart below shows the service schedule required for proper maintenance of your marine generator set. More detailed coverage of each Service Point (SP) is listed on the page noted in the 'page' column.

DAILY:

- SP1 Check oil level in engine
- SP6 Check primary fuel filter
- SP14 Check cooling water level
- SP21 Check crankcase vent system filter svc. indicator button

AFTER FIRST 50 HOURS:

- SP2 Change engine oil
- SP3 Change lube oil filter

EVERY 50 HOURS:

- SP19 Check electrolyte in batteries

AFTER FIRST 100 HOURS/ EVERY TWO WEEKS ⁵:

- SP2 Change engine oil after first 100 hrs., then check every 2 wks.
- SP3 Change oil filter after first 100 hrs., then check every 2 wks.
- SP9 Check crankshaft vibration damper⁷
- SP14 Check coolant level

EVERY 250 HOURS :

- SP2 Change engine oil
- SP3 Change lube oil filter
- SP4 Check air cleaner
- SP17 Check zincs
- SP21 Check crankcase vent system, change element at 250 hrs.

EVERY 500 HOURS / YEARLY:

- SP4 Replace air cleaner
- SP6 Change primary filter element (Racor)
- SP8 Change secondary fuel filter
- SP10 Check injectors
- SP13 Check turbocharger boost pressure
- SP15 Check cooling system
- SP18 Change impeller in raw water pump
- SP19 Check the state of the charge of the batteries

EVERY 2000 HOURS:

- SP5 Check & adjust valve clearance
- SP9 Check crankshaft vibration damper
- SP11 Check fuel injection pump
- SP15 Flush cooling system

SERVICE POINT	PAGE	OPERATION	DAILY	50 Hours	100 Hours	250 Hours	500 Hours	2000 Hours
ENGINE:								
SP1	19	Check oil level	•					
SP2	19	Change engine oil 2)		1)	1)	•		
SP3	19	Change lube oil filters 2)		1)	1)	•		
SP4	19	Check air cleaner				•	•	
SP5	20	Check valve clearances 2)						•
SP9	22	Check crankshaft vibration damper 5)						•
SP21	31	Check crankcase vent system 2)	•			7)		
SP22	31	Check aftercooler, clean air side						•
FUEL SYSTEM:								
SP6	21	Check primary filter (Racor) 3)	•					
SP7	21	Change primary filter element (Racor) 3) 4)					•	
SP8	21	Change secondary fuel filter 2) 4)					•	
SP10	22-23	Check injectors 2)					•	
SP11	24-26	Check fuel injection pump						•
TURBOCHARGER:								
SP12	27	Check air, oil & cooling water lines for leakage 2)			•			
SP13	27	Check boost pressure					•	
COOLING SYSTEM:								
SP14	29	Check cooling water level	•					
SP15	29	Check and flush cooling system 2)					6)	•
SP16	29	Check and clean heat exchanger 2)						•
SP17	30	Check zinc electrodes 2) 4)				•		
SP18	30	Change impeller in raw water pump 2) 4)					•	
ELECTRICAL SYSTEM:								
SP19	31	Check electrolyte level in batteries 2) 4)		•				
SP20	31	Check condition of batteries with hydrometer 2)					•	

1) Change the oil and filter at 50 hours, using break-in oil again, until changing it at 100 hours, then at every 250 hours.
 2) Perform all maintenance once a year even if hour level has not been reached.
 3) Consult manufacturer's maintenance schedule.
 4) Or whenever necessary.

5) Replace damper every 4500 hours or after 60 months.
 6) Check cooling system at 500 hours, flush at 2000 hours.
 7) Check hoses, and o-rings on crankcase vent system, change element at 250 hours.

Servicing

LUBRICATION

Break-in oil

1. Use one of the following during the first 100 hours of operation:
 - a. John Deere Engine Break-In Oil
 - b. API Service Category CC, CD, or CE oil
 - c. ACEA Specification E1
2. Do not use John Deere PLUS-50 oil or engine oils meeting API CG4, API CF4, ACEA E3, or ACEA E2 performance levels during the first 100 hours of operation of a new or rebuilt engine. These oils will not allow the engine to break-in properly.

Lubrication - General

1. Use only clean, high quality lubricants stored in clean containers in a protected area.
2. These oils are acceptable after the first 100 hours:
 - a. ACEA Oil Sequence E5 and E4
 - b. API Service Category CI-4 or CH-4.
 - c. ACEA Oil Sequence E3 multi-viscosity oil.
3. Use the proper weight oil for your average operation temperature.

Air Temperature	Single Viscosity	Multi Viscosity
Above 32°F (0°C)	SAE-30W	SAE15-40W
-10°F to 32°F (-23°C to 0°C)	SAE-10W	SAE10-30W
Below -10°F (-23°C)	SAE-5W	SAE5-20W

4. Some increase in oil consumption may be expected when SAE 5W and SAE 5-20W oils are used. Check oil level frequently.
5. Never put additives or flushing oil in crankcase.

SP-1. CHECK ENGINE OIL LEVEL

1. Check the oil level in the crankcase, with the oil dipstick, daily.
2. The oil level must be between the “Waffled area” and the “oo”. Never allow the level to go below the “oo”.
3. Always add the same viscosity of oil as is already in the crankcase.

SP-2. OIL CHANGES

1. Using the oil recommended above, change the engine oil and filter after the first 50 hours of operation, the first 100 hours and every 250 hours thereafter.

SP-2. OIL CHANGES *continued*

2. During intermittent cold weather operation, change oil every 100 hours or six weeks, whichever comes first.
3. Change oil at any seasonal change in temperature when a new viscosity of oil is required.
 - a. Remove plug from outlet in base frame. Screw in owner-supplied drain hose.
 - b. Open valve at oil pan outlet. After oil has been drained into suitable container, close valve, remove drain hose and replace plug in base frame outlet.
 - c. Refill engine with recommended oil.
4. Engine Lube Oil Capacity:

M1064D & T1	15.5 qts.	14.7 liters
M1064T2 (@60 Hz)	15.5 qts.	14.7 liters
M1064T2 (@50 Hz)	21.6 qts.	20.5 liters
M1064A & H	21.6 qts.	20.5 liters
M40C2	15.5 qts.	14.7 liters
M55C2	15.5 qts.	14.7 liters
M65C2	15.5 qts.	14.7 liters
M1066T	20.0 qts.	19.0 liters*
M1066A1, A2, A3	34.3 qts.	32.5 liters
M99C2	20.0 qts.	19.0 liters

*depending on oil pan size

SP-3. CHANGING OIL FILTER

1. Change the lube oil filter every 250 hours, after the initial 50 and 100 hour change.
2. Use a filter wrench to remove old filter. Dispose of filter in approved manner.
3. Make sure the gasket from the old filter is removed and discarded.
4. Lubricate the rubber gasket on the new filter and screw it on nipple until gasket meet the sealing surface.
5. Using hands only, no wrench, tighten filter one-half turn farther. Overtightening can do damage to filter housing.
6. Fill engine with recommended oil. Start engine and check for leakage. Stop engine and check oil level. Add additional oil if necessary.

SP-4. AIR CLEANER

1. Inspect air cleaner every 100 hours. Replace filter every 500 hours, or yearly, whichever comes first for mechanically controlled fuel system engines. For electronically controlled units - replace air cleaner element every 500 hours.
2. Clean the rubber tube at the cleaner. Loosen the hose clamp and the attaching strip for the cleaner.
3. Make sure the rubber tube is in good condition and that new filter is absolutely clean and installed properly.
4. Start the engine and check for leaks.

NOTE: Make absolutely sure no impurities enter the engine while changing the element. Do not run the engine with the air cleaner removed.

Servicing

SP-5. VALVE CLEARANCES

The following special tools will be needed:

JDE 820 or JDE 83 Flywheel Turning Tool,
JDE 81-4 Timing Pin.

1. Remove rocker arm cover with ventilator tube.
2. Remove plastic plugs in engine timing holes on front side of flywheel.
3. Rotate flywheel in clockwise direction (viewed from water pump) with the Flywheel Turning Tool until the Timing Pin engages timing hole in the flywheel. Both rocker arms for No. 1 cylinder will be loose at Top Dead Center. If they are not, remove the timing pin and rotate the flywheel one complete turn and reinstall the timing pin in the flywheel.
4. Valve clearances must be checked with the engine cold.
Intake Valve: 0.012-0.015 in. (0.31-0.38 mm)
Exhaust Valve: 0.016-0.019 in. (0.41-0.48 mm)
5. If the valves need adjusting, loosen the jam nut (A on Figure 9) on the rocker arm adjusting screw. Turn the adjusting screw until you feel a slight drag when the feeler gauge slips. With a screwdriver, hold the adjusting screw from turning while tightening the jam nut to specifications. Check the clearance again after tightening the jam nut. Re-adjust as needed.

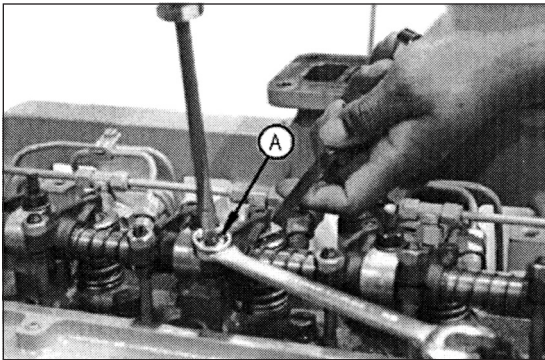

Reproduced by permission of Deere & Company, c2004. Deere & Company. All rights reserved. RG7409

Figure 9

4-CYLINDER ENGINES:

Lock No. 1 piston at TDC compression stroke (B). Adjust valve clearance on No. 1 and No. 3 exhaust valves and No. 1 and No. 2 intake valves. Rotate flywheel 360°. Lock No. 4 piston at TDC compression stroke (C).

NOTE: Firing order is 1 - 3 - 4 - 2

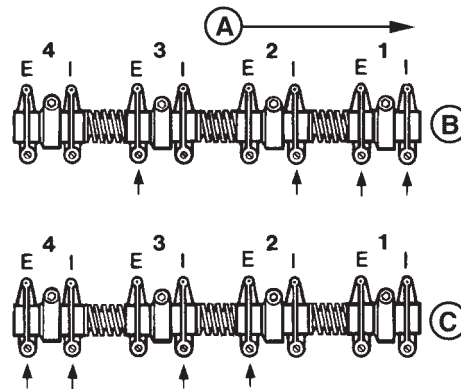

Reproduced by permission of Deere & Company, c2004. Deere & Company. All rights reserved. RG4776 Figure 10

- A - Front of Engine
- B - No. 1 Piston at TDC Compression Stroke
- C - No. 4 Piston at TDC Compression Stroke
- E - Exhaust Valve
- I - Intake Valve

Adjust valve clearance on No. 2 and No. 4 exhaust valves and No. 3 and No. 4 intake valves.

6-CYLINDER ENGINES:

NOTE: Firing order is 1 - 5 - 3 - 6 - 2 - 4

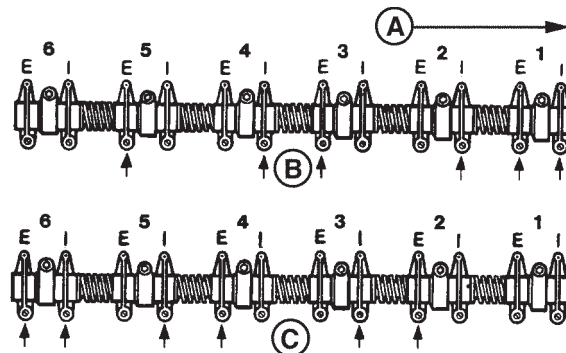

Reproduced by permission of Deere & Company, c2004. Deere & Company. All rights reserved. RG4777

Figure 11

- A - Front of Engine
- B - No. 1 Piston at TDC Compression Stroke
- C - No. 6 Piston at TDC Compression Stroke
- E - Exhaust Valve
- I - Intake Valve

Lock No. 1 piston at TDC compression stroke (B). Adjust valve clearance on No. 1, No. 3, and No. 5 exhaust valves and No. 1, No. 2, and No. 4 intake valves. Rotate flywheel 360°. Lock No. 6 piston at TDC compression stroke (C). Adjust valve clearance on No. 2, No. 4, and No. 6 exhaust valves and No. 3, No. 5, and No. 6 intake valves.

Servicing

FUELS - GENERAL

1. Use only clean, high quality fuels of the following specifications, as defined by ASTM designation D975 for diesel fuels:
 - a. Use Grade No. 2 diesel at ambient temperatures above freezing 30°F (0°C).
 - b. Use Grade No.1 at ambient temperatures below freezing and for all temperatures at an altitude of above 5,500 ft. (1500 meters).
2. Sulphur content should not exceed 0.5% (preferably less than 0.5%).
3. The cetane number should be a minimum of 45.
4. DO NOT use these unsuitable grades of fuel:
 - a. Domestic heating oils, all types,
 - b. Class B engine,
 - c. Class D domestic fuels,
 - d. Class E, F, G or H industrial or marine fuels,
 - e. ASTM-D975-60T No. 4-D and higher number fuels,
 - f. JP4
5. Storing fuel:
 - a. Keep dirt, scale, water and other foreign matter out of fuel.
 - b. Avoid storing fuel for long periods of time.
 - c. Fill the fuel tank at the end of each day's operation. This will reduce condensation.
6. Biodiesel:

Biodiesel involves the transesterification of vegetable oils or animal fats. Mainly in the U.S. soybean methyl ester is used (SME), but in Europe mainly rapeseed (canola) methyl ester is made (RME), and in Asia palm methyl ester is made (PME). 100% biodiesel (B100) is made in compliance with ASTM D6751 or EN14214 (EU) specifications. Biodiesel may be used in a 5% blend (5% biodiesel/ 95% diesel) from a BQ-9000 accredited producer. 20% biodiesel blends can only be used if they meet ASTM D6751 or EN14214 (EU) specifications. A 2% reduction in power and a 3% reduction in fuel economy can be expected using a 20% blend, and a fuel conditioner is recommended. Biodiesel blends must be used within 90 days of their manufacture. Oil level, leaking, microbial growth, plugging, and component degradation all must be checked more frequently using biodiesel blends. Request a certificate of analysis from an approved biodiesel fuel distributor to make sure the blend meets specifications.

NOTE: Using raw pressed or partially refined vegetable oils or recycled greases as fuel (which have not been through transesterification) could cause engine failure.

FUEL FILTERS

1. Your engine or generator set should have a primary fuel filter installed. We recommend the Racor brand of fuel filter - water separators.

SP-6. PRIMARY FUEL FILTER

- a. Check the primary fuel filter daily as recommended by the filter manufacturer. Empty the collection bowl as necessary.

SP-7. PRIMARY FUEL FILTER ELEMENT

- b. Change the element every 250 hours (500 for electronically controlled fuel system units) or whenever necessary.
- c. If the bowl fills with water, change the primary and secondary elements immediately.

SP-8. SECONDARY FUEL FILTER

Change secondary fuel filter every 500 hours.

NOTE: The fuel filter on the engine is considered the "secondary fuel filter". The engine will be fitted with a quick change disposable secondary fuel filter.

- a. Turn off the fuel.
- b. Open the filter drain plug (Figure 12-A) and drain the filter.

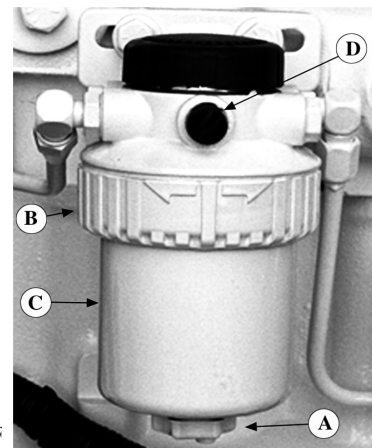

A - Drain Plug
B - Filter Clamp
C - Cartridge
D - Bleed Screw

- c. Remove the secondary fuel filter by turning the filter clamp (Figure 12-B) counter clockwise until the filter cartridge (Figure 12-C) slides out.

NOTE: Before installing a new filter cartridge make sure the surfaces where the cartridge comes in contact with the mounting plate are absolutely clean. Dirt can be washed into the fuel injection system. This may result in severe damage to the fuel injection pump or nozzles. Your generator set may have two secondary filters, depending on the fuel supply system. **Do not "prefill" the new fuel filter as the fuel used may be contaminated and damage the fuel system components.**

- d. Install new filter cartridge.
- e. Turn on the fuel.

Servicing

BLEEDING THE FUEL SYSTEM



CAUTION: Escaping diesel fuel under pressure can penetrate the skin, causing serious personal injury. Before disconnecting lines be sure to relieve all pressure. Before applying pressure to the system be sure all connections are tight and the lines, pipes and hoses are not damaged. Fuel escaping from a very small hole can be almost invisible. Use a piece of cardboard or wood rather than the hands to search for suspected leaks. If injured by escaping fuel, see a doctor at once. Serious infection or reaction can develop if proper medical treatment is not administered immediately.

1. Whenever the fuel system has been opened for service, (lines disconnected, filter changed, etc.) it will be necessary to bleed air from the system.
 - a. To bleed the fuel system, loosen the bleed plug on the fuel filter.

Operate the primer pump lever on fuel transfer pump (see component locations) until most of the air bubbles are expelled and clear fuel escapes the bleed plug. Tighten the bleed plug.
 - b. If the engine will not start, it may be necessary to loosen the fuel supply pipe at the pump. Operate primer lever of fuel supply pump until fuel flow is free from air bubbles. Retighten fuel supply line to 22 ft. lb. (30 N•m).
 - c. If engine still doesn't start, loosen fuel line connection at injection nozzle. Always use a back up wrench when loosening or tightening fuel lines at nozzles and injection pump to avoid damage. With throttle on full, crank the engine over with the starter until fuel without air flows from the loose fuel pipe connection. Repeat procedure for remaining nozzles, if necessary, until engine starts or until air has been removed from system. Tighten the connections to 20 foot lb. (27 N•m).
 - d. For models M1066A2 and M1066A3 bleed the fuel system using the electronic transfer pump. The ignition should be on and allow 40 seconds for the pump to complete the priming. If additional system bleeding is needed, do it by loosening the fuel line connections at the injection nozzles.

SP-9. CRANKSHAFT VIBRATION DAMPER (6 Cylinder Engines Only)

1. Remove belts.
2. Try to turn the vibration damper in both directions while grasping it with both hands. If rotation can be felt, the damper is defective and should be replaced.

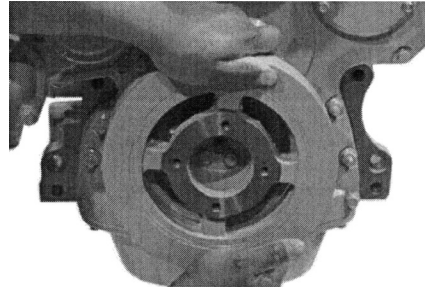

Reproduced by permission of Deere & Company, c2004. Deere & Company. All rights reserved. RG8018

Figure 13

NOTE: The vibration damper assembly should be replaced every 4500 hours or 60 months, whichever occurs first, as the vibration damper assembly is not repairable.

3. Place a dial indicator (Figure 13) so that the probe contacts the damper's outer diameter in order to check the damper radial run out.
4. Make sure the engine is at operating temperature, then rotate the crankshaft using the JD281A, JDE81-4, or the JDE83 Flywheel Turning Tool.
5. If the runout reading exceeds the below specification, replace the vibration damper.
Vibration Damper Maximum
Radial Runout1.50 mm (0.060 in.)

SP-10. INJECTORS

1. Fuel injectors should be checked by a Luggen-Northern Lights dealer or qualified fuel injection shop every 500 hours.
2. Injector Removal:

You will need the following special tools:
JDE38A-Injection Nozzle Puller
JDE39-Nozzle Bore Cleaning Tool, JD258-Pilot Tool

 - a. Before removal, carefully remove all dirt from the cylinder head around fuel injection nozzles. Clean with compressed air to prevent dirt from entering the cylinders or valve seats. Plug the bore in the cylinder head after each fuel injection nozzle has been removed. Cap fuel line openings as soon as they are disconnected.
 - b. Immediately fit protective caps over the nozzle tips and the line connections to avoid handling damage.

Servicing

- c. Do not bend the fuel delivery lines. When loosening the fuel pressure lines, hold male union of nozzle line stationary with a backup wrench.
- d. Loosen nuts to remove leak-off lines and T-fittings and disconnect fuel injection line from nozzle.

NOTE: When all fuel injection nozzles have to be removed, disconnect leak-off line assembly at fuel tank, at injection pump, and at each nozzle T-fitting. Lift off complete leak-off line as an assembly.

- e. Remove cap screw, clamp and spacer.
- f. Pull injection nozzle out of cylinder head with JDE38A Injection Nozzle Puller.

NOTE: Do not use screwdrivers, pry bars, or similar tools for this as they might damage the injection nozzle.

3. Clean Injector Bore:

Always turn the tool clockwise through the bore even when removing from bore, otherwise tool may become dull.

- a. Clean nozzle bore with JDE39 Nozzle Bore Cleaning Tool. Blow debris from bore with compressed air and plug the bore to prevent entry of foreign material.

4. Clean injection nozzles:

- a. Remove carbon stop seal (Figure 14-A) and upper sealing washer (Figure 14-B), using a needle-nose pliers. Discard seals.
- b. Clean exterior of nozzle by soaking in clean solvent or diesel fuel. Clean tip with brass wire brush.

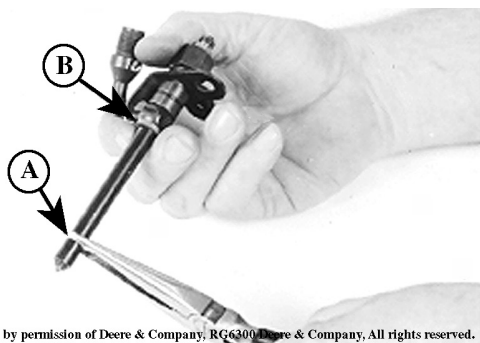

Reproduced by permission of Deere & Company, RG6300 Deere & Company, All rights reserved.

Reprinted by permission of Deere & Company, 2004. All rights reserved. RG6300

Figure 14

NOTE: Do not scrape or disturb the teflon coating on the nozzle body above the carbon stop seal groove.

This coating will become discolored during normal operation, but this is not harmful. Do not use a motor driven brush to clean up nozzle body.

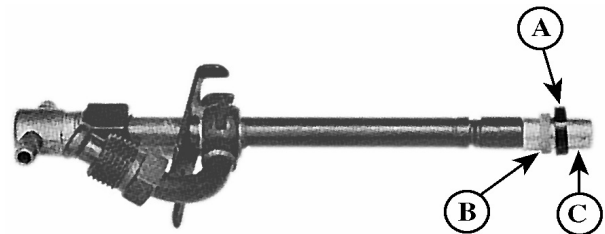

Figure 15

5. Install seals on injection nozzle.

NOTE: Each time an injection nozzle is removed from the cylinder head, replace carbon stop seal (B) with a new one.

- a. Position JD258 (ROS16477) Pilot Tool (Figure 15-C) over nozzle tip. If Pilot Tool (included in cleaning kit) is not available, use a No. 16189 Nozzle Protector Cap found on every new or replacement nozzle.
- b. Position a new carbon stop seal (Figure 16-B) on pilot tool. Use a new seal washer (Figure 16-A) to help slide the carbon seal into place until it seats in its groove on nozzle body.
- c. Continue to slide upper sealing washer onto nozzle body until it seats against inlet fitting.

6. Install injection nozzles:

NOTE: Before installing injection nozzles, make sure nozzles are clean and free from oil or grease. Do not grease or oil the nozzles.

- a. Remove plug (if installed previously) from nozzle bore in cylinder head and blow out bore with compressed air.
- b. Make sure that the sealing surface of the cylinder head (on which the seal washer will be resting) is smooth and free of damage or dirt. This could prevent proper sealing. Dirt and roughness could also cause distortion to nozzle when the attaching screw is tightened, making the valve stick.
- c. Install nozzle in cylinder head using a slight twisting motion as nozzle is seated in bore.
- d. Install spacer and cap screw. Do not tighten capscrew at this stage.

Servicing

Install injection nozzles (continued):



Figure 16: Shows relationship of parts required for installation.

- e. Connect fuel pressure line to nozzle. Leave connection slightly loose until air is bled from system.
- f. Tighten nozzle hold-down cap screws to 27 foot lb. (37 N•m).
- g. Install leak-off assembly.
- h. Bleed air from loose injection line connection. Tighten connection using two wrenches.

SP-11. INJECTION PUMP

1. Since operating conditions may vary considerably, it is difficult to give a definite service interval. But, as a rule, the pump settings, maximum speed, idle speed and exhaust smoke should be checked by your dealer after every 2000 hours of operation. Service of the fuel injection pump should only be done if checks indicate pump malfunction.
2. Black smoke can be an indication of pump malfunctions. Before servicing pump, check the other possible causes.
 - a. Check cleanliness of air filter.
 - b. Check valve clearances.
 - c. Clean and check injectors.
3. Any repair which involves disassembly of the injection pump must be carried out by specially-trained mechanics with the proper tools and test devices.

NOTE: All warranties on the engine become null and void if the injection pump seals are broken by unauthorized persons.

DB4 AND DB2 INJECTION PUMPS – REMOVAL

All Stanadyne DB2 and DB4 injection pumps will have a retained drive shaft (shaft stays in pump when pump is removed from engine).

1. Clean the fuel injection pump, lines, and area around the pump with cleaning solvent or a steam cleaner.

IMPORTANT: Never steam clean or pour cold water on a fuel injection pump while the pump is running or while it is warm. Doing so may cause seizure of internal rotating pump parts.

2. Disconnect shutoff cable and speed control linkage or cold start switch, if equipped. Disconnect electrical connection to shutoff solenoid or throttle positioning solenoid. Tag electrical wires for correct reassembly.

IMPORTANT: Always use a backup wrench when loosening or tightening fuel lines at injection pump so that discharge fittings are not altered which will prevent internal pump damage.

3. Disconnect fuel return line and fuel supply line (Figure 17).

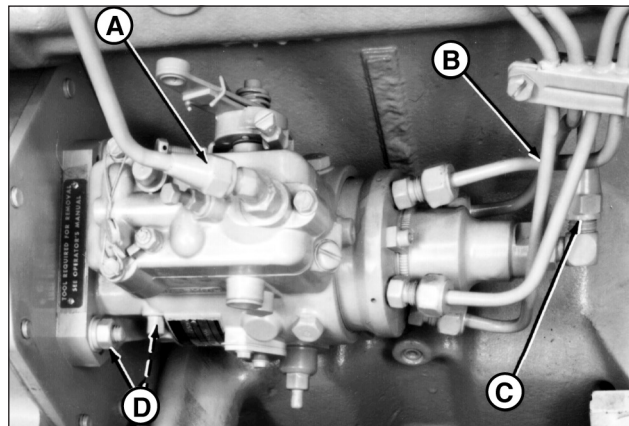

Figure 17 Reproduced by permission of Deere & Company, c.2004. Deere & Company. All rights reserved.

RG5659

4. Disconnect all fuel delivery (pressure) lines from injection pump using a suitable 17 mm deep-well crowsfoot socket.
5. Remove injection pump drive gear cover. Remove drive gear retaining nut and washer from end of pump shaft. Be careful not to let washer fall inside timing gear cover.

Servicing

NOTE: The injection pump drive gear fits snugly onto a tapered drive shaft and indexed by a hollow pin or Woodruff key installed in drive shaft.

6. Attach JDG670A Drive Gear Puller (Figure 19-A) to injection pump drive gear as shown.
NOTE: Replace 6mm Grade 12.9 cap screws (C) as needed.
7. Evenly tighten the two 6mm, Grade 12.9 screws (threaded in drive gear) and snugly tighten center forcing screw (Figure 18) against end of pump shaft.

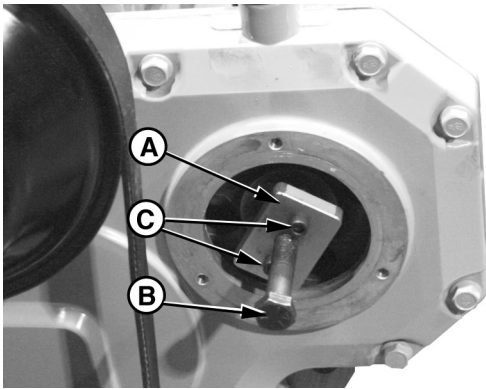

Figure 18 Reproduced by permission of Deere & Company, c.2004. Deere & Company. All rights reserved.
RG7757

8. Tighten center forcing screw until pump drive gear is free from tapered shaft. Remove JDG670A puller (Figure 18-A) and screws from drive gear.
9. Check to make sure that timing marks on back side of front plate (Figure 19-A) and injection pump flange (Figure 19-B) are present and properly aligned. This assures that repaired or replacement pump can be properly timed to engine when installed.

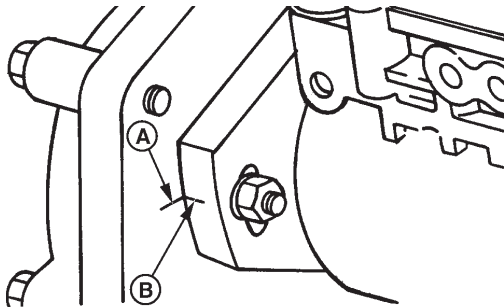

Figure 19 Reproduced by permission of Deere & Company, c.2004. Deere & Company. All rights reserved.
RG6293

IMPORTANT: Injection pump mounting flange timing mark (Figure 19-A) and front plate timing mark (Figure 19-B) presence and alignment MUST be verified before removing pumps from engine. DO NOT reference internal timing marks (on pump cam ring and governor weight retainer). If timing mark is not clearly visible on front plate, make a visible reference mark as accurately as possible in-line with mark on pump flange.

10. Remove three injection pump mounting stud nuts. Remove injection pump from mounting studs.
11. Plug or cap all openings on injection pump and take pump to dealer for service

DB4 & DB2 INJECTION PUMP – INSTALLATION

1. Lubricate a new square sealing ring with clean engine oil. Install ring into groove on front face of pump mounting flange. Slide injection pump onto mounting studs while inserting pump shaft into drive gear.
2. Check pump shaft and index pin for proper alignment with pump drive gear key slot.

IMPORTANT: Shaft roll pin may be easily damaged if improperly assembled. Pump drive gear should not move when initially installing pump index pin into drive gear key slot.

3. Install injection pump partially onto mounting studs without engaging pump pilot hub into engine front plate.

IMPORTANT: DO NOT tighten hex nuts more than three full turns on mounting studs. Pump drive shaft index pin may be damaged if pin is not properly aligned with drive gear key slot and if the nuts are tightened more than three turns.

4. Install three flat washers, lock washers, and hex nuts onto pump mounting studs. Tighten nuts three turns only so that pump will not fall off mounting studs.

NOTE: The pump drive gear should begin to move forward (away from engine front plate) with the pump when flange is approximately 1/8 in. (3.2 mm) away

Servicing

5. Install pump mounting flange flush to engine front plate with drive gear held flush against front side of engine front plate.
IMPORTANT: Do not use tightening force of pump mounting stud nuts to pull pump shaft into drive gear I.D.
6. With the pump shaft index pin properly engaged in the drive gear key slot, finger tighten mounting stud nuts.
7. Push pump drive gear firmly onto shaft taper. Install washer and retaining nut (Figure 20-C) onto end of shaft. Tighten retaining nut to 90 lb-ft. (122 N•m) for DB2, 150 lb-ft. (203 N•m) for DB4.

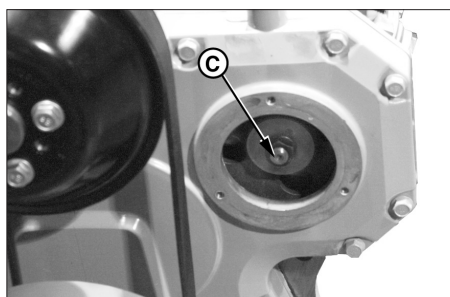

Figure 20 Reproduced by permission of Deere & Company, c.2004. Deere & Company, All rights reserved.
RG7630

IMPORTANT: Do not overtighten cap screws on pump cover plate to avoid damage to O-ring.

8. Install access cover plate using a new gasket. Apply LOCITE 242 (TY9370) to cap screw threads and tighten to 1.7 lb-ft. (2 N•m).
9. Align timing mark on the pump flange (Figure 21-B) with timing mark on the cylinder block front plate (A).

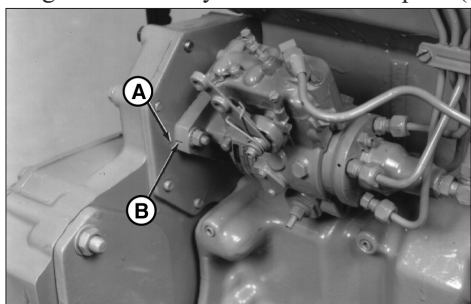

Figure 21 Reproduced by permission of Deere & Company, c.2004. Deere & Company, All rights reserved.
RG6278

10. Tighten the three hex nuts securing the pump to the front plate to 20 foot lbs. (27 N•m).
11. Connect injection pump pressure lines (Figure 22-E). Beginning with outlet connection to #1 cylinder (Figure 24-B) and continue around the pump head in counter-clockwise direction, attaching lines in same order as engine firing (1-5-3-6-2-4 on 6-cylinder engines and 1-3-4-2 on 4-cylinder engines).

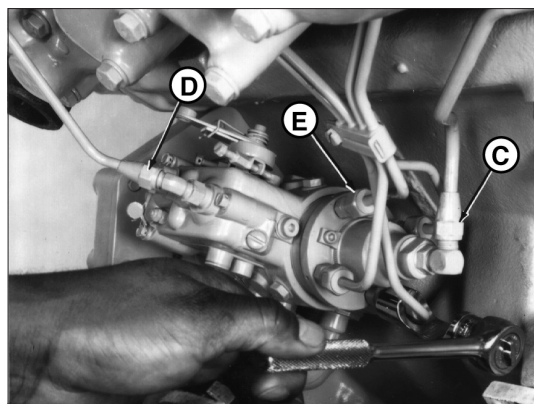

Figure 22 Reproduced by permission of Deere & Company, c.2004. Deere & Company, All rights reserved.
RG5664

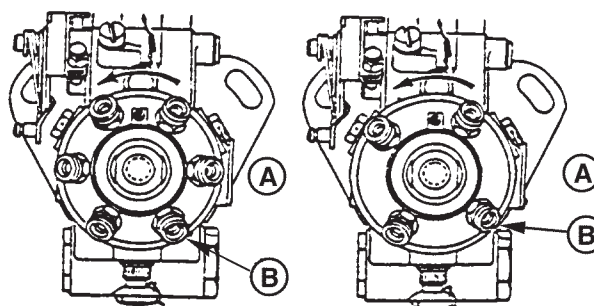

Figure 23 Reproduced by permission of Deere & Company, c.2004. Deere & Company, All rights reserved.
RG9089

12. Tighten fuel delivery (pressure) lines to 20 foot lbs. (27 N•m), using a suitable 17 mm deep-well crows-foot socket.

IMPORTANT: Always use a backup wrench when loosening or tightening fuel delivery lines at fuel injection pump, so that the pump discharge fittings are not altered. This prevents possible internal pump damage.

13. Connect fuel supply line (Figure 22-C) and fuel return line (Figure 22-D).
14. Connect fuel shutoff cable and speed control linkage, if equipped. Install and securely tighten electrical connections to shutoff solenoid and throttle positioning solenoid, if equipped. Connect cold start switch, if equipped.
15. Bleed air from fuel system as outlined on page 18. Start engine and run for several minutes. Check the entire system for leaks.

Servicing

SP-12. TURBOCHARGER

1. Check for air leaks every 100 hours. Air leakage will lower engine output and may cause black exhaust smoke and soot.
2. Listen along air line while engine is running. A whistling or hissing sound indicates leakage.
3. Leakage on the pressure side, between turbo and engine, can be found by applying soapy water to the air line.
4. Tighten the hose clamps, replace hose or gaskets as required.
5. Check to see that the lubrication and cooling lines are tight and without leaks.

SP-13. TURBO BOOST

1. This check measures the amount of air the turbo is pushing into the engine. It should be done by an authorized dealer every 500 hours.
2. On the inlet manifold there is a 1/8" NPT threaded port. Remove the plug and install the boost gauge hose. Refer to your engine specifications for correct pressure.

COOLING REQUIREMENTS

1. To meet cooling system protection requirements, the coolant solution must consist of:
 - a. Quality water
 - b. Ethylene glycol concentrate (EGC) commonly known as antifreeze.
 - c. Supplemental coolant additives (SCA's).
2. A coolant solution of ethylene glycol concentrate (EGC-antifreeze), quality water and supplemental coolant additives (SCA's) MUST be used YEAR ROUND to protect against freezing, boil-over, liner erosion or pitting and to provide a stable, noncorrosive environment for cooling system components.
3. Ethylene glycol coolant concentrate (antifreeze) normally DOES NOT contain the SCA chemical inhibitors needed to control liner pitting or erosion, rust, scale, and acidity.

LINER EROSION (PITTING)

1. Cylinder liner walls (Figure 24-A) which are in contact with engine coolant (Figure 24-B) can be eroded or pitted unless the proper concentration and type of SCA's are present in the coolant. Water pump impellers are also susceptible to pitting.

2. Vapor bubbles (Figure 25-C) are formed when the piston's impact causes the liner walls to vibrate, sending pressure waves into the coolant.
3. These tiny vapor bubbles collect on the surface of metal parts. As the bubbles collapse (pop) a microscopic piece of metal is eroded from the metal part. Over a period of time, this pitting may progress completely through the cylinder liner of a wet-sleeve, heavy-duty diesel engine. This allows coolant to enter the combustion chamber. Engine failure or other serious damage will result.

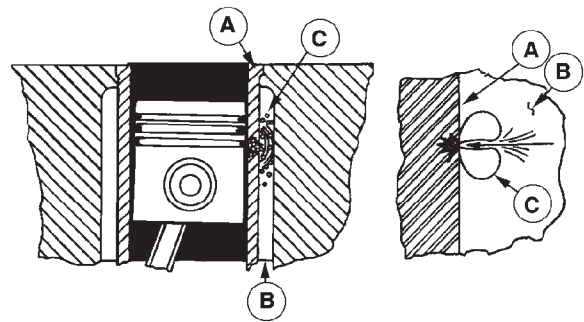

A - Cylinder Liner Walls B - Engine Coolant C - Vapor Bubbles

Figure 24

4. Unprotected engines with low quality water as coolant can have liner failure in as few as 500 hours.

WATER QUALITY

1. Distilled, deionized, soft water is preferred for use in cooling systems. Bottled distilled water from a food store or water supplier is recommended. Tap water often has a high mineral content. Tap water should NEVER be put in a cooling system unless first tested by a water quality laboratory. Do not use water made by the reverse osmosis method unless it has been PH neutralized.
2. Here are acceptable water quality specifications:

Contaminates	Parts per Million	Grains per Gallon
Maximum Chlorides	40	2.5
Maximum Sulfates	100	5.9
Maximum Dissolved Solids	340	20.0
Maximum Total Hardness	170	10.0
PH Level 5.5 to 9.0		

Servicing

3. If chlorides, sulfates or total dissolved solids are higher than the above given specification, the water must be distilled, demineralized, or deionized before it is used in a cooling system.
4. If total hardness is higher than 170 ppm and all other parameters are within the given specifications, the water must be softened before it is used to make coolant solution.

EGC: ETHYLENE GLYCOL CONCENTRATE (ANTIFREEZE)



CAUTION: EGC (Antifreeze) is flammable. Keep it away from any open flame. Avoid contact with eyes. Avoid contact with skin. Do not take internally. In case of contact, immediately wash skin with soap and water. For eyes, flush with large amounts of water for at least 15 minutes. Call a physician. **KEEP OUT OF REACH OF CHILDREN.** Follow all warnings on the container.

1. Ethylene glycol coolant concentrate is commonly mixed with water to produce an engine coolant with a low freeze point and high boiling point.
2. A low silicate form of ethylene glycol coolant is recommended for all diesel engines.
3. Use an ethylene glycol coolant concentrate meeting ASTM D 4985P, SAEJ1941, General Motors Performance Specification GM1899M, or formulated to GM6038M.
4. This product is concentrated and should be mixed to the following specification.
5. If additional coolant solution needs to be added to the engine due to leaks or loss, the glycol concentration should be checked with a hydrometer to assure that the desired freeze point is maintained.

	Distilled Water %	EGC % Antifreeze	Freeze Point	Boiling Point
Optimum	50%	50%	-37°C -34°F	+109°C +226°F
Minimum	60%	40%	-24°C -12°F	+106°C +222°F
Maximum	40%	60%	-52°C -62°F	+111°C +232°F

IMPORTANT

1. DO NOT use methyl alcohol or methoxy propanol base EGC. These concentrates are not compatible with chemicals used in supplemental coolant additives. Damage can occur to rubber seals on cylinder liners which are in contact with coolant.
2. DO NOT use an EGC containing sealer or stop-leak additives.
3. DO NOT use EGC containing more than 0.1% anhydrous metasilicate. This type of concentrate, which is intended for use in aluminum engines, may cause a gel-like deposit to form that reduces heat transfer and coolant flow. Check container label or consult with supplier.

SUPPLEMENTAL COOLANT ADDITIVE (SCA)



CAUTION: Supplemental coolant additive contains alkali. Avoid contact with eyes. Avoid contact with skin. Do not take internally. In case of contact immediately wash skin with soap and water. For eyes, flush with large amounts of water for at least 15 minutes. Call a physician. **KEEP OUT OF REACH OF CHILDREN.** Follow all warnings on the container.

1. Important for heat exchanger cooled engines: Additional SCA's should NOT be added to the mixture of EGC/H₂O on initial fill up of engines with a coolant conditioner-filter. A high SCA concentration will result and can cause silicate-dropout. When this happens, a gel-type deposit is created in the cooling system which retards heat transfer and coolant flow.
2. If additional SCA's are needed, prepare a mixture of 50% quality water and 50%EGC (antifreeze). Add liquid SCA at a rate of 3%, by volume. Example: 30 mL of SCA per liter of H₂O/EGC mixture (1.0 fl oz of SCA per qt of H₂O/EGC). Add the resulting mixture to the cooling system in quart increments. Run the engine for 2 hours and retest the coolant. Continue process until SCA concentration meets recommended levels.
3. SCA is available from your Northern Lights dealer in the following sizes.
Pint - Part Number.....20-00002
1/2 gallon - Part Number.....20-00003
4. DO NOT use any coolant system additives containing soluble oil.

Servicing

COOLANT TESTING

1. Coolant test kits are available to allow on-site evaluation of the coolant condition.
2. The kits use small strips of paper which are dipped into the coolant. The paper changes color and indicates the SCA concentration. It also indicates the amount of EGC (antifreeze).
3. Test kits are available through your Northern Lights or Luggier Dealer.
4 Pack - Part Number.....20-00005
50 Pack - Part Number.....20-00010

SP-14. CHECKING COOLANT LEVEL



CAUTION: The cooling water in the engine reaches extremely high temperatures. You must use extreme caution when working on hot engines to avoid burns. Allow the engine to cool before working on the cooling system. Open the filler cap carefully, using protective clothing when the engine is warm.

1. Check the coolant level each day before starting the engine.
2. Remove the pressure cap from the expansion tank and check water level. In order to give the coolant an opportunity to expand, the level should be about 1 3/4 in. (4-5 cm) below the filler cap sealing surface when the engine is cold. When filling with coolant, the venting cock on top of the turbocharger (for engines fitted with turbocharger) should be opened to ensure that no air pockets form in the cooling system.
2. The pressure valve in the filler cap releases when the pressure is approximately 7 PSI (0.5 bar). Use a cap pressure tester to check cap if you suspect it is faulty.
4. The makeup coolant, added to compensate for loss or leaks, must meet engine coolant requirements outlined in previous section.

SP-15. FLUSHING THE COOLING SYSTEM



CAUTION: The cooling water in the engine reaches extremely high temperatures. You must use extreme caution when working on hot engines to avoid burns. Allow the engine to cool before working on the cooling system. Open the filler cap carefully, using protective clothing when the engine is warm.

1. Flush the cooling system and check for leaks and blockage every 2000 hours. The engine must be stopped and cold.
2. Close the seacock.
3. Remove the pressure cap from the expansion tank with caution. If applicable, open the cooling system air vent on top of turbocharger.
4. Open the drains on the exhaust manifold and engine block. Drain the fresh water system (see Component Locations, pages 4 - 6).
5. For vessels with keel cooling, the vessel must be out of the water to allow draining of the keel cooler.
6. With drains open, pour clean water into the expansion tank. When the water from drain is clear and free from discoloration and sediment, close that drain. When all drains are closed, flushing is complete.
7. Fill the fresh water system by pouring the recommended coolant mixture as described in previous sections.
8. Close cooling system air vent on turbocharger.
9. Open the seacock.
10. Start the engine. Check hoses and connections and repair any leakage.

SP-16. HEAT EXCHANGER CLEANING

1. Drain the cooling system.
2. Remove the cooling water pipes between the heat exchanger and the water pump inlet.
3. Disconnect hose to seawater pump.
4. Unscrew the attaching bolts holding the heat exchanger to the expansion tank.
5. Remove bolts holding heat exchanger cover.
6. Wash the core inside and out. If necessary, chemical agents can be used. Also clean the accessible parts of the heat exchanger housing.
7. Reassemble, using new gaskets and sealing rings.

Servicing

SP-17. ZINC ANODES

1. Zincs are installed in the cooling system to protect your engine from electrolysis. Check them faithfully every 250 hours. If you are in warm salt water or where electrolysis is a known problem, check them more often.

Heat exchanger cooled engine:

- a. Drain the raw water from heat exchanger (see Component Locations).
- b. Remove zinc holders from back of the tank and from front and port side of the heat exchanger (see Component Locations).

Keel Cooled engines.

- a. Drain expansion tank and remove zinc holder from tank (see Component Locations).
2. Scrape or steel brush the zinc electrode clean. If more than 50% of the electrode has eroded away, replace it with a new one. The electrode screws out of the holder.
 3. Reinstall the zinc holders. Be sure the threads are clean and have good metal to metal contact.

SP-18. RAW WATER PUMP

Heat exchanged cooled engines only.

1. Change the sea water pump impeller as needed.
2. Remove the pump end cover. Remove impeller with water pump pliers. Be sure you remove all pieces of a failed impeller.
3. Clean the inside of the housing.
4. Press in the new impeller and place the sealing washer in the outer end of the impeller center if this has not already been done.
5. Replace the cover using a new gasket.

Note: Make sure there is always an extra impeller and cover gasket in reserve and on-board.

DRIVEN EQUIPMENT

Gears and PTO's

1. Manufacturer's service recommendations vary. See your Owner's Manual for service information. If you do not have a manual, see your local dealer for the equipment in question.

NOTE: Some PTO and marine gears have rigid lubrication requirements. Follow service recommendations closely.

Generator Ends

2. The maintenance and operation recommendations for the generator end are in a separate Owner's Manual. If you do not have one of these manuals, contact your local Northern Lights dealer.

ELECTRICAL SYSTEM - GENERAL

1. Never switch battery switch off or break the circuit between the alternator and batteries while the engine is running. Regulator damage can result.
2. DO NOT reverse the polarity of battery cables when installing the battery.
3. When welding on the unit, disconnect the regulator and battery. Isolate the leads.
4. Disconnect battery cables when servicing the DC alternator.
5. Never test with a screwdriver, etc., against any terminal to see if it emits sparks.
6. A DC circuit breaker protects your control panel and wiring harness.

BOOSTER BATTERIES



CAUTION: Battery Gas Can Explode. Keep all flames and sparks away from batteries.

1. Before changing or using booster batteries, check battery electrolyte level. Add distilled water.
2. Booster and main batteries must have the same voltage rating.
3. First, connect positive (+) terminal of booster battery to positive (+) terminal of main battery.

Servicing

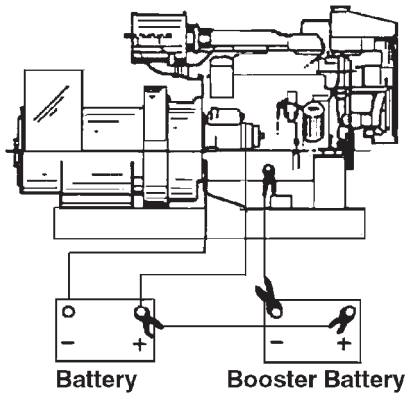

Figure 25: Booster Battery Connections

4. Then, connect negative (-) terminal of booster battery to ground on the engine block (see Figure 26).
5. Remove booster battery after starting engine.
6. Sealed batteries: see manufacturer charging and booster instructions.

BATTERY CARE - LEAD/ACID TYPE BATTERIES

SP-19. CHECK ELECTROLYTE LEVEL

1. Check electrolyte level every 50 hours or once per month. Add distilled water to manufacturer's recommended level.

SP-20. CHECK CABLES AND TERMINALS

2. Batteries, cables and cable terminals should be checked and cleaned every 100 hours. Clean corrosion with a water and baking soda solution. Flush with clean water. Tighten terminals and grease them to inhibit corrosion.
3. Check the battery condition with a hydrometer every 500 hours.

SP-21. CRANKCASE VENT SYSTEM

1. For sea water aftercooled units the crankcase vent system is a good option, and now standard equipment for M1064A, M1066A1, M1066A2, and M1066A3 units as of July 2008.

Check the red filter service indicator button daily - if it pops up the filter element needs to be changed. After changing the element, unscrew the clear plastic cover on the button and push the indicator down to reset it, then replace the cover.

Note: This service should be performed with the engine shut down. The vacuum in the filter canister because of engine operation may make it difficult to take apart.

Normally, the filter element should be changed every 250 hours.

SP-22. AFTERCOOLER

1. The aftercooler should be removed and inspected for deposits and the air side cleaned every 2000 hours.

WINTERIZING, OUT-OF-SERVICE

If the generator set will not be used for more than 3 months the following preparations should be taken for long term storage.

- Change engine oil and filter, using API CJ or CK-4, 15W-40 oil.
- Run the engine up to at least 140° F from a small, clean source of fuel dosed with either “Stab-il” brand fuel system stabilizer (diesel engine formula), or Stanadyne Performance fuel system conditioner. If neither of these fuel treatments is available, you may also use John Deere fuel system conditioner.
- Completely drain, flush, and fill the cooling system with pre-mixed, 50/50, conventional ethylene-glycol heavy-duty diesel engine coolant (with SCAs).
- Loosen alternator drive belt.
- Completely seal off intake and exhaust openings with heavy plastic bags and duct tape.
- Cover entire engine in large plastic bag and tape closed at bottom of bag-place several moisture absorbing desiccant packs inside plastic bag Store engine in original shipping crate, if possible, or other suitable storage crate.
- Store engine inside a building (preferably climate controlled) to prevent corrosion.

To Remove Generator Set from Long-Term Storage:

1. Take off all protective coverings and unseal all the openings that were covered up.
2. Install batteries that are fully charged and connect the terminals.
3. Install the fan and alternator belts if they had been removed.
4. Fill the fuel tank.
5. Perform all pre-start checks.
6. Crank the engine for 20 seconds with the starter, without letting the engine start. Wait 2 minutes and crank the engine an additional 20 seconds to make sure all bearing surfaces are well coated.
7. Start the engine and run at no load in a low idle for several minutes. Make sure the engine is warmed up and check gauges before going under load.
8. Check all gauges and check for leaks.

Troubleshooting

If you cannot correct problems with these procedures, see your **Lugger or Northern Lights** dealer.

ENGINE

✓ Engine Hard to Start or Will Not Start

Engine starting under load.

- Disengage PTO if applicable.

Improper starting procedure:

- See starting section of this manual. Take special note of Bypass Switch operation.

No fuel:

- Check level of fuel in fuel tank.

Low battery output:

- Check electrolyte level and condition.

Excessive resistance in starting circuit:

- Clean and tighten all battery connections.

Crankcase oil too heavy:

- Use oil of proper viscosity.

Improper type of fuel:

- Consult fuel supplier and use proper type of fuel for operating condition.

Water, dirt or air in fuel system:

- Drain, flush, fill and bleed system.

Clogged primary fuel filter element:

- Clean or replace filter element.

Clogged secondary fuel filter element:

- Replace filter element.

Dirty or faulty injection nozzles:

- Have your dealer check injection nozzles.

Electronic Fuel System problem (if equipped):

- See your dealer.

Injection pump not getting fuel or air in fuel system.

- Check fuel flow at supply pump or bleed fuel system.

✓ Engine Runs Irregularly or Stalls Frequently

Below normal engine temperature:

- Remove and check thermostat.

Clogged primary fuel filter element:

- Clean or replace filter element.

Clogged secondary fuel filter element:

- Replace secondary filter element.

Water or dirt in the fuel system:

- Drain, flush, fill and bleed system.

Dirty or faulty injection nozzles:

- Have your dealer check injection nozzles.

Air in fuel system:

- Inspect clamps and hoses on suction side of fuel pump for air leak, bleed fuel system.

Improper type of fuel:

- Consult fuel supplier and use proper type of fuel for operating condition.

✓ Lack of Engine Power

Intake air restriction:

- Service air cleaner.
- Service aftercooler.

Clogged primary fuel filter element:

- Clean or replace filter element.

Clogged secondary fuel filter element:

- Replace filter element.

Improper type of fuel:

- Consult fuel supplier and use proper type of fuel for operating conditions.

Overheated engine:

- See “Engine Overheats” in next category.

Below normal engine temperature:

- Remove and check thermostat.

Injection pump out of time.

- See your dealer.

Electronic fuel system problem.

- See your dealer.

Turbocharger not functioning (if equipped).

- See your dealer.

Leaking exhaust manifold gasket.

- See your dealer.

Defective aneroid control line.

- See your dealer.

Restricted fuel hose.

- Clean or replace fuel hose.

Low fast idle speed.

- See your dealer.

Improper valve clearance:

- Reset valves. Best done by dealer.

Dirty or faulty injection nozzles:

- Replace injectors. Best done by dealer.
- See your local dealer.

✓ Engine Knocks

Low oil level:

- Add oil to engine crankcase.

Injection pump out of time:

- Call your dealer.

Below normal engine temperature:

- Check your thermostats.
- Check water temperature to see if temperature gauge is working properly.

Engine overheating:

- See “Engine Overheating” section.

Troubleshooting

If you cannot correct problems with these procedures, see your **Lugger or Northern Lights** dealer.

✓ Engine Overheats

Engine overloaded.

- Reduce the load.

Low coolant level:

- Fill tank or radiator to proper level.
- Check hoses for loose connections and leaks.

Keel cooling tubes have been painted (marine):

- Remove paint from tubes.

Stretched belt or defective belt tensioner.

- Check automatic belt tensioner and check belts for stretching. Replace as required.

Low engine oil level.

- Check oil level, add oil as needed.

Incorrect grade of fuel.

- Use correct grade of fuel.

Cooling system needs flushing:

- Flush cooling system.

Defective thermostat:

- Remove and check thermostat.

Defective temperature gauge:

- Check water temperature with thermometer and replace gauge if necessary.

Water pump impeller worn/broken:

- Check impeller and replace if necessary.

✓ High Fuel Consumption

Engine overloaded.

- Reduce load.

Air in fuel system:

- Bleed fuel system.

Improper type of fuel:

- Use correct fuel for temperature.

Clogged or dirty air cleaner:

- Service air cleaner.

Improper valve clearance:

- See your dealer.

Injection nozzles dirty:

- See your dealer.

Injection pump out of time:

- See your dealer.

Electronic fuel system problem.

- See your dealer.

Engine not at proper temperature:

- Check your thermostats.
- Check water temperature with thermometer and replace gauge if necessary.

✓ Below Normal Engine Temperature

Thermostats not working properly:

- Check thermostats.

Temperature gauge not working properly:

- Check water temperature with thermometer.

✓ Low Oil Pressure

Low oil level:

- Fill crankcase to proper level.

Improper type of oil:

- Drain and fill crankcase with correct oil.

Partially plugged oil filter:

- Replace filter.

✓ High Oil Consumption

Break-in period:

- Oil consumption decreases after break in.

Crankcase oil too light:

- Use proper viscosity oil.

Oil leaks:

- Check for leaks in lines around gaskets and drain plug.

✓ Engine Emits Black or Gray Exhaust Smoke

Clogged or dirty air cleaner:

- Service air cleaner.

Clogged aftercooler:

- Service aftercooler.

Defective muffler (back pressure too high):

- Have dealer check back pressure.

Improper fuel:

- Use correct fuel for temperature.

Engine overloaded.

- Reduce load.

Electronic fuel system problem.

- See your dealer.

Turbocharger not functioning.

- See your dealer.

Injection nozzles dirty:

- See your dealer.

Engine out of time:

- See your dealer.

✓ Engine Emits White Smoke

Improper fuel:

- Use correct fuel for temperature.

Cold engine:

- Warm up engine to normal operating temperature.

Defective thermostat:

- Remove and check thermostat.

Engine out of time:

- See your dealer.

Defective injection nozzles.

- See your dealer.

Troubleshooting

If you cannot correct problems with these procedures, see your **Lugger or Northern Lights** dealer.

DC ELECTRICAL SYSTEM

✓ Battery Will Not Charge

Loose or corroded connections:

- Clean and tighten battery connections.

Sulfated or worn out batteries:

- Check specific gravity of each battery cell.
- Check electrolyte level of each battery cell.

Loose or defective alternator belt:

- Adjust belt tension.
- Replace belt.

✓ Undercharged Electrical System

Excessive electrical load from added accessories:

- Take off accessories or install higher output alternator.

Engine idling excessively.

- Increase the engine RPM when there is a heavy electrical load.

Poor electrical connections on battery, ground strap, starter, or alternator.

- Inspect connections and clean if necessary.

Defective battery.

- Test battery.

Battery charging rate too high.

- Test charging system.

✓ Starter Inoperative

PTO engaged.

- Disengage PTO.

Check DC circuit breaker:

- If the breaker is tripped, reset it.

Faulty start circuit relay.

- See dealer.

Blown main system fuse.

- Replace fuse.

Loose or corroded connections:

- Clean and tighten loose battery and harness plug connection.

Low battery output:

- Check specific gravity of each battery cell.
- Check electrolyte level of each battery cell.

Defective electrical system ground wire:

- Repair or replace.

✓ Starter Cranks Slowly

Low battery output:

- Battery is too small.
- Battery cables are too small.

Check specific gravity of each battery cell:

- Replace battery if necessary.

Check electrolyte level of each battery cell:

- If low, fill cells with distilled water.

Crankcase oil too heavy:

- Fill with oil of appropriate viscosity.

Loose or corroded connections:

- Clean and tighten loose connections.

✓ Starter and Hour Meter Function but rest of Electrical System Does Not Function

Blown fuse on magnetic switch.

- Replace fuse.

✓ Entire Electrical System Does Not Function

Check DC circuit breaker:

- If breaker is tripped, reset it.

Faulty connection:

- Clean and tighten battery and harness plug connections.

Sulfated or worn out batteries:

- Check specific gravity and electrolyte level of each battery cell.

AC Wiring Diagram

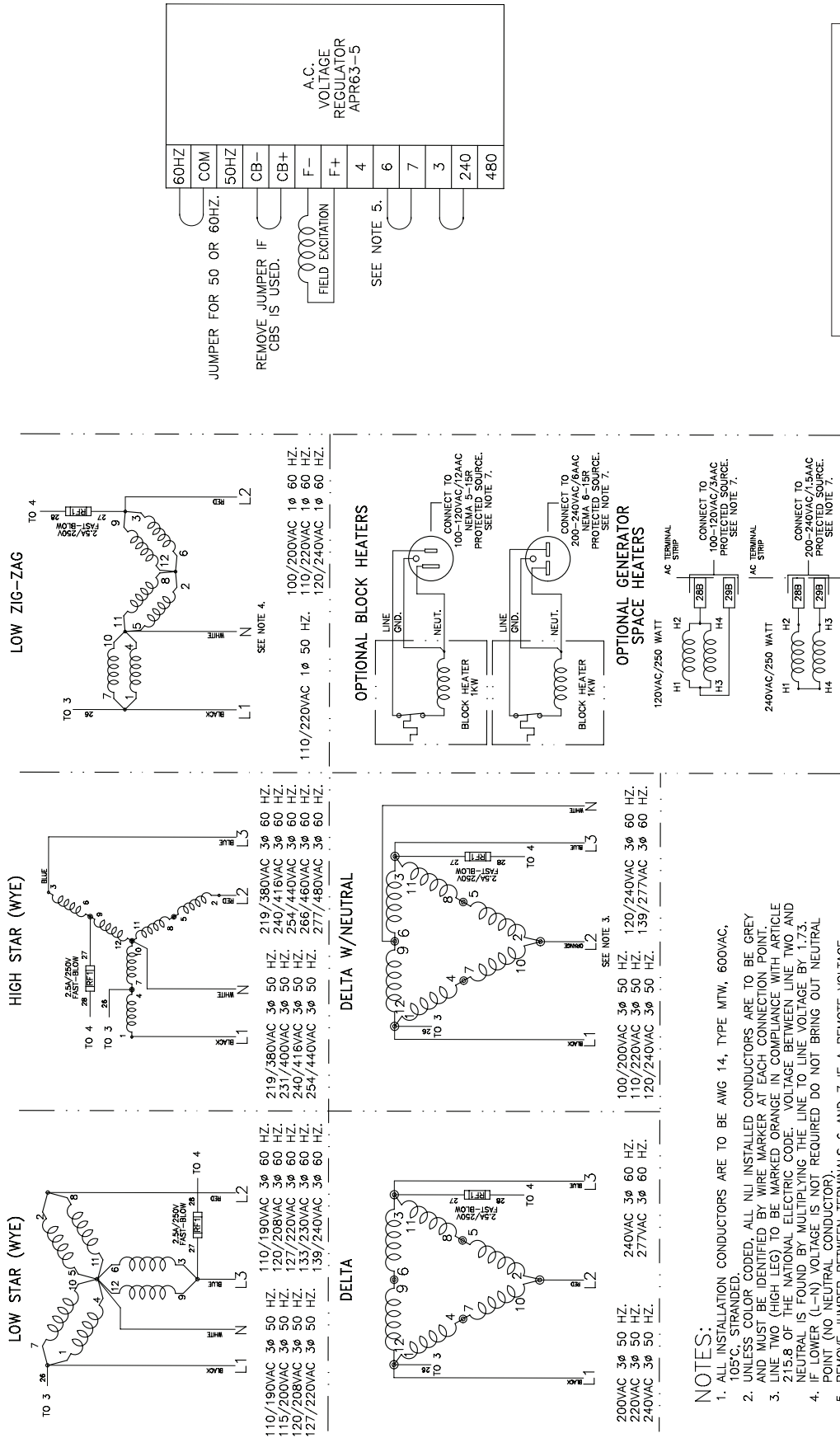

PROPRIETARY AND CONFIDENTIAL

A.C. Wiring - All voltages
with an APR63-5 (Non-PMG)
Drawing B-5689F

NOTES:

1. ALL INSTALLATION CONDUCTORS ARE TO BE AWG 14, TYPE MTW, 600VAC, 105C, STRANDED.
2. UNLESS COLORS CODED, ALL WIRE INSTALLED CONDUCTORS ARE TO BE GREY AND MUST BE IDENTIFIED BY WIRE MARKER AT EACH CONNECTION POINT.
3. LINE (HIGH LEG) TO BE MARKED ORANGE IN COMPLIANCE WITH ARTICLE 215.8 OF THE NATIONAL ELECTRIC CODE.
4. NEUTRAL IS FOUND BY MULTIPLYING THE LINE TO LINE VOLTAGE BY 1.732. IF POWER (LINE) VOLTAGE IS NOT REQUIRED DO NOT BRING OUT NEUTRAL POINT (NEUTRAL CONDUCTOR).
5. REMOVE JUMPER BETWEEN TERMINALS 6 AND 7 IF A REMOTE VOLTAGE ADJUST RHEOSTAT IS USED.
6. GENSETS ARE TO BE GROUNDED BY CUSTOMER, AT CUSTOMER'S DISCRETION.
7. DO NOT ENERGIZE HEATERS WHILE GENSET IS IN OPERATION.

A.C. Wiring Diagram

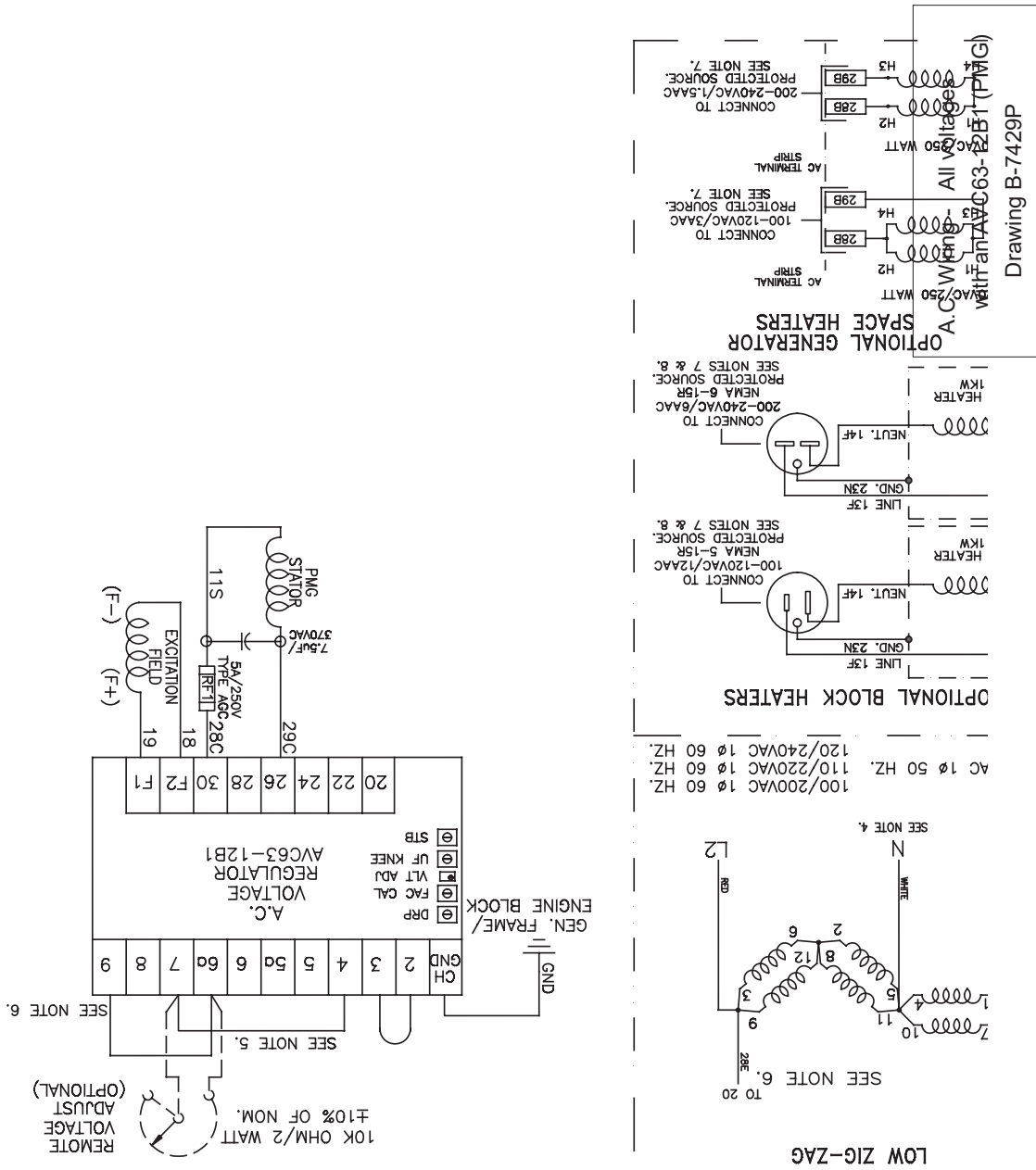

Drawing B-7429P

A.C. Wiring Diagram

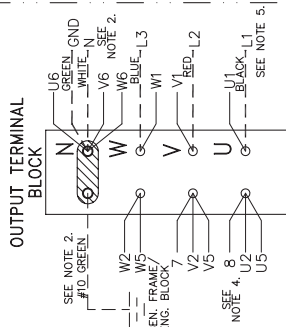
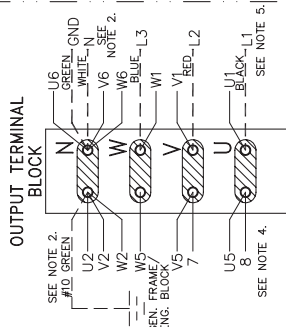
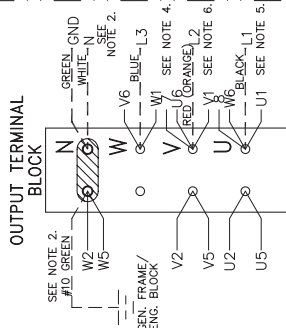
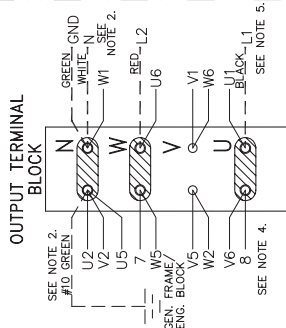
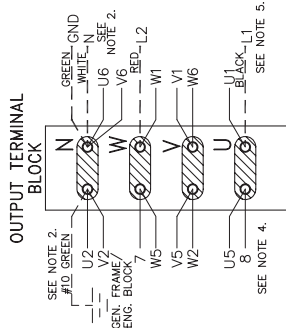

12 WIRE HIGH WYE 3Ø
220/380VAC - 254/440VAC 50 HZ
240/416VAC - 277/480VAC 60 HZ

12 WIRE LOW WYE 3Ø
110/190VAC - 127/220VAC 50 HZ
120/208VAC - 139/240VAC 60 HZ

12 WIRE SERIES DELTA 3Ø
110/220VAC 50 HZ
120/240VAC 60 HZ
L2 IS HIGH LEG

12 WIRE DOUBLE DELTA 1Ø
110/220VAC 50 HZ
120/240VAC 60 HZ

12 WIRE ZIG ZAG 1Ø
110/220VAC 50 HZ
120/240VAC 60 HZ

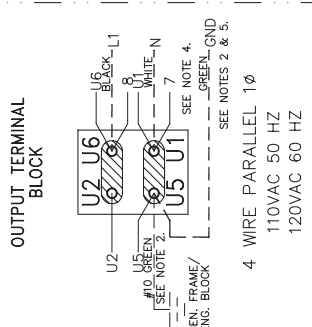
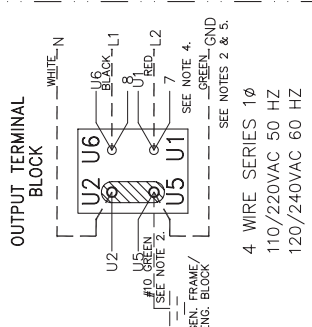
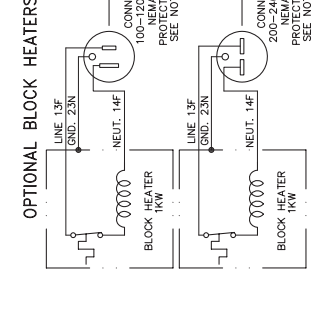
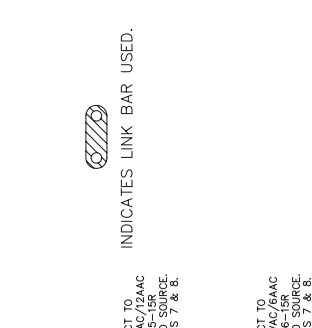
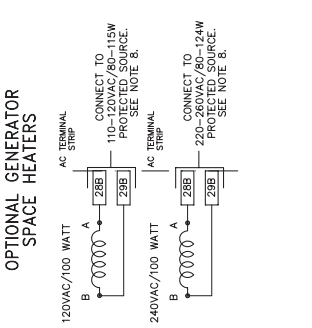

4 WIRE PARALLEL 1Ø
110VAC 50 HZ
120VAC 60 HZ

4 WIRE SERIES 1Ø
110/220VAC 50 HZ
120/240VAC 60 HZ

4 WIRE SERIES 50 HZ
110/220VAC 50 HZ
120/240VAC 60 HZ

4 WIRE SERIES 60 HZ
110/220VAC 50 HZ
120/240VAC 60 HZ

4 WIRE PARALLEL 1Ø
110VAC 50 HZ
120VAC 60 HZ

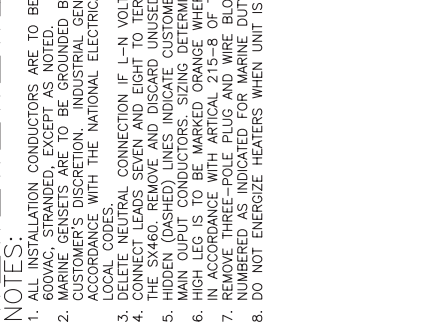
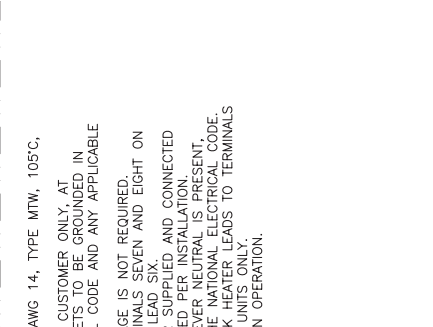
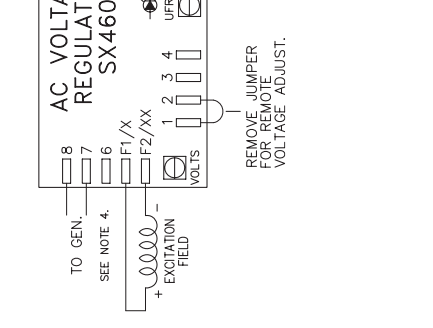
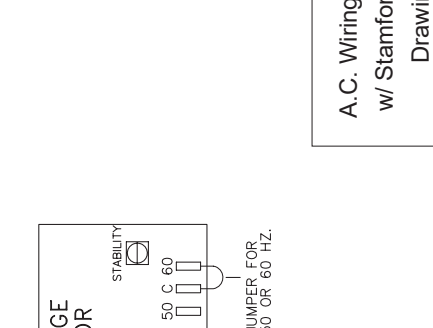
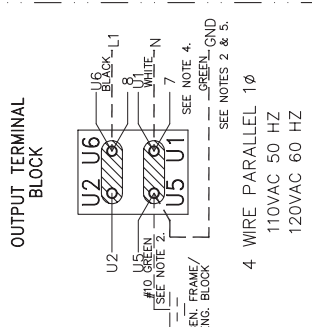
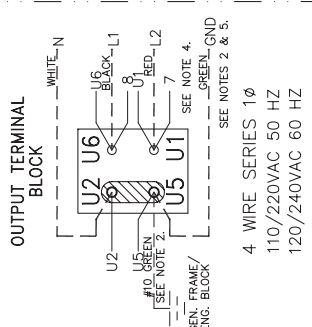
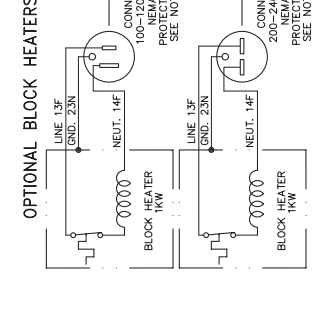
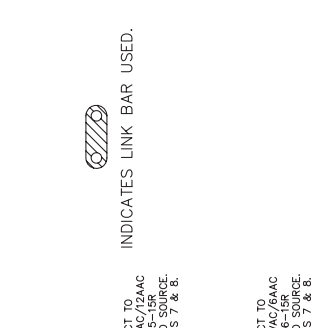
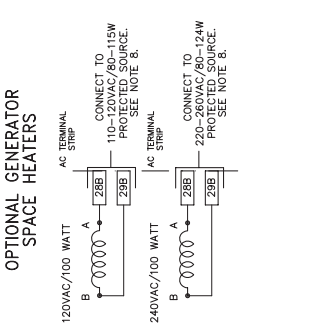

AC VOLTAGE REGULATOR SX460
TO GEN. SEE NOTE 4.
EXCITATION FIELD
VOLTS 1 2 3 4
STABILITY
JUMPER FOR 50 OR 60 HZ.
REMOVE JUMPER FOR REMOTE VOLTAGE ADJUST.

AC VOLTAGE REGULATOR SX460
TO GEN. SEE NOTE 4.
EXCITATION FIELD
VOLTS 1 2 3 4
STABILITY
JUMPER FOR 50 OR 60 HZ.
REMOVE JUMPER FOR REMOTE VOLTAGE ADJUST.

AC VOLTAGE REGULATOR SX460
TO GEN. SEE NOTE 4.
EXCITATION FIELD
VOLTS 1 2 3 4
STABILITY
JUMPER FOR 50 OR 60 HZ.
REMOVE JUMPER FOR REMOTE VOLTAGE ADJUST.

AC VOLTAGE REGULATOR SX460
TO GEN. SEE NOTE 4.
EXCITATION FIELD
VOLTS 1 2 3 4
STABILITY
JUMPER FOR 50 OR 60 HZ.
REMOVE JUMPER FOR REMOTE VOLTAGE ADJUST.

AC VOLTAGE REGULATOR SX460
TO GEN. SEE NOTE 4.
EXCITATION FIELD
VOLTS 1 2 3 4
STABILITY
JUMPER FOR 50 OR 60 HZ.
REMOVE JUMPER FOR REMOTE VOLTAGE ADJUST.

- NOTES:**
1. ALL INSTALLATION CONDUCTORS ARE TO BE AWG 14, TYPE MTW, 105°C, 600VAC, STRANDED, EXCEPT AS NOTED.
 2. MARINE GENSSETS ARE TO BE GROUNDED BY CUSTOMER ONLY. AT CUSTOMER'S DISCRETION, INDUSTRIAL GENSSETS TO BE GROUNDED IN ACCORDANCE WITH THE NATIONAL ELECTRICAL CODE AND ANY APPLICABLE LOCAL CODES.
 3. DELETE NEUTRAL CONNECTION IF L-N VOLTAGE IS NOT REQUIRED.
 4. CONNECT LEADS SEVEN AND EIGHT TO TERMINALS SEVEN AND EIGHT ON THE SX460. REMOVE AND DISCARD UNUSED LEAD SIX.
 5. HIDDEN (DASHED) LINES INDICATE CUSTOMER SUPPLIED AND CONNECTED MAIN OUTPUT CONDUCTORS. SIZING DETERMINED PER INSTALLATION.
 6. HIGH LEG IS TO BE MARKED ORANGE WHEREVER NEUTRAL IS PRESENT.
 7. REMOVE THREE-POLE PLUS ANCHOR WIRE BLOCK HEATER LEADS TO TERMINALS NUMBERED AS INDICATED FOR MARINE DUTY UNITS ONLY.
 8. DO NOT ENERGIZE HEATERS WHEN UNIT IS IN OPERATION.

A.C. Wiring - AVR SX460
w/ Stamford 4 & 12 wire
Drawing B-5073M

D.C. Wiring Diagram

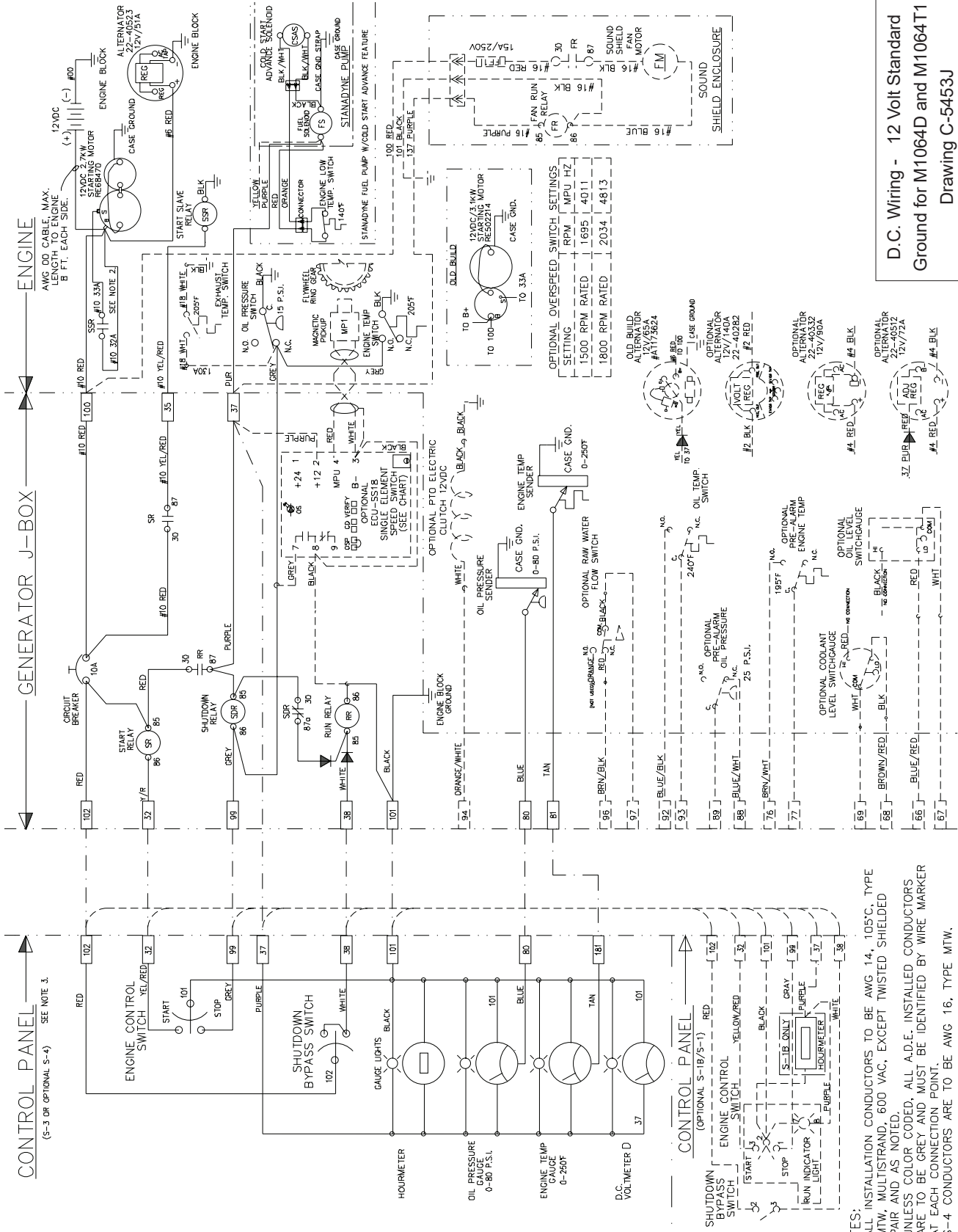

D.C. Wiring - 12 Volt Standard
Ground for M1064D and M1064T1
Drawing C-5453J

CONTROL PANEL
(5-3 OR OPTIONAL 5-4) SEE NOTE 3.

GENERATOR J-BOX

ENGINE

12VDC CABLE, MAX. LENGTH TO ENGINE 8 FT. EACH SIDE.

OPTIONAL OVERSPEED MOTOR
RES05214
12VDC/3.1KW
TO 100- TO 33A
CASE GND.

OPTIONAL OVERSPEED SETTINGS

SETTING	RPM	MPU	HZ
1500 RPM RATED	1695	4011	
1800 RPM RATED	2034	4813	

OPTIONAL ALTERNATOR #1173624
12V/65A
CASE GND.

OPTIONAL ALTERNATOR #2-40332
12V/80A
CASE GND.

OPTIONAL ALTERNATOR #2-40282
12V/72A
CASE GND.

OPTIONAL ALTERNATOR #2-40332
12V/80A
CASE GND.

OPTIONAL ALTERNATOR #2-40282
12V/72A
CASE GND.

- NOTES:
1. ALL INSTALLATION CONDUCTORS TO BE AWG 14, 105°C, TYPE MTW, MULTISTRAND, 600 VAC, EXCEPT TWISTED SHIELDED PAIR AND AS NOTED.
 2. UNLESS COLOR CODED, ALL A.D.E. INSTALLED CONDUCTORS ARE TO BE GREY AND MUST BE IDENTIFIED BY WIRE MARKER AT EACH CONNECTION POINT.
 3. S-4 CONDUCTORS ARE TO BE AWG 16, TYPE MTW.

D.C. Wiring Diagram

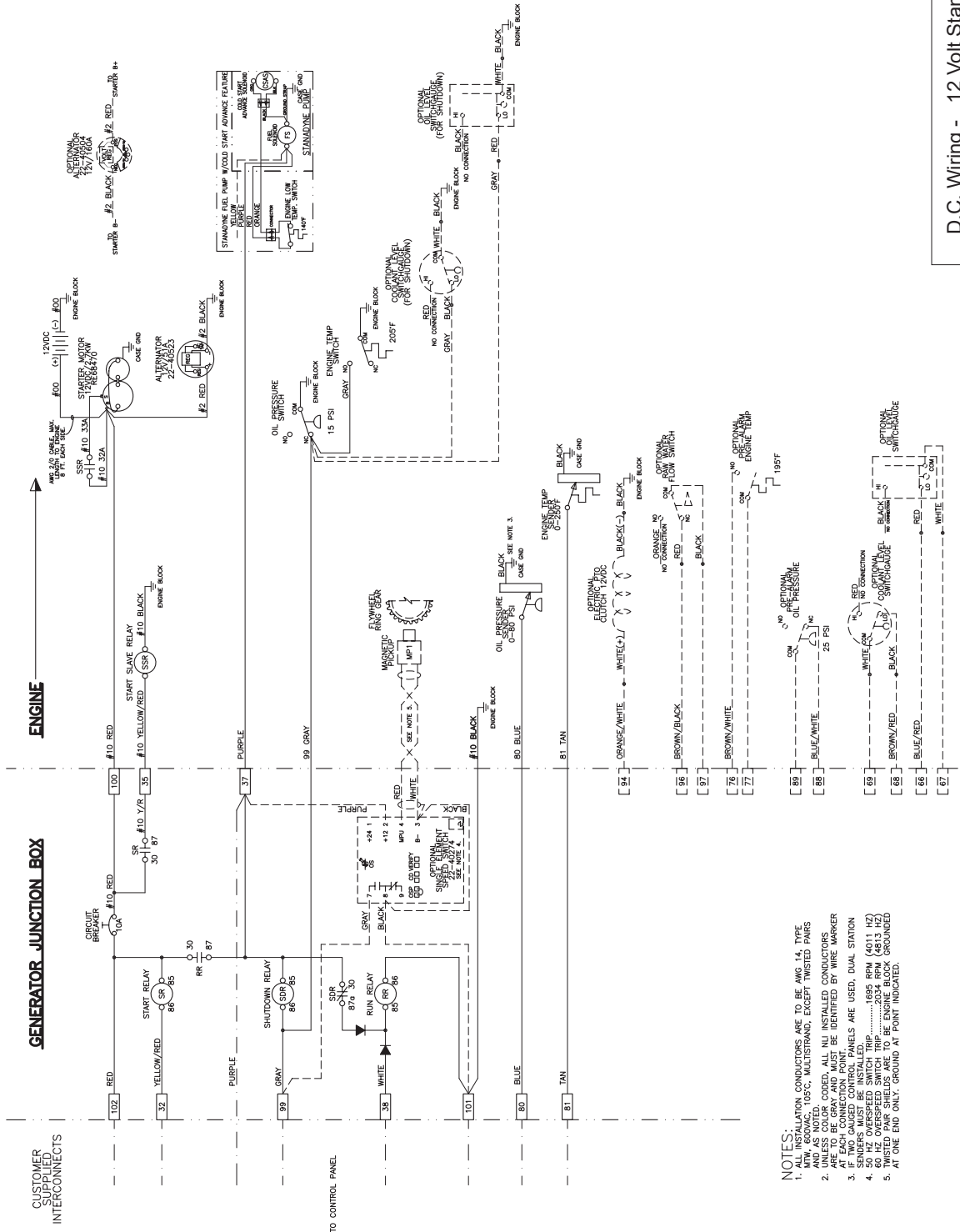

- NOTES:**
1. WIRE TERMINATION CONDUITS ARE TO BE NMC 1/4" TYPE WITH INSULATED WIRE, MULTISTRAND, EXCEPT WIRELESS PARES AND AS NOTED.
 2. ALL WIRE TO BE COLORED AND LABELLED CONDUCTORS ARE TO BE GREEN AND MUST BE IDENTIFIED BY WIRE MARKER AT EACH CONNECTION POINT.
 3. SENSORS MUST BE INSTALLED IN ACCORDANCE WITH MANUFACTURER'S INSTRUCTIONS.
 4. 50 HZ OVERSPEED SWITCH TRIP POINT: 1895 RPM (4011 HZ)
 5. WASTED PAIR SHIELDS ARE TO BE ENGINE BLOCK GROUNDING AT ONE END ONLY. GROUND AT POINT INDICATED.

D.C. Wiring - 12 Volt Standard
Ground for M40C2 and M55C2
Drawing C-6916

D.C. Wiring Diagram

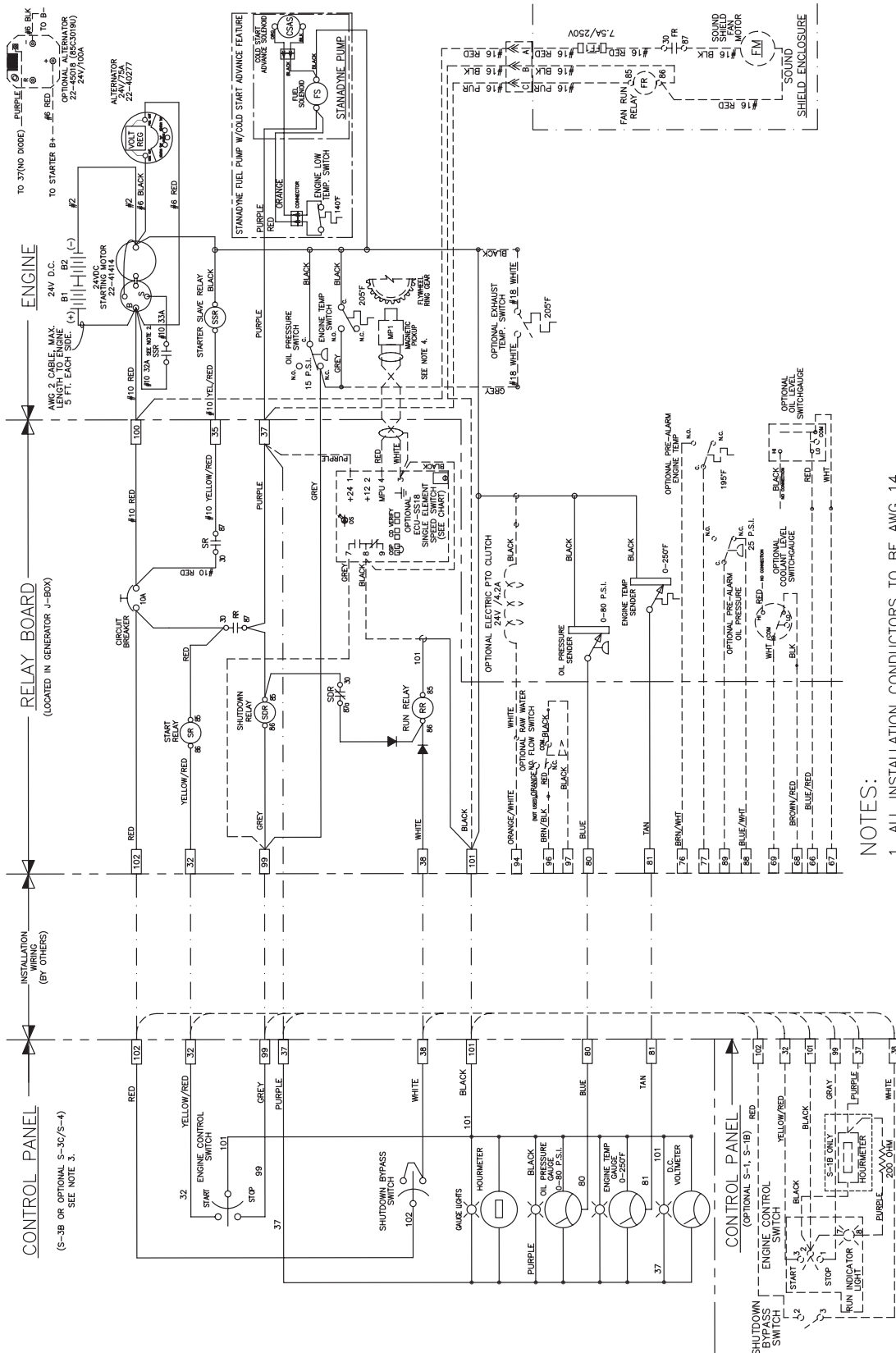

D.C. Wiring - 24 Volt Isolated
Ground for M1064D and M1064T1
Drawing C-5759D

- NOTES:**
1. ALL INSTALLATION CONDUCTORS TO BE AWG 14, 105°C, TYPE MTW, 600VAC, MULTISTRAND.
 2. UNLESS COLOR CODED, ALL A.D.E. INSTALLED CONDUCTORS ARE TO BE GREY AND MUST BE IDENTIFIED BY WIRE MARKER AT EACH CONNECTION POINT.
 3. ALL S-4 CONTROL PANEL CONDUCTORS TO BE AWG 16, 105°C, TYPE MTW, 600VAC, MULTISTRAND.
 4. TWISTED PAIR SHIELD IS TO BE GROUNDED AT ONE END ONLY. GROUND AT POINT INDICATED.

SPEED SWITCH SETTINGS (142T)

SETTING	R.P.M.	FREQUENCY
CRANK DISCONNECT	500	1183 HZ.
OVERSPEED	1695	4011 HZ.
OVERSPEED	2034	4813 HZ.

D.C. Wiring Diagram

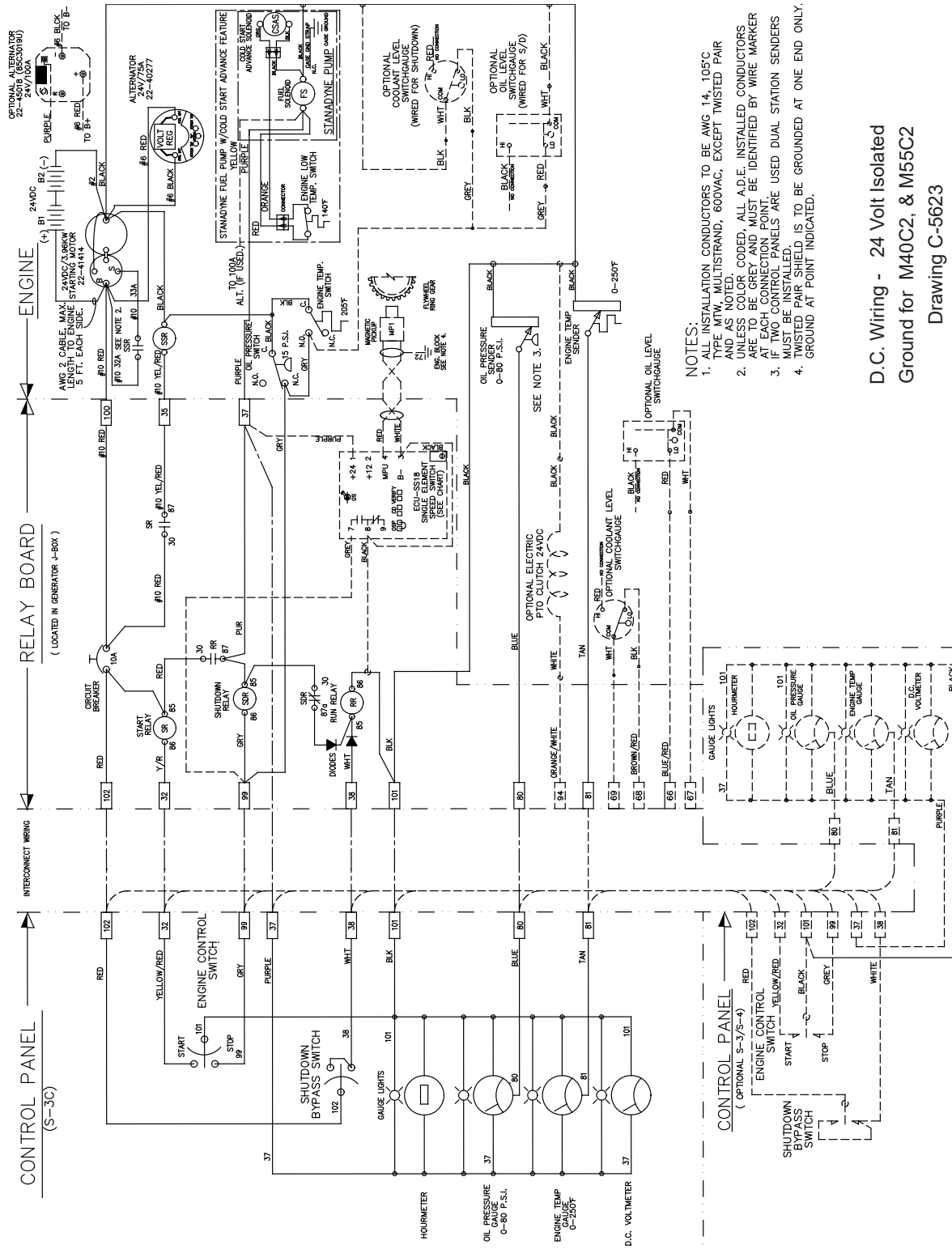

- NOTES:**
1. ALL INSTALLATION CONDUCTORS TO BE AWG 14, 105°C TYPE MTW, MULTISTRAND, 600VAC, EXCEPT TWISTED PAIR AND AS NOTED.
 2. UNLESS COLOR CODED, ALL A.D.E. INSTALLED CONDUCTORS ARE TO BE GREY AND MUST BE IDENTIFIED BY WIRE MARKER AT EACH CONNECTION POINT.
 3. IF TWO CONTROL PANELS ARE USED DUAL STATION SENDERS MUST BE USED. THE SENDERS ARE TO BE IDENTIFIED BY TWISTED PAIR SHIELD. IS. TO BE GROUNDING AT ONE END ONLY.
 4. GROUND AT POINT INDICATED.

D.C. Wiring - 24 Volt Isolated
 Ground for M40C2, & M55C2
 Drawing C-5623

D.C. Wiring Diagram

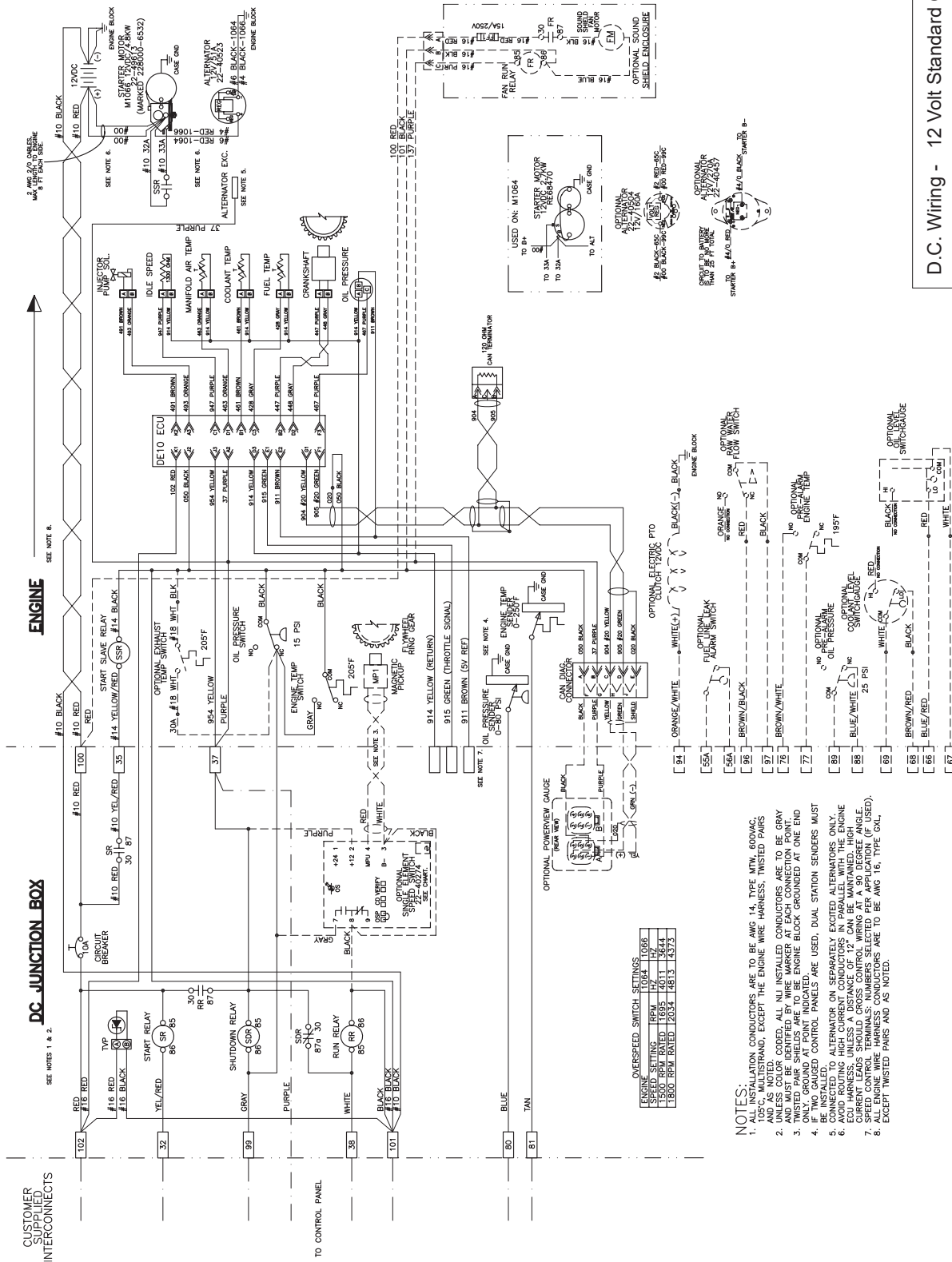

OVERSPEED SWITCH SETTINGS

SPEED SETTING	RPM	HZ
1500 RPM	100	16.7
1600 RPM	107	17.7
1700 RPM	114	18.8
1800 RPM	121	20.0
1900 RPM	129	21.2
2000 RPM	136	22.4
2100 RPM	144	23.6
2200 RPM	151	24.8
2300 RPM	159	26.0
2400 RPM	166	27.2
2500 RPM	174	28.4
2600 RPM	181	29.6
2700 RPM	189	30.8
2800 RPM	196	32.0
2900 RPM	204	33.2
3000 RPM	211	34.4
3100 RPM	219	35.6
3200 RPM	226	36.8
3300 RPM	234	38.0
3400 RPM	241	39.2
3500 RPM	249	40.4
3600 RPM	256	41.6
3700 RPM	264	42.8
3800 RPM	271	44.0
3900 RPM	279	45.2
4000 RPM	286	46.4
4100 RPM	294	47.6
4200 RPM	301	48.8
4300 RPM	309	50.0
4400 RPM	316	51.2
4500 RPM	324	52.4
4600 RPM	331	53.6
4700 RPM	339	54.8
4800 RPM	346	56.0
4900 RPM	354	57.2
5000 RPM	361	58.4
5100 RPM	369	59.6
5200 RPM	376	60.8
5300 RPM	384	62.0
5400 RPM	391	63.2
5500 RPM	399	64.4
5600 RPM	406	65.6
5700 RPM	414	66.8
5800 RPM	421	68.0
5900 RPM	429	69.2
6000 RPM	436	70.4
6100 RPM	444	71.6
6200 RPM	451	72.8
6300 RPM	459	74.0
6400 RPM	466	75.2
6500 RPM	474	76.4
6600 RPM	481	77.6
6700 RPM	489	78.8
6800 RPM	496	80.0
6900 RPM	504	81.2
7000 RPM	511	82.4
7100 RPM	519	83.6
7200 RPM	526	84.8
7300 RPM	534	86.0
7400 RPM	541	87.2
7500 RPM	549	88.4
7600 RPM	556	89.6
7700 RPM	564	90.8
7800 RPM	571	92.0
7900 RPM	579	93.2
8000 RPM	586	94.4
8100 RPM	594	95.6
8200 RPM	601	96.8
8300 RPM	609	98.0
8400 RPM	616	99.2
8500 RPM	624	100.4
8600 RPM	631	101.6
8700 RPM	639	102.8
8800 RPM	646	104.0
8900 RPM	654	105.2
9000 RPM	661	106.4
9100 RPM	669	107.6
9200 RPM	676	108.8
9300 RPM	684	110.0
9400 RPM	691	111.2
9500 RPM	699	112.4
9600 RPM	706	113.6
9700 RPM	714	114.8
9800 RPM	721	116.0
9900 RPM	729	117.2
10000 RPM	736	118.4

- NOTES:**
1. ALL INSTALLATION CONDUCTORS ARE TO BE AWG 14, TYPE MTW, 600VAC, UNLESS OTHERWISE SPECIFIED. EXCEPT THE ENGINE WIRE HARNESS, TWISTED PAIRS AND AS NOTED.
 2. UNLESS COLOR CODED, ALL WIRE HARNESS CONDUCTORS ARE TO BE GRAY AND AS NOTED.
 3. TWISTED PAIR SHIELDS ARE TO BE ENGINE BLOCK GROUNDED AT ONE END ONLY. GROUND AT POINT INDICATED.
 4. IF INSULATED CONTROL PANELS ARE USED, DUAL STATION SENDERS MUST BE CONNECTED TO ALTERNATOR ON SEPARATELY EXCITED ALTERNATORS ONLY.
 5. AVOID ROUTING HIGH CURRENT CONDUCTORS IN PARALLEL WITH THE ENGINE WIRE HARNESS. IF PARALLEL ROUTING IS NECESSARY, MAINTAIN A MINIMUM 180 DEGREE ANGLE. CURRENT LEADS SHOULD CROSS CONTROL WIRING AT A 90 DEGREE ANGLE.
 6. SPEED CONTROL TERMINALS: NUMBERS SELECTED PER APPLICATION (IF USED).
 7. SPEED CONTROL TERMINALS: NUMBERS ARE TO BE AWG 16, TYPE GAL, EXCEPT TWISTED PAIRS AND AS NOTED.

D.C. Wiring - 12 Volt Standard Ground for M1064T2, M1064A, M1066T, and M1066A1
Drawing C-6890

D.C. Wiring Diagram

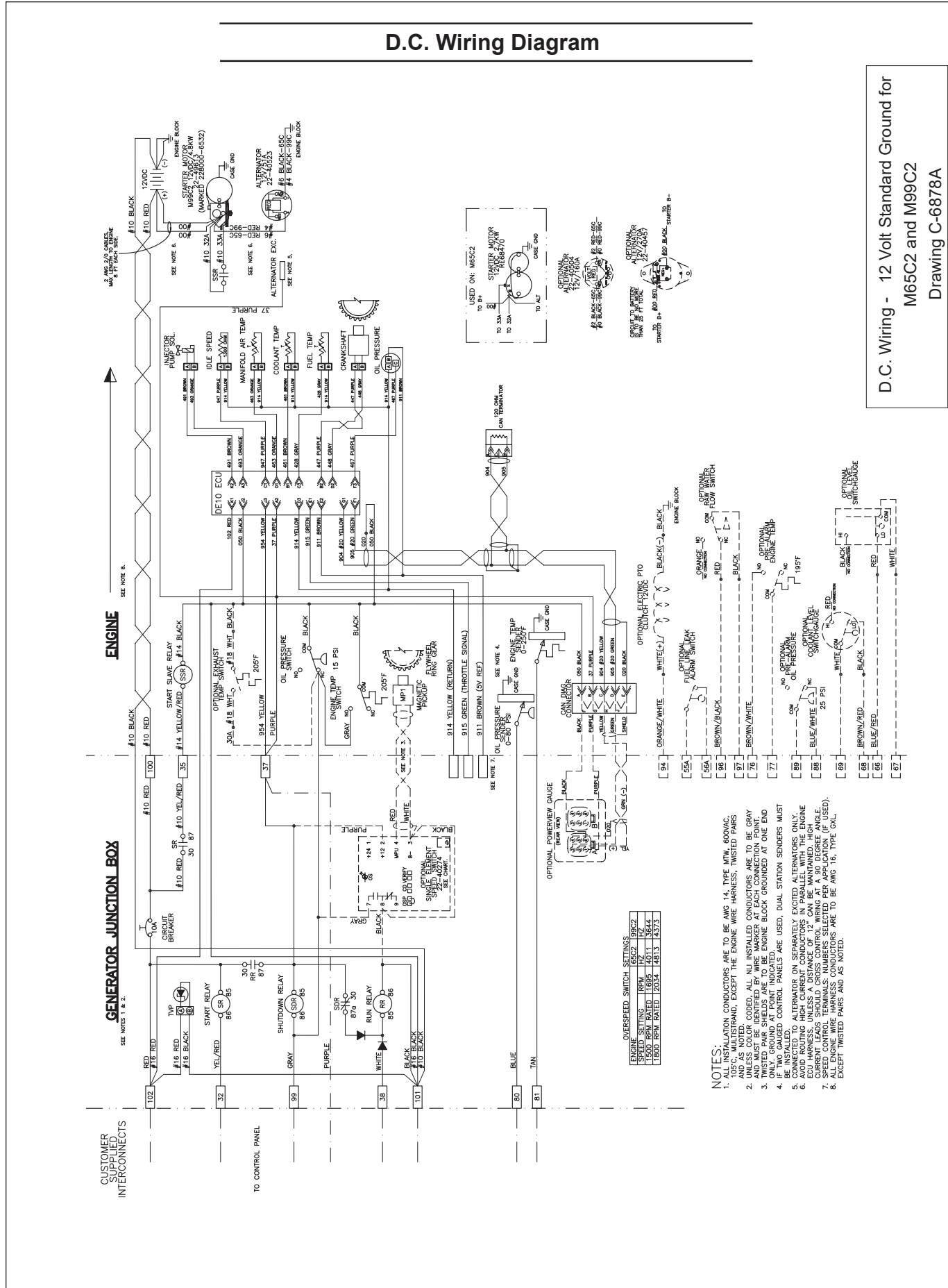

D.C. Wiring - 12 Volt Standard Ground for M65C2 and M99C2 Drawing C-6878A

D.C. Wiring Diagram

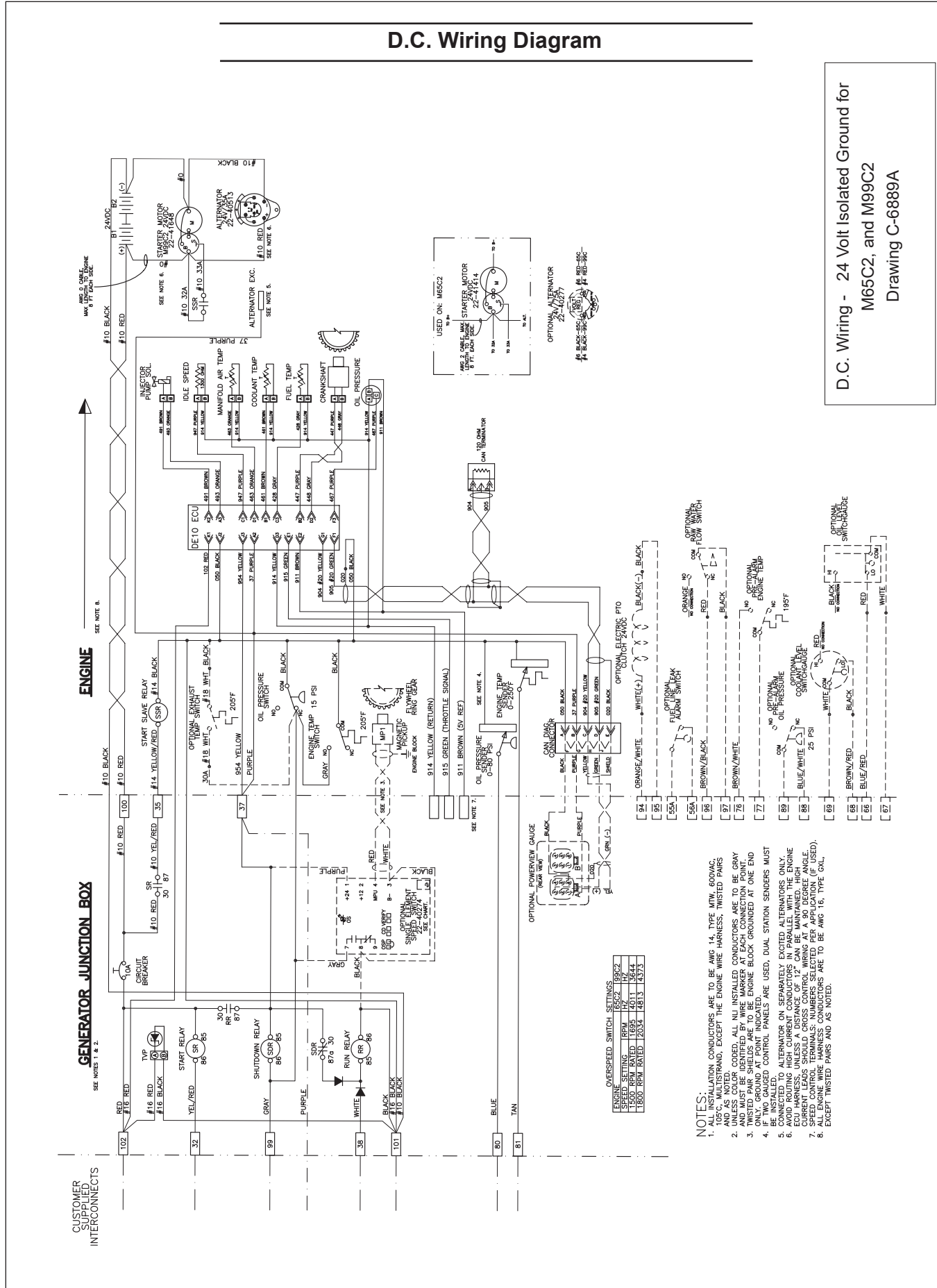

D.C. Wiring - 24 Volt Isolated Ground for M65C2, and M99C2 Drawing C-6889A

Notes

Panel Wiring Diagram

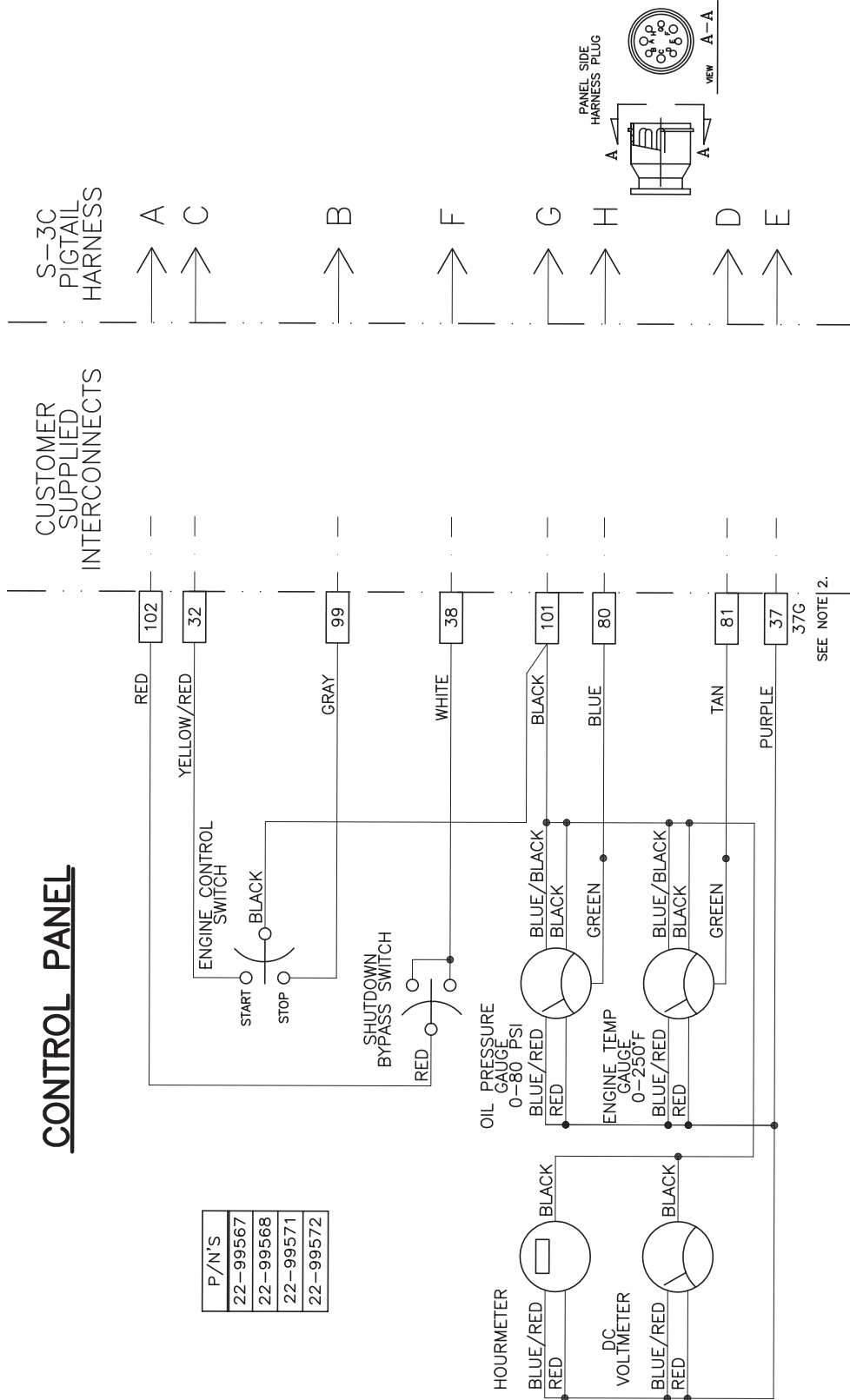

CONTROL PANEL

P/N'S
22-99567
22-99568
22-99571
22-99572

SEE NOTE 2.

NOTES:

1. ALL INSTALLATION CONDUCTORS ARE TO BE AWG 14, TYPE MTW, 600VAC, 105°C, STRANDED, EXCEPT AS NOTED.
2. RELABEL TERMINAL 37 TO 37G WHEN LIGHTING FUSE IS USED.
3. REFER TO DC WIRING DIAGRAM.
3. PIGTAIL HARNESS SUPPLIED WITH S-3C PANELS 22-99571 AND 22-99572 IS TO BE CONNECTED AT THE PANEL TERMINAL STRIP.

S-3B, S-3C Panel Wiring Diagram
1224 volt, Viewline
Drawing A-12638A

Panel Wiring Diagram

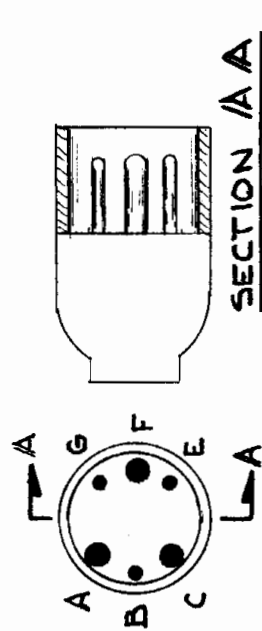
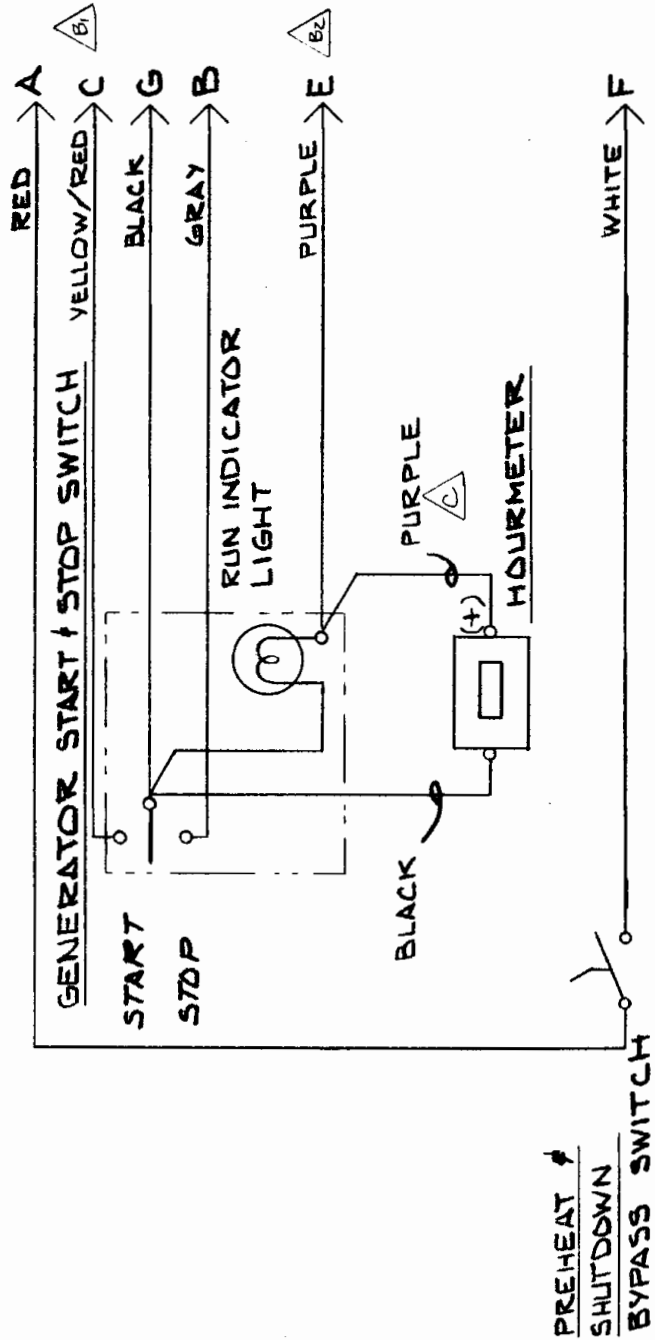

MOLEDED 6 PIN PLUG (BLACK)

S-1B Panel Wiring Diagram
12 volt
Drawing A-3170

On Board Spare Parts

Safety at sea depends on careful preparation, product knowledge, and having the right tools and parts. Below is a list of parts Northern Lights, Inc. recommends you carry onboard at all times.

Onboard Parts Kits are available from your dealer.

We consider these minimum quantities. Your vessel's operating conditions may require more of a given part. Consult your dealer. The example below lists typical items for either heat exchanged or keel cooled engines.

Item	Description	Quantity
1	Lube Oil Filter	4
2	Air Filter Element	1
3	Fuel Filter	2
4	Fuel Filter Element	4
5	Fuel Lift Pump	1
6	Injector	1
7	Thermostat	2
8	Thermostat Seal Ring	2
9	Thermostat Cover Gasket	1
10	Rocker Cover Gasket	2
11	Engine Overhaul Gasket Kit	1
12	Zinc Anode*	6
13	Raw Water Pump Impeller*	2
14	Raw Water Pump Cover Gasket*	2
15	Raw Water Pump*	1
16	Raw Water Pump Bearing*	2
17	Coolant Pump Repair Kit	1
18	Coolant Pump Gasket	1
19	Drive Belt	1
20	Workshop Manual	1

*Heat exchanger cooled engines only



4420 14th Ave. NW., Seattle WA 98107

Tel: (206) 789-3880 • 1-800-762-0165 • www.northern-lights.com

Northern Lights and Lugger are registered trademarks of Northern Lights, Inc.

© 2017 All rights reserved. Litho USA.