

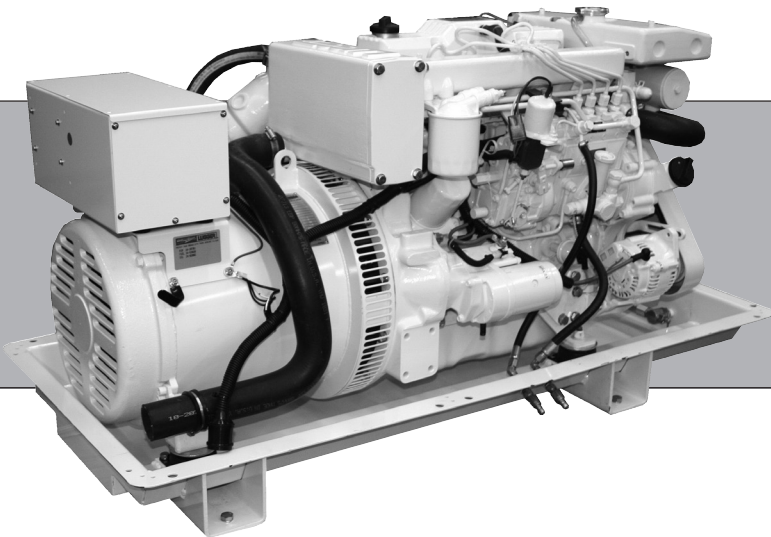

# OPERATOR'S MANUAL

## OM864W3

For Models: M864W and M864W3



[www.northern-lights.com](http://www.northern-lights.com)



— CALIFORNIA —  
Proposition 65 Warning:

**Breathing Diesel engine exhaust and some of its constituents are known to the State of California to cause cancer, birth defects, and other reproductive harm.**

- \* Always start and operate the engine in a well-ventilated area.
- \* If in an enclosed area, vent the exhaust to the outside.
- \* Do not modify or tamper with the exhaust system.
- \* Do not idle the engine except as necessary.

**For more information, go to [www.P65warnings.ca.gov/diesel](http://www.P65warnings.ca.gov/diesel).**

**Northern Lights**

4420 14th Avenue NW  
Seattle, WA 98107  
Tel: (206) 789-3880  
Fax: (206) 782-5455

Copyright ©2018 Northern Lights, Inc.  
All rights reserved. Northern Lights™, and  
the Northern Lights logo are trademarks of  
Northern Lights, Inc.

Printed in U.S.A.  
PART NO.: OM864W 07/18



# OPERATOR'S MANUAL

## for Models M864W and M864W3

Read this operator's manual thoroughly before starting to operate your equipment.  
This manual contains information you will need to run and service your new unit.

### Table of Contents

<b>INTRODUCTION</b>		
Models Included .....	2	
Model Numbers .....	2	
Serial Numbers .....	2	
<b>WARRANTY</b> .....	3	
<b>SAFETY RULES</b> .....	3 - 8	
<b>COMPONENT LOCATIONS</b>		
M864 Generator Set .....	10 - 11	
<b>CONTROL PANELS</b>		
Northern Lights Generator Sets .....	12	
<b>OPERATING PROCEDURES</b>		
Break-in Period .....	13	
Before Starting .....	13	
Starting .....	14	
Operating .....	14	
Stopping .....	15	
Shutdowns and Alarms .....	15	
Spare Parts .....	15	
<b>SERVICING SCHEDULE CHART</b>	16 - 17	
<b>SERVICING</b>		
Lubrication - General .....	18	
Checking Oil .....	18	
Oil Changes .....	18	
Changing Oil Filter .....	19	
Air Filter .....	19	
<b>SERVICING (Continued)</b>		
V-Belts .....	19	
Valve Clearances .....	20	
Fuels - General .....	21	
Fuel Filters .....	21	
Bleeding the Fuel System .....	22	
Injector Service .....	23	
Injection Pump .....	24 - 25	
Cooling System .....	26	
Heat Exchanger .....	27	
Raw Water Pump .....	27	
Zinc Electrodes .....	27	
Electrical System - General .....	28	
Booster Batteries .....	28	
Battery Care .....	29	
Winterizing / Out-of-Service .....	29	
<b>TROUBLESHOOTING</b>		
Electrical .....	30	
Engine .....	31 - 33	
<b>DATA SHEET</b>		
Specifications and Dimensions .....	34	
<b>WIRING DIAGRAMS</b>		
AC Electrical .....	35 - 36	
DC Electrical .....	37 - 44	
Panel Diagrams .....	45 - 51	

#### Proprietary Information

This publication is the property of Northern Lights, Inc.  
It may not be reproduced in whole or in part without the written permission of Northern Lights, Inc.  
© Northern Lights, Inc. All rights reserved. Litho U.S.A. Publication number OM864W 1/18

## Introduction

The servicing of marine engines and generator sets presents unique problems. In many cases, boats cannot be moved to a repair facility. Marine engines cannot be compared to the servicing of automobiles, trucks, or even farm equipment. Failures often occur in remote areas far from competent assistance. Marine engines are taxed far more severely than auto or truck engines; therefore, maintenance schedules must

be adhered to more strictly. Failures begin with minor problems that are overlooked and become amplified when not corrected during routine maintenance.

As operator, it is your obligation to learn about your equipment and its proper maintenance. This is not a comprehensive technical service manual. Nor will it make the reader into an expert mechanic. Its aim is to aid you in maintaining your unit properly.

## Unit Identification

### MODELS INCLUDED

This manual covers the operating instructions for:

**M864W AND M864W3** marine generator sets, which use the 864 engine block.

## Model Numbers

Model numbers give the unit's application, block model, aspiration, and RPM:

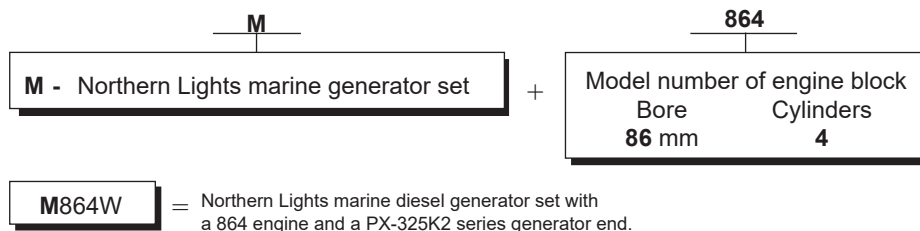

## Serial Numbers

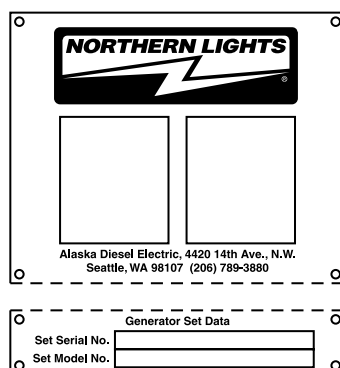

Your set has three serial numbers: ① an engine number stamped on a plate attached to the valve cover, ② a generator end serial number, and ③ a generator set serial number.

NOTE: Always use the generator set serial number when ordering parts or in correspondence. The generator set serial number plate is found on the service side of the generator and resembles the drawing in Figure 1.

*Figure 1: Generator set serial number plate.*

A warranty registration certificate is supplied with your set. It entitles the original purchaser of our equipment to a warranty covering material or assembly faults. The extent of coverage is described in the Limited Warranty Statement. We recommend that you study the statement carefully.

**NOTE:** If the warranty is to apply, the servicing instructions outlined in this manual must be followed. If further information is needed, please contact an authorized dealer or the factory.

**Safety Rules**

***DANGER: Northern Lights generator sets and /or any other diesel powered equipment provided by NLI is not provided with spark arresting or explosion proof components, and therefore is not to be installed in the presence of combustible gases having a flash point of 43.3 Degrees C (110 Degrees F) or lower, such as Gasoline, Propane, Natural Gas or other similar fuel sources.***



**NOTICE:** Accident reports show that careless use of engines causes a high percentage of accidents. You can avoid accidents by observing these safety rules. Study these rules carefully and enforce them on the job.

**IMPORTANT SAFETY INSTRUCTIONS.**

Electromagnetic equipment, including generator sets and their accessories, can cause bodily harm and life threatening injuries when improperly installed, operated or maintained. To prevent accidents be aware of potential dangers and act safely.



**READ AND FOLLOW ALL SAFETY INSTRUCTIONS IN THIS MANUAL, PRIOR TO THE INSTALLATION OF ANY GENERATOR SET OR ACCESSORY. KEEP THESE INSTRUCTIONS FOR FUTURE REFERENCE.**

**Recognize Safety Symbols and Instructions**

In addition to the information found in this section, this operator's manual uses three different signal words to outline potential dangers of a specific nature.

	<b>DANGER</b> DANGER indicates a hazardous situation which, if not avoided, will result in death or serious injury.
	<b>WARNING</b> WARNING indicates a hazardous situation which, if not avoided, could result in death or serious injury.
	<b>CAUTION</b> CAUTION indicates a hazardous situation which, if not avoided, could result in minor or moderate injury.

**Follow All Safety Instructions**

Carefully read and understand all safety messages in this manual and on your machine's safety signs. Keep signs in good and clean condition. Replace missing or damaged signs. Be sure new equipment components and



repair parts include the current safety signs. For replacement signs, proper placement of safety signs or clarification on any safety issue, consult your Northern Lights dealer or the factory.

There can be additional safety information contained on parts and components from outside suppliers that is not reproduced in this manual. Consult the suppliers for additional safety information.

Learn how to operate the machine and how to use the controls properly. Only trained personnel should operate machines, or work on or around them.

Keep you machine in proper working condition. **UNAUTHORIZED MODIFICATIONS TO THE MACHINERY MAY IMPAIR ITS FUNCTION AND SAFETY PARAMETERS.**

**Prevent Bypass and Accidental Starting**



**! WARNING**

Do not start engine by shorting across start terminal. Engine will start if normal circuitry is bypassed, creating a hazard by runaway machinery.

Start engine only from operator's station.

## Safety Rules (Continued)

### Handle Fuel Safely - Avoid Flames

#### **! WARNING**

Diesel is highly flammable and should be treated with care at all times. Do not refuel while smoking or when near sparks or open flame.

#### ALWAYS STOP ENGINE BEFORE FUELING

MACHINE. Always fill portable fuel tank outdoors.

Never fuel a hot engine.

Prevent accidental discharge of starting fluids by storing all cans in a cool, safe place, away

from sparks or open flame. Store with cap securely on container. Never incinerate or puncture a fuel container.



Prevent fires by keeping machine clean of accumulated trash, grease and debris. Always clean any spilled fuel as swiftly as possible. Do not store oily rags, which can ignite and burn spontaneously.

Be prepared if a fire starts. Keep a first aid kit and fire extinguisher handy. Keep emergency contact numbers for fire department, doctors, ambulance and hospital near the telephone.

### Service Machines Safely

#### **! DANGER**

Do not wear a necktie, scarf, necklace, rings or other jewelry, or any loose clothing when working near moving parts. Tie long hair behind your head. If any of these items get caught in moving machinery, severe injury or death could result.

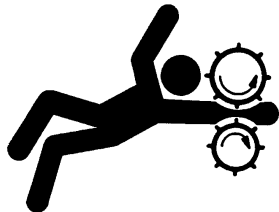

Check for any loose electrical connections or faulty wiring.

Look completely around engine to make sure that everything is clear before starting.

### Wear Protective Clothing

#### **! WARNING**

To prevent catching anything in moving machinery, always wear close fitting clothes and safety equipment appropriate to the job.

Prolonged exposure to loud noise can cause hearing loss or impairment. Wear suitable authorized hearing protection, such as earmuffs or plugs to protect against loud noises.

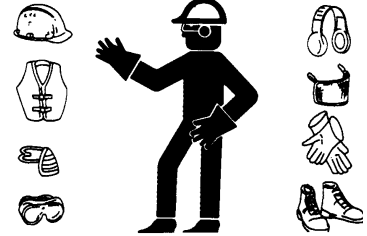

Operating equipment requires the full attention of the operator. Do not use radio or music headphones while operating machinery.

### Practice Safe Maintenance

#### **! CAUTION**

Understand all service procedures before starting work. Keep area clean and dry. Never lubricate, service, or adjust machine while it is in operation.



Keep hands, feet and clothing away from power-driven equipment. When shutting down an engine, disengage all power and operator controls. Allow the engine to cool completely before beginning any service work.

*Securely support any machinery elements that must be raised for service work with support or lifting machinery specifically intended for that purpose.*

Keep all parts in good conditions and properly installed. Fix damage immediately. Replace any worn or broken parts. Remove any build up of grease, oil or debris.

Disconnect battery ground cable (-) before making any adjustments or service work.

**Safety Rules (Continued)****Stay Clear of Rotating Drivelines****! DANGER**

Entanglement in rotating drivelines can cause serious injury or death. Keep shields in place at all times. Make sure that rotating shields turn freely in pace with the drivelines.



Do not wear loose fitting equipment around rotating drivelines. Stop the engine and make sure that all moving parts have stopped before making any adjustments, connections, or performing any other type of service to the engine or other driven equipment.

**Install all Safety Guards****! WARNING**

Direct contact with rotating fans, belts, pulley and drives can cause serious injury.

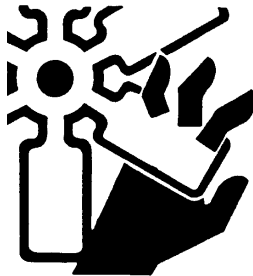

Keep all guards in place at all times during engine operation.

Wear close-fitting clothes. Stop the engine and be sure all fans, belts, pulleys and drives are stopped before making adjustments, connections, or cleaning near fans and their components.

Do not allow anything on your person to dangle into or come in contact with a moving fan, belt, pulley or drive. Fans can act as vacuums and pull materials up from below, so avoid that area as well while in service.

**Safe Battery Handling****! WARNING****Prevent Battery Explosions**

Battery gas is highly flammable. Battery explosions can cause severe injury or death. To help prevent battery explosions, keep sparks, lighted matches and open flame away from the top of battery. When checking battery electrolyte level, use a flashlight.

Never check battery charge by contacting the posts with a metal object. Use a voltmeter or hydrometer.

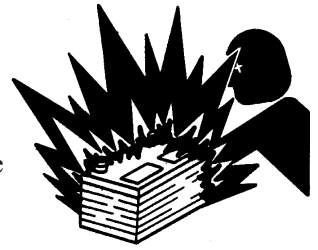

Frozen batteries may explode if charged. Never charge a battery that has not been allowed to warm to at least 16°C (60°F).

Always remove grounded (-) battery clamp first and replace ground clamp last.

Sulfuric acid in battery electrolyte is poisonous and strong enough to burn skin, eat holes into clothing and other materials, and cause blindness if splashed into eyes.

**To Avoid Hazards:**

- Fill batteries only in well-ventilated areas.
- Wear appropriate eye protection and rubber gloves.
- Never use air pressure to clean batteries.
- Wear appropriate ventilation equipment to avoid inhaling fumes when adding electrolyte.
- Do not spill or drip electrolyte.
- Use correct jump-start procedure if required.

**If acid is spilled on skin or in eyes:**

1. Flush skin with water.
2. Apply baking soda or lime to help neutralize acid.
3. Flush eyes with water for 15-30 minutes.
4. Get medical attention immediately.

**If acid is swallowed:**

1. DO NOT induce vomiting.
2. Drink large amounts of water or milk, without exceeding 2 liters (2 quarts)
3. Get medical attention immediately

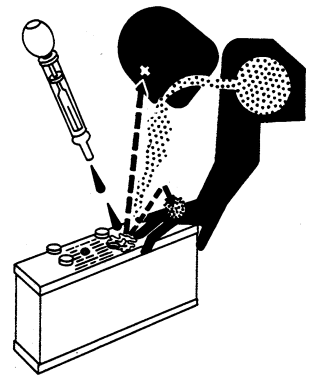
**! WARNING**

Battery posts, terminals, and related accessories can contain lead and lead compounds, chemicals known to the State of California to cause cancer and reproductive harm. Wash hands after handling.

## Handle Chemical Products Safely

### **! WARNING**

Direct exposure to hazardous chemicals can cause serious injury. Among the potentially hazardous chemicals that may be used with Northern Lights products are lubricants, coolants, paints and adhesives.

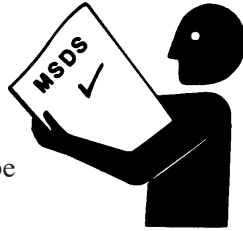

All potentially hazardous chemicals come with a Material Data Safety Sheet (MSDS). The MSDS provides specific details on chemical products, including physical hazards, safety procedures and emergency response techniques

Read and understand the MSDS for each chemical before you start any job that includes it. Follow the procedures and use appropriate equipment exactly as recommended.

Contact your Northern Lights dealer or Northern Lights factory for MSDS's used on Northern Lights products.

## Work in Well Ventilated Areas

### **! CAUTION**

Exhaust fumes from engines contain carbon monoxide and can cause sickness or death. Work in well ventilated areas to avoid prolonged exposure to engine fumes. If it is necessary to run an engine in an enclosed area, route the exhaust fumes out of the area with an approved, leak proof exhaust pipe extension.

## Remove Paint Before Welding or Heating

### **! WARNING**

Hazardous fumes can be generated when paint is heated by welding, soldering or using a torch. To avoid potentially toxic fumes and dust, remove paint before heating.



- Remove paint a minimum of 100 mm (4 in.) from the area that will be affected by heat.
- If paint cannot be removed, wear an approved respirator.
- If you sand or grind paint, use an approved respirator.
- If you use solvent or paint stripper, remove stripper with soap and water before welding. Remove solvent or paint stripper containers from the area.
- Allow at least 15 minutes for fumes to disperse before welding or heating.

Do not use a chlorinated solvent in an area where welding will occur. Work only in areas that are well ventilated. Dispose of paint and solvent properly.

## Service Cooling System Safely

### **! WARNING**

Opening a pressurized cooling system can release explosive fluids and causing serious burns. Before opening any pressurized cooling system, make sure the engine has been shut off. Do not remove a filler cap unless it is cool enough to comfortably grip with bare hands. Slowly loosen cap to relieve pressure before opening fully.



## Avoid High Pressure Fluids

### **! WARNING**

Relieve pressure prior to disconnecting pressurized lines. Escaping fluid under pressure can penetrate the skin causing serious injury. Always relieve pressure before disconnecting hydraulic or other pressurized lines. Tighten all connections firmly before re-applying pressure.



If searching for leaks, use a piece of cardboard. Always protect your hands and other body parts from high-pressure fluids.

If an accident occurs, see a doctor immediately. Any high pressure spray injected into the skin must be removed within a few hours to prevent the risk of gangrene or other infection.

## Avoid Heating Near Pressurized Fluid Lines

### **! WARNING**

Flammable spray can be generated by heating near pressurized fluid lines, resulting in severe burns and bodily injury. Pressurized lines can rupture when heat goes beyond the immediate flame area. Do not weld, solder or use a torch or open flame near pressurized lines or other flammable fluids.





### Do Not Open High-Pressure Fuel System

#### **DANGER**

 Many Northern Lights engines use high-pressure fuel injection. High-pressure fluid remaining in fuel lines can cause serious injury. Do not disconnect or attempt any repair of fuel lines, sensors, or other components between the high-pressure fuel pump and nozzles on engines with high pressure fuel systems.

**ONLY AUTHORIZED TECHNICIANS CAN PERFORM REPAIRS ON AN HIGH PRESSURE FUEL INJECTION SYSTEMS.**

### Avoid Hot Exhaust

#### **WARNING**

Avoid exposure to and physical contact with hot exhaust gases. Exhaust parts and streams can reach high temperatures during operation, leading to burns or other serious injury.



Cleaning exhaust filters can also lead to exposure to hot exhaust gas and the injury risk associated with it. Avoid exposure to and physical contact with hot exhaust gases when cleaning exhaust filters.

During auto or manual/stationary exhaust filter cleaning operations, the engine will run at elevated temperatures for an extended period of time. Exhaust parts and streams can reach high temperatures during operation, leading to burns or other serious injury.

### Avoid Harmful Asbestos Dust

#### **WARNING**

Inhaling asbestos fibers may cause lung cancer. Avoid breathing any dust that may be generated when handling components containing asbestos fibers, including some gaskets.



The asbestos used in these components is usually found in a resin or otherwise sealed. Normal handling of these components is not dangerous, as long as airborne dust containing asbestos is not generated.

Avoid creating dust. Never use compressed air for cleaning. Avoid brushing or grinding materials containing asbestos. When servicing, wear an approved respirator. A special vacuum cleaner is recommended to clean asbestos. If this vacuum is not available, apply a mist of oil or water on the material containing asbestos. Keep all bystanders away from any area where asbestos dust may be generated.

### Use Proper Lifting Equipment and Techniques

#### **WARNING**

Lifting heavy components incorrectly can cause severe injury or damage to machinery. Avoid unbalanced loads. Do not use lifting eyes. Lift the generator set using lifting bars inserted through the lifting holes on the skid. Follow all recommended removal and installation procedures in this and associated Northern Lights manuals.



### Use Proper Tools

#### **CAUTION**

Makeshift tools and procedures can create safety hazards. Always use appropriate tools for the job.



Use power tools only to loosen threaded parts and fasteners. For loosening and tightening hardware, always use the correct sized tools.

Do not use US measurement tools on metric fasteners, or vice versa. Use only service parts that meet Northern Lights specifications.

### Dispose of Waste Properly

#### **CAUTION**

Disposing of waste improperly can threaten the environment and lead to unsafe working conditions. Potentially harmful waste used in Northern Lights equipment can include oil, fuel, coolant, filters and batteries.

Use leakproof containers to drain fluid. Do not use food or beverage containers that may mislead someone into drinking from them.

Do not pour waste onto the ground, down a drain or into any water source.

## Lock Out / Tag Out Procedures

### Scope

During maintenance, repairs or retooling of a Northern Lights generator set, simply turning the machine off or unplugging it while it is being worked on does not give enough protection to others who are not performing the maintenance or repair. Many serious accidents happen when someone thought the machine was turned off, or all of its energy was safely blocked or released.

### General Policy

#### CAUTION

To avoid dangerous or hazardous situations, refrain from any of the following:

- Removing or bypassing a guard or other safety device
- Placing any part of your body in a position where you could be caught by moving machinery.
- Cleaning or oiling machinery when in operation.
- Adjusting circuits, chillers, pumps, air handlers, valves, circuit breakers or fans while in operation.
- Working on piping or high pressure systems.

### Lock Out/Tag Out Instructions - Electrical Equipment

#### WARNING

Be sure the equipment's ON/OFF switch is in the OFF position and is unplugged from any electrical source before attempting to perform any type of work on the equipment. Obtain an electrical plug cap cover with a lockset. Secure the plug terminal end using the electrical plug lockout cap. Lock the cap and retain the key.

If the equipment is directly wired into an electrical box with a shut off switch, obtain a lock pad and/or the appropriate colored tags and place the lock and tag through the shut off lever. Retain the key until the repair is completed and the machine is safe to start. Be certain the shut off lever is in the OFF position before restarting. NEVER give a lock out key to unauthorized personnel.

If the equipment is directly wired into an electrical box without a shut off switch and lock out capability, then a circuit breaker lock out will be required. Obtain a circuit lock and tag set. Install the lock onto the circuit breaker box. Ensure the unit ON/OFF switch is in the OFF position before restarting.

### Lock Out/Tag Out Instructions - Pneumatic and Hydraulic Equipment

#### WARNING

For servicing pneumatic and hydraulic equipment, the following additional procedures must be implemented, following completion of lock out/tag out procedures for the unit to be serviced:

Shut off air, water or supply valves at the equipment to be serviced.

Check the local bleed-off point for completed release of pressurized air, water or oil.

If shutting off of air, water or other material cannot be achieved at the local supply valve, shut off valves further back in the system and re-check the bleed-off point until complete shut-off is achieved.

Affix a DO NOT OPERATE tag to each valve handle that requires shut off. Each DO NOT OPERATE tag must be signed and dated by the authorized technician servicing the equipment.

### Lock Out/Tag Out Instructions - Air Hose Connected Pneumatic Equipment

#### WARNING

Equipment connected to the compressed air system through an air hose with a detachable fitting must be shutdown and unplugged. Excess air must be bled prior to removing the air hose, prior to any maintenance or repair activities.

Affix a DO NOT OPERATE tag to the air hose near the detachable fitting. Each DO NOT OPERATE tag must be signed and dated by the authorized technician servicing the equipment. Check that the equipment cannot be operated by activating the ON switch.

### Stored Energy

#### WARNING

Immediately after applying Lock Out or Tag Out devices, ensure that all potentially hazardous stored or residual energy is relieved, disconnected, restrained and otherwise rendered safe.

### Verification of Isolation

#### CAUTION

Verify the machinery or equipment is actually isolated and de-energized prior to beginning work on a machine or on equipment that has been locked out.

### Restarting Procedures

#### CAUTION

Follow the procedures below prior to restoring energy:

- Ensure that all machinery or equipment is properly reassembled. Inspect the machinery or equipment to verify non-essential items have been removed.
- Ensure that all personnel are safely outside danger zones. Notify personnel that lock out/tag out devices have been removed and energy will be reapplied.
- Only authorized personnel may remove lock out/tag out devices or notices.



## Generator Component Locations

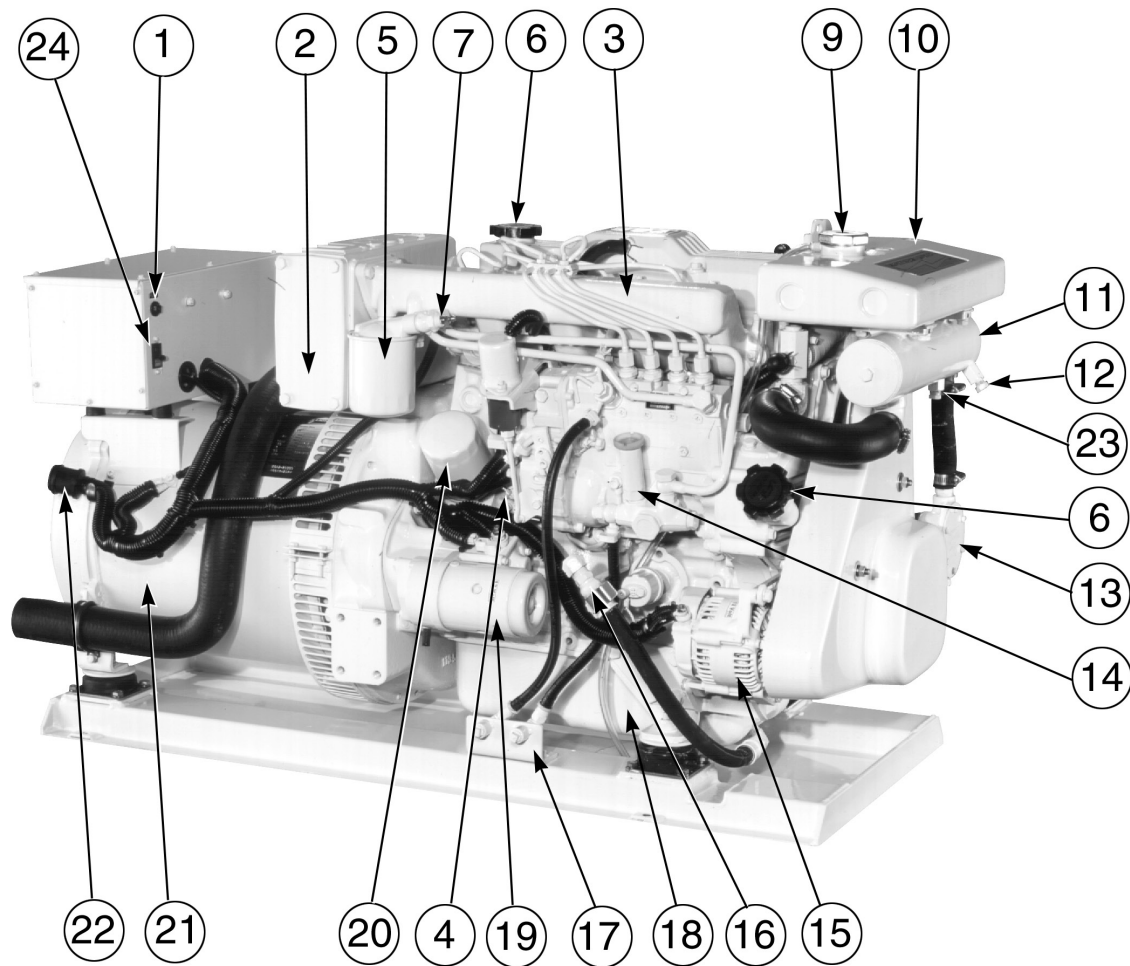

**Figure 2:** M864 Service Side

- |                            |   |                    |                                      |
|----------------------------|---|--------------------|--------------------------------------|
| 1. DC Circuit Breaker      | 9. Coolant Fill                             | 15. DC Alternator  | 22. DC Panel Plug-In                 |
| 2. Air Filter              | 10. Expansion Tank                          | 16. Lube Oil Drain | 23. Heat Exchanger Fresh Water Drain |
| 3. Intake Manifold         | 11. Heat Exchanger                          | 17. Fuel Manifold  |                                      |
| 4. Lube Oil Dipstick       | 12. Heat Exchanger Raw Water Drain and Zinc | 18. Oil Pan        |                                      |
| 5. Secondary Fuel Filter   | 13. Raw Water Pump                          | 19. Starter        |                                      |
| 6. Lube Oil Fill           | 14. Fuel Primer Pump                        | 20. Oil Filter     |                                      |
| 7. Fuel System Bleed Point |   | 21. AC Generator   |                                      |

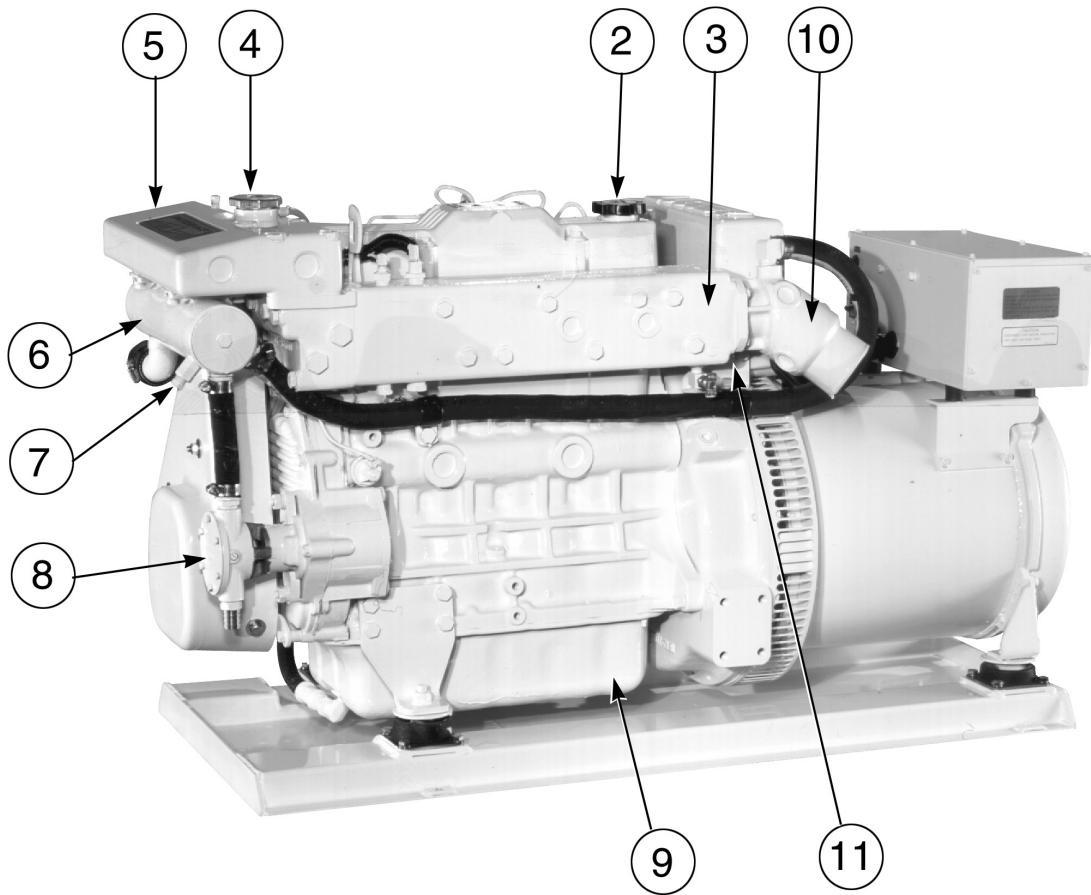

*Figure 3: M864 Non-Service Side*

- |                     |  |
|---------------------|--|
| 2. Lube Oil Fill    | 7. Heat Exchanger Raw Water Drain and Zinc |
| 3. Exhaust Manifold | 8. Raw Water Pump                          |
| 4. Coolant Fill     | 9. Oil Pan                                 |
| 5. Expansion Tank   | 10. Wet Exhaust Elbow                      |
| 6. Heat Exchanger   | 11. Manifold Drain                         |

## Control Panels

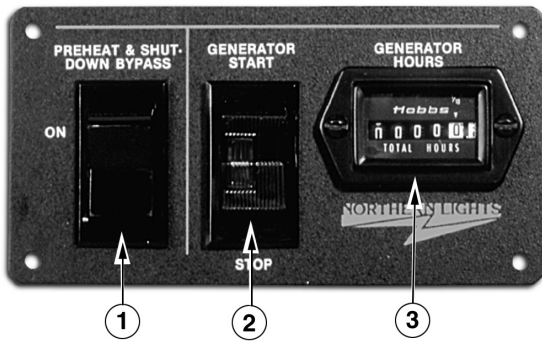

Figure 4-A: Series 1-B Generator Control Panel



Figure 4-B: Series 3 Generator Control Panel



Figure 4-C: Series 4 Generator Control Panel

### 1. PREHEAT/ SHUTDOWN BYPASS

- This switch serves two functions:
- Preheats engine before beginning the starting process. Press switch for 10-20 seconds before attempting startup.
  - Bypasses the safety shutdown feature during the starting process. Keep switch engaged while starting engine, and for 2 to 3 seconds afterwards, allowing oil pressure to build beyond shutdown setpoint.

### 2. ENGINE CONTROL SWITCH

To start the engine, hold this switch in the START position until the engine is running. After the engine starts, release the switch and it will return to RUN position. To stop the engine, hold the switch in the STOP position.

**NOTE:** The rocker switch is used on Series 1 panels only, and has a light that glows when the set is running.

### 3. HOUR METER

Keeps track of engine running time.

### 4. OIL PRESSURE GAUGE

Shows the oil pressure in the engine lubricating system.

### 5. WATER TEMPERATURE GAUGE

Registers the temperature of the cooling water.

### 6. D.C. VOLTMETER

When the engine is stopped, the voltmeter indicates the condition of the battery. When the engine is running, the voltmeter indicates the voltage output of the alternator.

**For Series 4 Control Panels only:**

### 7. A.C. VOLTMETER

Shows the generator output voltage.

### 8. FREQUENCY METER (Hertz)

The frequency meter indicates alternating current frequency: 60 Hz (1800 RPM) or 50 Hz (1500 RPM).

### 9. AMMETER/VOLTMETER SELECTOR

Used to check the voltage and current of each phase. Return to "Amps Off" position when not monitoring.

### 10. A.C. AMMETER

Shows the generator load on each phase. The phase is selected with the Ammeter Selector switch (#9).

### BREAK-IN PERIOD

1. The first 100 hours on a new or reconditioned engine are critical to its life and performance.
2. Constantly check the engine temperature and oil pressure gauges.
3. Oil consumption is greater during break-in as piston rings take time to seat.
4. Break-In Oil Changes: Change engine oil and filter at 50 hours. Change oil and filter again at 100 hours (consult Lubricants section for oil recommendation).

#### Operating Instructions:

Maintain at least a 75% load on your generator set for the first 100 hours. If this is not possible, maintain no less than a 50% load to ensure proper seating of the piston rings. Vary the load to help seat the rings.

### BEFORE STARTING

1. Check the water level by removing the pressure cap from the expansion tank. In order to give the cooling water an opportunity to expand, the level should be about 1 in. (2.5 cm) below the filler cap sealing surface when the engine is cold.



---

**CAUTION:** Use protective clothing and open the filler cap carefully when the engine is warm to prevent burns.

---

2. Check the oil level in the crankcase with the dipstick. The oil level must be between high and low marks on the stick. Never allow the level to go below this area. Always add the same viscosity of oil as is already in the crankcase.
3. Check the fuel tank level and open any fuel valves on the tank and at the secondary fuel filter.
4. Close the sea-cock, check and clean the sea strainer, and re-open the sea-cock.
5. Place the battery switch in the ON position.

**NOTE:** The battery switch must always be kept ON while the engine is running. If the switch is turned OFF while the engine is running, the battery charging alternator could be damaged.

## Operating Procedures

### STARTING

1. Hold the Shutdown Bypass switch in the ON position for 10-20 seconds before starting.  
NOTE: Holding the switch too long can burn out the glow plugs.
2. While holding the Shutdown Bypass switch in the ON position, push the Engine Control switch to the START position.
3. As soon as the engine starts, release both switches. Do not crank the starter for more than 20 seconds consecutively. If the engine fails to start with the first attempt, be sure that it has stopped completely before re-engaging the starter.

**NOTE: Excessive cranking of the starter on marine sets equipped with a water lift muffler can cause engine damage. If the engine does not start after 3 consecutive 20-second cranks, remove the impeller from the seawater pump. This will prevent the muffler from filling with water and backfilling the exhaust line and engine. Once the engine starts, shut it off immediately and reinstall the impeller.**

**Restart and check the exhaust overboard outlet for gushes of water.**

### OPERATING

1. Units with Series 3 and Series 4 Control Panels: Check gauges often. Oil pressure must be above 15 PSI. The D.C. voltmeter should read between 11 and 15 volts at 80° F (25° C) ambient temperature. The water temperature gauge must be below 200° F (94° C). Check the A.C. voltage and frequency meters (Series 4 panel). If the gauges deviate from normal levels, shut down the generator set and investigate.
2. Let the unit run unloaded for a three to five minute warm-up period.
3. Add electrical load.

### STOPPING

1. Remove electrical load from the generator set.
2. Run the engine for a three to five minute cool-down period.
3. Move the Engine Control switch to the STOP position until the engine stops completely.
4. Shut off seacock, fuel valve, and battery switch.



## SHUTDOWNS AND ALARMS

1. Your unit is fitted with a system to protect it from high water temperature or low oil pressure.
  - a. Generator sets have shutdown systems to stop the engine. They have no warning horns.
  - b. Other alarms and shutdowns are available as optional equipment.

**NOTE: If your unit is equipped with optional shutdowns and alarms, do not rely on the warning or shutdown system to the exclusion of careful gauge monitoring. Watching your gauges can prevent damage to the unit and dangerous power losses.**

2. Do the following when your warning or shutdown system is activated:
  - a. Check the temperature gauge. If above 205° F (96° C), shut off the engine immediately.
  - b. Use the Trouble Shooting Guide on page 26 to isolate the cause of the overheat.



***CAUTION: Do not remove the water fill cap of an overheated engine. Escaping high temperature steam can cause severe burns. Allow the engine to cool and then remove the cap slowly using protective clothing.***

- c. Make repairs and restart after the temperature gauge registers below 200° F (94° C).
  - d. Watch the temperature gauge regularly and turn off the unit if the temperature rises above 205° F (96° C). Repeat troubleshooting.
3. If shutdown is activated and the temperature gauge shows temperature within normal temperature range:
  - a. Check the engine crankcase oil level.
  - b. If the oil level is low, fill with recommended lubricating oil and restart. Watch the oil pressure gauge carefully and shut off the engine if it does not show a normal reading (20-60 PSI) after a few seconds of operation.
  - c. If the oil level is normal, DO NOT restart the engine. Call your dealer for assistance.

## SPARE PARTS

1. ADE recommends that you keep the following spare parts on hand for field service. The parts are available from your local Northern Lights dealer. Some marine models may already have “On-Board Kits,” a handy box that contains the most common parts you will need.
  - a. Primary and secondary fuel filter elements
  - b. Oil filters
  - c. Air filter elements
  - d. Alternator belt
  - e. Thermostat and gaskets
  - f. Seawater pump impeller and gaskets
  - g. Glow plugs
  - h. Injector and washer
2. If your set is operating a long distance from a servicing dealer, add the following:
  - a. Complete set of injectors
  - b. Copper washers for injector change
  - c. Complete set of glow plugs
  - d. Fuel lift pump

## Servicing Schedule Chart

The Servicing Schedule Chart below shows the service schedule required for proper maintenance of your generator set. More detailed coverage of each Service Point (SP) is listed on the page noted in the 'page' column.

**DAILY:**

- SP1 Check oil level in engine
- SP8 Check primary fuel filter
- SP14 Check cooling water level  
Check sea strainer

- SP4 Check air cleaner
- SP9 Change primary fuel filter element
- SP10 Change secondary fuel filter
- SP18 Check zinc electrodes

**AFTER FIRST 50 HOURS:**

- SP2/3 Change engine oil and filter
- SP5 Check V-belt tension
- SP7 Adjust valves
- SP19 Check electrolyte level in batteries

**EVERY 750 HOURS:**

- SP7 Check valve clearances
- SP12 Check injectors
- SP15 Check and flush cooling system
- SP17 Change impeller
- SP20 Check state of charge of batteries

**EVERY 50 HOURS:**

- SP5 Check V-belt tension
- SP19 Check electrolyte level in batteries

**EVERY 1500 HOURS:**

- SP12 Check injectors, clean tips

**AFTER FIRST 100 HOURS:**

- SP2/3 Change engine oil and filter

**EVERY 2400 HOURS:**

- SP13 Check fuel injection pump
- SP16 Check and clean heat exchanger

**EVERY 200 HOURS:**

- SP2/3 Change engine oil and filter

**EVERY 3000 HOURS:**

- SP12 Remove injectors for adjustment, clean & repair

SERVICE POINT	PAGE	OPERATION	DAILY	50 Hours	100 Hours	200 Hours	750 Hours	1500 Hours	2400 Hours	3000 Hours
<b>ENGINE:</b>										
SP1	12	Check oil level	•							
SP2	12	Change engine oil <sup>1, 5</sup>			•	•				
SP3	13	Change lube oil filters <sup>1, 5</sup>			•	•				
SP4	13	Check air cleaner <sup>1, 4</sup>				•				
SP5	13	Check V-belt tension <sup>1</sup>		•						
SP7	14	Check valve clearances <sup>5</sup>					•			
<b>FUEL SYSTEM:</b>										
SP8	15	Check primary filter <sup>2</sup>	•							
SP9	15	Change primary filter element <sup>2, 3</sup>				•				
SP10	15	Change secondary fuel filter <sup>1, 3</sup>				•				
SP11	16	Bleed the fuel system <sup>3</sup>								
SP12	17	Check injectors <sup>1, 6</sup>					•	•		•
SP13	18	Check fuel injection pump							•	
<b>COOLING SYSTEM:</b>										
SP14	20	Check cooling water level	•							
SP15	20	Check and flush cooling system					•			
SP16	21	Check and clean heat exchanger							•	
SP17	21	Change impeller in raw water pump <sup>1, 3</sup>					•			
SP18	21	Check zinc electrodes <sup>4</sup>				•				
<b>ELECTRICAL SYSTEM:</b>										
SP19	23	Check electrolyte level in batteries <sup>1, 4</sup>		•						
SP20	23	Check condition of batteries with hydrometer <sup>1</sup>					•			
<b>OUT OF SERVICE:</b>										
SP23	23	Winterizing or out-of-service <sup>3</sup>								

1) Perform all maintenance once a year even if hour level has not been reached.  
 2) Consult manufacturer's maintenance schedule, note on chart.  
 3) Whenever necessary.  
 4) More often if necessary.  
 5) After first 50 hours.

6) To insure that your engine stays in compliance with applicable EPA & CARB emission standards, the following additional maintenance procedures & intervals must be maintained.  
 1500 Hours: Fuel injectors are to be removed & injector tips cleaned.  
 3000 Hours: Fuel injectors removed for adjustment, cleaning, & repair.

## Service Record

Service Point	OPERATION	HOURS/ DATE									
<b>50 HOURS</b>											
SP5	Check V-belt tension										
SP19	Check electrolyte in batteries										
<b>200 HOURS</b>											
SP2	Change engine oil										
SP3	Change lubricating oil filters										
SP4	Check air cleaner										
SP8	Change primary filter element (Racor)										
SP10	Change secondary fuel filter										
SP18	Check zinc electrodes										
<b>EVERY 750 HOURS</b>											
SP7	Check valve clearances										
SP12	Check injectors										
SP15	Check and flush cooling system										
SP17	Change impeller in seawater pump										
SP20	Check condition of batteries with hydrometer										
<b>1500 HOURS</b>											
SP12	Check injectors, clean tips										
<b>2400 HOURS</b>											
SP13	Check fuel injection pump										
SP16	Check and clean heat exchanger										
SP22	Check and clean oil cooler on reverse gear										
<b>3000 HOURS</b>											
SP12	Clean and repair injectors										

## LUBRICATION - GENERAL

1. Use only clean, high quality lubricants stored in clean containers in a protected area.
2. These lubricants are acceptable:
  - a. API Service CC/CD/CE single viscosity oils.
  - b. API Service CC/CD/CF multi-viscosity oils.
3. Use the proper weight oil for your average operation temperature.

Air Temperature	Single Viscosity	Multi-Viscosity
Above 32° F (0° C)	SAE 30W	SAE 15-40W
-10° to 32° F (-23° to 0° C)	SAE 10W	SAE 10-30W

**Figure 5:** Lube Oils

4. Never put additives or flushing oil in crankcase.

## SP1. CHECKING OIL LEVEL

1. While the engine is stopped, check the oil level in the crankcase with the dipstick daily. The oil level must be between the high and low marks on the stick. Fill with the recommended oil, and fill only to the high mark on the dipstick. Follow the lubrication recommendations in Figure 5.

## SP2. OIL CHANGES

1. The set is delivered with special break-in oil. Change the engine oil and oil filter after 50 hours of operation. Use Service CC 30 weight oil during the first 100 hours.
2. Change the oil and filter again at 100 hours using the oil recommended in the above diagram. After this, change oil and filter every 200 hours.
3. During intermittent cold weather operation, change oil every 100 hours or six weeks, whichever comes first.
4. Change oil at any seasonal change in temperature when a new viscosity of oil is required.
5. Change oil when engine is warm but not hot.
6. Dispose of waste oil in an approved manner.
7. Never use a flushing oil.
8. Remove cap. Drain oil. Replace cap and tube.
9. Refill engine with recommended oil.
10. Engine capacity with new oil filter is:  
 Model 864W & W3.....7.8 qts. (7.4 liters)

## SP3. CHANGING LUBE OIL FILTER

1. Change the lube oil filter every 200 hours.
2. Use a filter wrench to remove old filter. Dispose of filter in approved manner.
3. Make sure the gasket from the old filter is removed and discarded. Clean mount face.
4. Spread a thin film of engine oil on the rubber gasket on the new filter and screw it on nipple until gasket meets the sealing surface.
5. Using hands only – no wrench – tighten filter one-half turn farther. Overtightening can do damage to filter housing.
6. Fill engine with recommended oil. Start engine and check for leakage. Stop engine, wait 3 minutes, and check oil level. Add additional oil if necessary.
7. Oil filter part number is:  
Model 864W & W3.....#24-08701.

## SP4. AIR CLEANER

1. Visually inspect air cleaner every 200 hours. In dusty conditions, check more often.
2. Remove the plate on the side of the air intake manifold. Remove and inspect the foam element. If dirty, wash element in soapy water. Rinse and dry thoroughly before reinstalling.

**NOTE: Make absolutely sure no impurities enter the engine while changing the element, and do not run the engine with the air cleaner removed.**

**Do not clean the filter with diesel fuel, solvent, or gasoline. Serious engine damage can result.**

## SP5. V-BELTS

1. Check the tension and wear on the V-belt after every 50 hours.
2. Use your thumb to press on the belt at the midpoint between the crankshaft and alternator pulleys. The tension is correct if the belt can be depressed about 3/8 in. (10 - 15 mm) with 22 lbs. (10 kg) force.

## SP7. VALVE CLEARANCES

1. Readjust valve clearance after first 50 hours of operation. Adjust valves every 750 hours thereafter.
2. Warm up the engine to 167° F - 185° F (75° C - 85° C). Shut off fuel and battery.
3. Rotate the crankshaft in a clockwise direction to set cylinder No. 1 to the top dead center. Top dead center (TDC) is when notch "TDC" on the pulley aligns with the pointer and the two valves on cylinder No. 4 "rock". Rocking is when the rocker arms (for the two valves on a given cylinder) are moving in opposite directions, one up closing the valve and one down opening the other valve. The moment when the two rocker arms are exactly aligned with each other is when they "rock".

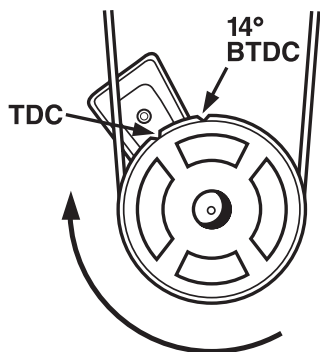



Figure 6: Timing Marks

4. Measure the valve clearance for each of the valves (shown as  in Figure 7). Standard valve clearances for a hot engine are:  
 Intake (IN)..... 0.007 - 0.009 in. (0.18 - 0.22 mm)  
 Exhaust (EX)..... 0.013 - 0.015 in. (0.33 - 0.37 mm)





-  Adjustable when cylinder No. 1 is at Top Dead Center (TDC)
-  Adjustable when cylinder No. 4 is at Top Dead Center (TDC)

Figure 7: Valve Sequence

5. To adjust valve clearance, loosen the lock nut on the adjustment screw. Insert a feeler gauge between the rocker arm and the valve stem cap. Adjust until the feeler gauge slides with a slight drag. Tighten the lock nut and recheck the clearance (Figure 8).

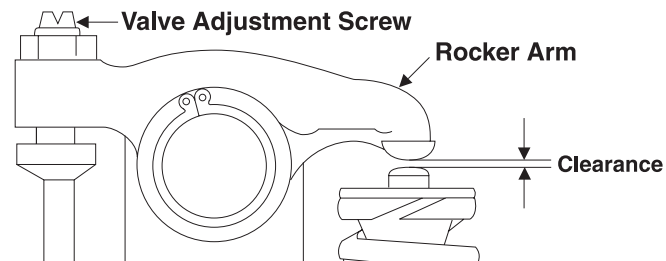



Figure 8: Valve Adjustment

6. Rotate the crankshaft in clockwise direction one full turn to set cylinder No. 4 to top dead center (TDC). Adjust the remaining valves (shown as  in Figure 7).
7. Replace the rocker arm cover.

**FUELS - GENERAL**

1. Use only clean, high quality fuels of the following specifications, as defined by ASTM designation D975 for diesel fuels:
  - a. Use grade No. 2 diesel at ambient temperatures above freezing 32° F (0° C).
  - b. International fuel specifications:  
ISO-8217-DMA  
BS 2869 Part 1 Class A1  
BS 2869 Part 2 Class A2
2. Use fuel having less than 1% sulphur (preferably less than 0.5%).
3. The cetane number should be a minimum of 45.
4. DO NOT use these unsuitable grades of fuel:
  - a. Domestic heating oils, all types.
  - b. Class B engine.
  - c. Class D domestic fuels.
  - d. Class E, F, G or H industrial or marine fuels.
  - e. ASTM-D975-60T No. 4-D and higher number fuels.
5. Biodiesel:

Biodiesel involves the transesterification of vegetable oils or animal fats. It can involve animal fats, yellow greases (used greases), cotton seed, sunflower seed, coconut oil, or sesame seed, but mainly in the US soybean methyl ester is used (SME). In Europe mainly rapeseed (canola) methyl ester is made (RME), and in Asia palm methyl ester (PME) is made. 100% biodiesel (B100) is made in compliance with ASTM D6751 or EN14214 (EU) specifications.

Biodiesel may be used in a 5% blend (5% biodiesel/ 95% diesel) from a BQ-9000 accredited producer. 20% biodiesel blends (20% biodiesel/ 80% diesel) can only be used if they meet ASTM D6751 or EN14214 (EU) specifications. A 2% reduction in power and a 3% reduction in fuel economy can be expected if a 20% blend is used. With a 20% biodiesel blend, an approved fuel conditioner is recommended. The petroleum part of the biodiesel blend must meet ASTM D975 or EN590 (EU) specifications. Biodiesel blends must be used within 90 days of their manufacture. When biodiesel blends are used the oil level must be checked daily and storage, leaking, possible microbial growth, plugging, and components degradation must all be checked more frequently.

**Note:** *Using raw pressed or partially refined vegetable oils or recycled greases as fuel (which have not been through transesterification) could cause engine failure.*

Request a certificate of analysis from an approved biodiesel fuel distributor to make sure the biodiesel blend meets specifications.

6. Storing fuel:
  - a. Keep dirt, scale, water, and other foreign matter out of fuel.
  - b. Avoid storing fuel for long periods of time.
  - c. Fill the fuel tank at the end of each day's operation. This will reduce condensation.

**SP8-10. FUEL FILTERS**

1. Your generator set should have a primary fuel filter installed. We recommend the Northern Lights brand of fuel filter-water separators.
  - a. Check the primary fuel filter daily as recommended by the filter manufacturer. Empty the collection bowl as necessary.
  - b. Change the element as often as necessary or every 200 hours.
  - c. If the bowl fills with water, change the primary and secondary element immediately.

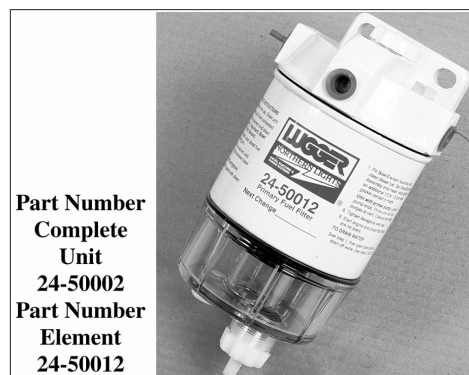

**Part Number  
Complete  
Unit  
24-50002  
Part Number  
Element  
24-50012**

**Figure 9:** Primary Fuel Filter

2. Change secondary fuel filter every 200 hours.

**NOTE:** The fuel filter on the engine is considered the “secondary fuel filter”.

- a. Remove the spin-on filter by turning it counter-clockwise with a filter wrench. Fill the new cartridge with fuel and install it after applying engine oil to the gasket surface. Screw on the filter until the gasket surface comes into contact with the sealing surface of the filter base. Then, tighten it two-thirds of a turn by hand. Do not overtighten.
- b. Fuel filter part number is:  
Model 864W & W3.....#24-52020

### SP11. BLEEDING THE FUEL SYSTEM



**CAUTION:** Escaping diesel fuel under pressure can penetrate skin causing serious personal injury. Before disconnecting lines be sure to relieve all pressure. Before applying pressure, be sure all connections are tight and lines, pipes and hoses aren't damaged. Fuel escaping from a very small hole can be almost invisible. Use a piece of cardboard or wood, rather than hands, to search for suspected leaks. If injured by escaping fuel, see a doctor at once. Serious infection or reaction can develop if proper medical treatment isn't administered immediately.

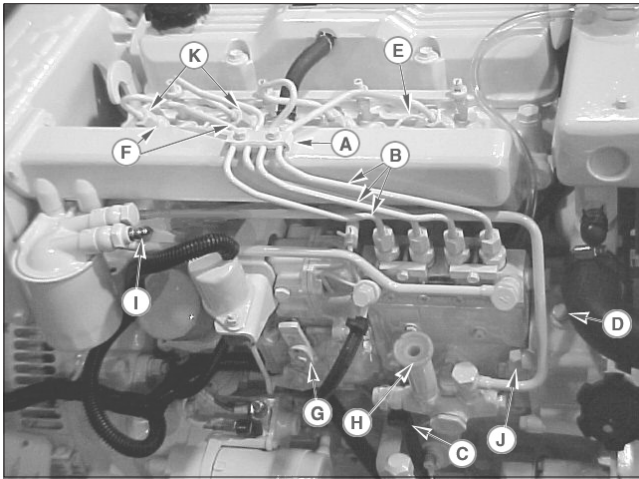

Figure 10: Fuel System

1. The fuel system is self-bleeding. However, any system may need manual bleeding when:
  - a. A new fuel filter is installed;
  - b. The engine has run out of fuel;
  - c. The fuel lines, injection pump or any other fuel system component has been removed and installed.
2. Loosen bleed nipple (Figure 10-I) on top of the fuel filter. Pump hand primer (Figure 10-H) on fuel lift pump until pure fuel (no bubbles) escapes from the bleed nipple (Figure 10-I). Tighten bleed nipple.
3. If the engine does not start after this bleeding process, loosen a fuel line at the injector (Figure 10-F) while cranking the engine with the starter motor until pure fuel escapes. Then tighten the connection. Do each line **one-at-a-time**.
4. After the engine has started, use a piece of cardboard to look for fuel leaks.



**SP12. INJECTOR SERVICE**

1. Injectors should be checked every 750 hours. This check should be made by a Northern Lights dealer or local injection repair station.

To insure that your engine stays in compliance with applicable EPA and CARB emission standards, the following maintenance procedures and intervals must be maintained.

1500 Hours: Fuel injectors are to be removed and injector tips cleaned.

3000 Hours: Fuel injectors removed for adjustment, cleaning, and repaired.



**CAUTION:** Escaping diesel fuel under pressure can have sufficient force to penetrate the skin causing serious personal injury. If injured by escaping fuel, see a doctor at once.

2. Injector Removal:

- a. Clean loose dirt from around the injectors and the fuel lines.
- b. Relieve high pressure in the fuel lines by loosening the delivery line flare nuts at each injector.

- c. Remove delivery lines (Figure 12-B) by disconnecting from injectors and injection pump. Remove all lines as an assembly; do not remove the spacers. Cover the ends of the lines, the injector inlets and injection pump outlets to keep dirt out.
- d. Remove the return line retaining nuts, washers, and return line.
- e. Loosen the injector (Figure 12-I). Remove the injector.
- f. Remove the injector seat. Cover the holes to prevent debris from entering the cylinders.

**NOTE:** Do not use pry bars to remove injectors from the cylinder head.

3. Injector Repair and Cleaning

- a. Take injectors to your Northern Lights dealer or local injection repair station for testing and service.

4. Injector Installation:

- a. Install new injector seal washer seat and injector. Tighten the injector (Figure 11-1) to 42 - 50 ft/lbs. (5.8 - 6.9 k/gm). Do not overtighten.
- b. Reinstall the return line (Figure 11-4) using new sealing washers (Figure 11-2). Tighten bolts (Figure 11-3) to 18 - 25 ft/lbs (2.5 - 3.5 k/gm).

**NOTE:** Overtightening can damage injectors.

- c. Reinstall injection lines (Figure 12-B). Tighten flare nuts (Figure 12-K) at injection pump to 18.2 - 25.3 ft/lbs (2.5 - 3.5 k/gm). Leave the lines loose at injectors for bleeding.
- d. Bleed the injection lines (Figure 12-B). Crank the engine to fill the lines. Tighten flare nuts at injectors to 18.2 - 25.3 ft/lbs (2.5 - 3.5 k/gm).
- e. Start the engine and check for leaks using a piece of paper or cardboard. Do not use your hand to check for leaks.

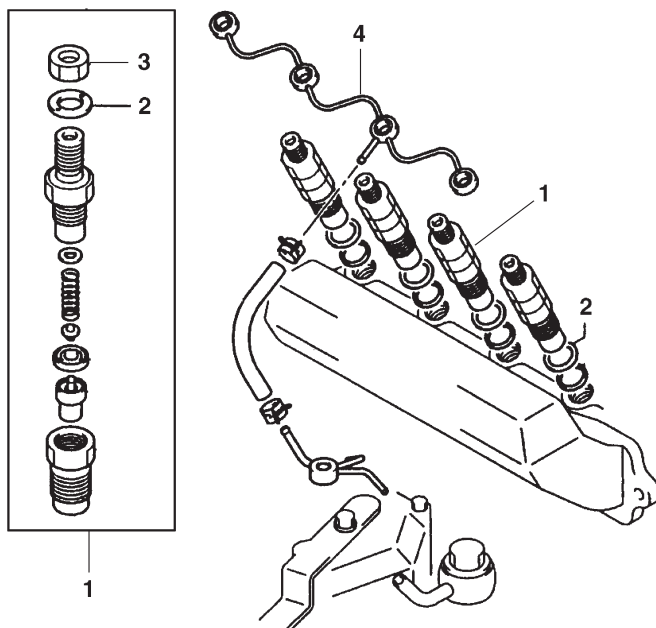
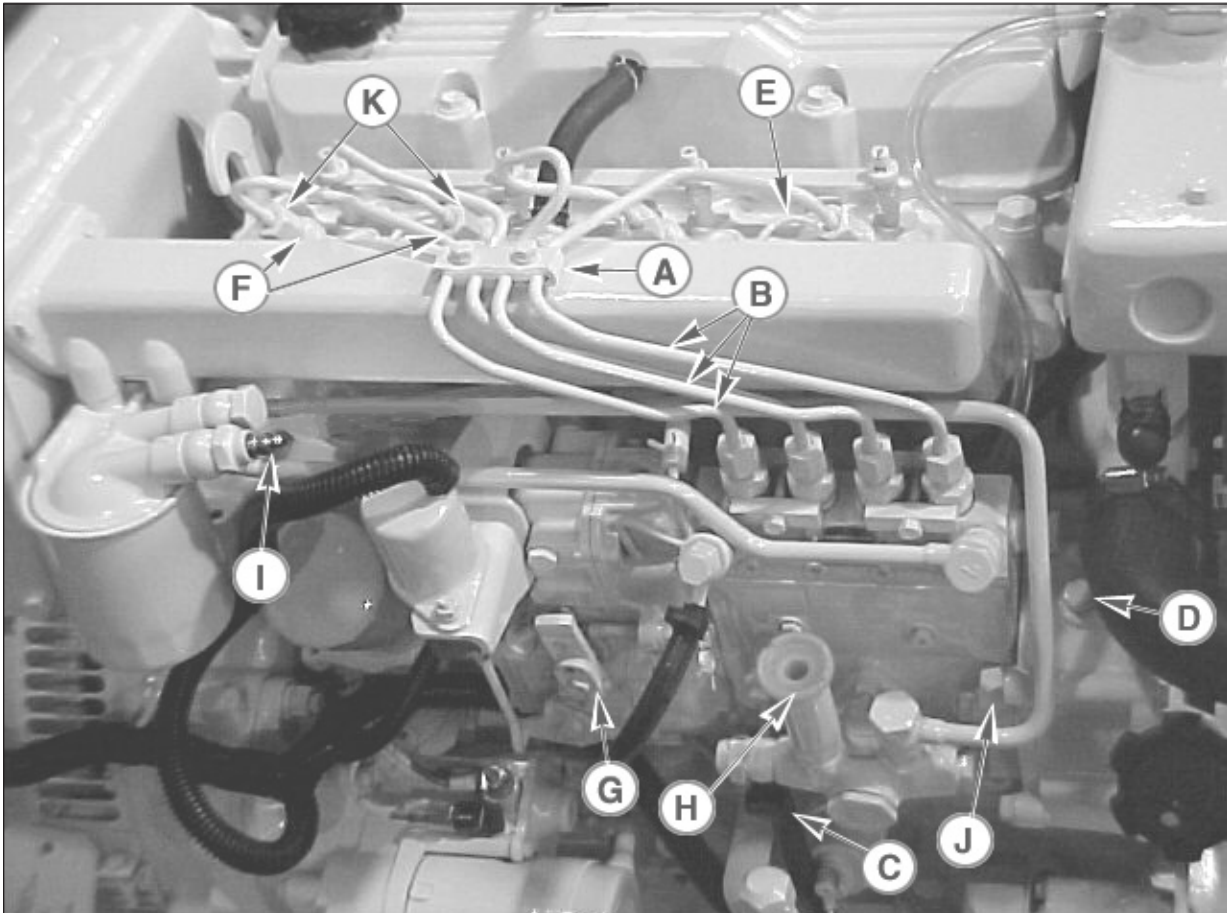

Figure 11: Injectors

### SP13. INJECTION PUMP

1. Since operating conditions may vary considerably, it is difficult to give a definite interval for checking the injection pump. But as a rule, pump settings, maximum speed, idle speed and exhaust smoke should be checked after every 2400 hours of operation. Service of the fuel injection pump should only be done if checks indicate pump malfunction.
2. Black smoke can be an indication of pump malfunction. Before servicing the pump, check other possible causes:
  - a. Check cleanliness of the air filter.
  - b. Check valve clearances.
  - c. Clean and check injectors.
3. Any repair which involves disassembly of the injection pump must be carried out by specially trained mechanics with the proper tools and test equipment.

**NOTE: All warranties on the engine become null and void if the injection pump seals are broken by unauthorized persons.**



*Figure 12: Fuel System*

- |                                 |                            |                             |                              |
|---------------------------------|----------------------------|-----------------------------|------------------------------|
| <b>A.</b> Injection Line Clamps | <b>D.</b> Timing Mark Plug | <b>G.</b> Throttle Lever    | <b>J.</b> (4) Mounting Bolts |
| <b>B.</b> Fuel Injection Lines  | <b>E.</b> Fuel Return Line | <b>H.</b> Hand Priming Pump | <b>K.</b> Flare Nuts         |
| <b>C.</b> Fuel Feed Line        | <b>F.</b> Injector (4)     | <b>I.</b> Air Vent Point    |                              |

4. Injection Pump Removal:



**CAUTION:** Escaping diesel fuel under pressure can have sufficient force to penetrate the skin, causing serious personal injury. If injured by escaping diesel fuel, see a doctor at once.

- a. Clean the injection pump, hoses, and area around the pump with a cleaning solvent or steam cleaner.

**NOTE:** Never steam clean or pour cold water on an injection pump while the engine is running or the pump is warm.

- b. Remove the injection lines (Figure 12-B) from the pump and injectors. Remove all lines as an assembly. Do not remove the spacers. Cover the ends of the lines, the injector inlets, and the injection pump outlets to keep dirt out of the injectors, lines, and pump.
- c. Remove the plug (Figure 12-D) from the timing case cover. Use an indelible marker to put a mark on the injection pump gear through the plug hole. You will use this mark to align the pump during reassembly. Do not rotate the crankshaft after marking.
- d. Remove the 4 mounting nuts (Figure 12-J). One (1) is found on the back side of the injection pump, and three (3) are found on the front side.
- e. Take the pump to your Northern Lights dealer or an injection repair station for testing and service.

5. Injection Pump Installation:

- a. Reverse the removal process.
- b. Make sure the mark on the gear shows through the plug hole.
- c. Torque mounting bolts to 12 - 18 ft/lbs (1.7 - 2.5 k/gm).

**INJECTION PUMP TIMING**

1. The injection pump is timed at the factory and the pump body and mounting flange are marked. If pump timing is questionable, follow the procedure below.
2. Check Injection Pump Timing:
  - a. Bleed air from the fuel system (see page 16).
  - b. Remove the fuel injection line from the No. 1 fuel delivery valve on the injection pump (Figure 13).

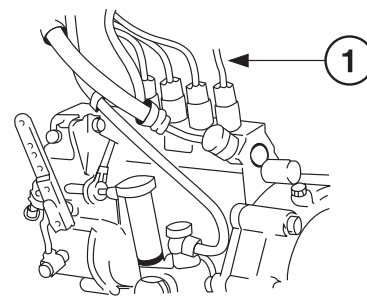

Figure 13: Fuel Injection Lines

- c. Pressurize the system with the hand primer pump (Figure 12-H).
- d. Slowly rotate the crankshaft by hand in clockwise direction until fuel just begins to rise in the No. 1 delivery valve.
- e. The crankshaft pulley notch mark for 13° Before Top Dead Center (BTDC) should now align with the timing pointer (Figure 14). If it does not, the injection pump needs to be timed.

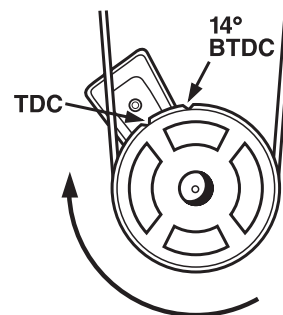

Figure 14: Timing Marks

### COOLING SYSTEM - GENERAL

**NOTE:** Be sure to close the sea-cock before working on the engine cooling system.



**CAUTION:** *The cooling water in the engine reaches extremely high temperatures. You must use extreme caution when working on hot engines to avoid burns. Allow the engine to cool before working on the cooling system. Open the filler cap carefully, using protective clothing when the engine is warm.*

### SP14. CHECK THE COOLANT LEVEL

1. Check the coolant level each day before starting the engine.
  - a. Check the water level by removing the pressure cap from the radiator. In order to give the cooling water an opportunity to expand, the level should be about 1 in. (2.5 cm) below the filler cap sealing surface when the engine is cold.
  - b. The pressure valve in the filler cap releases when the pressure is approximately 7 PSI (0.5 kg/cm<sup>2</sup>). Use a cap pressure tester to check cap if you suspect it is faulty.

### SP15. COOLING SYSTEM FLUSHING

1. Flush the cooling system every 750 hours or every 12 months, whichever comes first.
2. Remove fill cap and open drains on engine block. The hex-headed engine block drain is on the service side of the engine below the intake manifold, next to the flywheel housing.
3. Pour clean water into the engine until water coming from engine is clear of discoloration. Close drains and refill the engine with recommended coolant mixture.
4. Use 50% water / 50% ethylene glycol antifreeze mix. Antifreeze mixture is recommended as a good year-round coolant.
5. Check hoses and connections and repair any leakage.
6. Start the engine and check for leaks. Run the engine for five minutes, then shut it down. Let engine cool, and then check the coolant level in the engine. Add coolant as needed.

**NOTE:** Be sure to open the sea-cock after working on the engine cooling system and starting the engine.

## SP16. HEAT EXCHANGER

1. Clean the heat exchanger core once a year or after 2400 hours of operation.
2. Drain the expansion tank and heat exchanger.
3. Remove the heat exchanger end covers.
4. Clean the inside of the exchanger core tubes using a metal rod. Flush, inspect, and clean again if necessary.
5. Reassemble the heat exchanger. Fill the cooling system. Start the engine and check for leaks.

## SP17. RAW WATER PUMP

1. Change the raw water pump impeller every 750 hours, or as needed.
2. Remove the pump cover. Pry out the impeller using needle-nose pliers or two screwdrivers. Be sure to remove all pieces of the failed impeller.

**NOTE: Place some kind of protection under the screwdrivers in order to not damage the pump housing.**

3. Clean the inside of the housing.
4. Press in the new impeller and place the sealing plug in the outer end of the impeller center if this has not already been done.

**NOTE: Make sure that there is always an extra impeller and cover gasket in reserve on board.**

## SP18. ZINC ELECTRODES

1. A zinc electrode is installed in the heat exchanger cooling system to protect the engine from electrolysis. Check it faithfully every 200 hours. If you are in warm saltwater, or where electrolysis is a known problem, check it more often.
2. Remove the zinc holder from the bottom of the exchanger (Figure 2-12). This will drain raw water from the exchanger.
3. Scrape or steel brush the zinc electrode clean. If more than 50% of the electrode is corroded away, replace it with a new zinc. The electrode screws out of the holder.
4. Reinstall the zinc holders. Be sure the threads are clean for good metal-to-metal contact. Do not use thread sealant.
5. Refill the cooling system. Start the engine and check for leaks.

## PTO

Check the manufacturer's manual for servicing requirements for the Optional PTO with electric clutch.

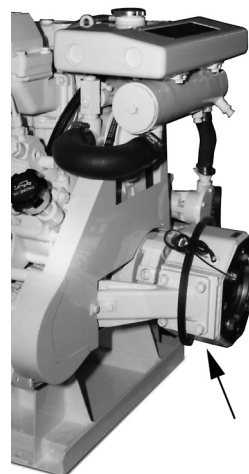

*Figure 15: Optional PTO with electric clutch*

### GENERATOR END

The maintenance and operation recommendations for the generator end are in a separate Owner's Manual. If you do not have one of these manuals, contact your local dealer.

### ELECTRICAL SYSTEM - GENERAL

1. Never switch the battery switch off or break the circuit between the alternator and the batteries while the engine is running. Alternator damage can result.
2. Do not reverse the polarity of the battery cables when installing the battery.

### BOOSTER BATTERIES



**CAUTION:** Battery gas can explode. Keep all flames and sparks away from batteries.

1. Before changing or using booster batteries, check the battery electrolyte level. Add distilled water if necessary.
2. Booster and main batteries must have the same voltage rating.
3. First, connect the positive (+) terminal of the booster battery to the positive (+) terminal of the main battery. Then, connect the negative (-) terminal of the booster battery to ground on the engine block (Figure 16).
4. Remove the booster battery after starting the engine.
5. Sealed Batteries:  
See the manufacturer's charging and booster instructions.

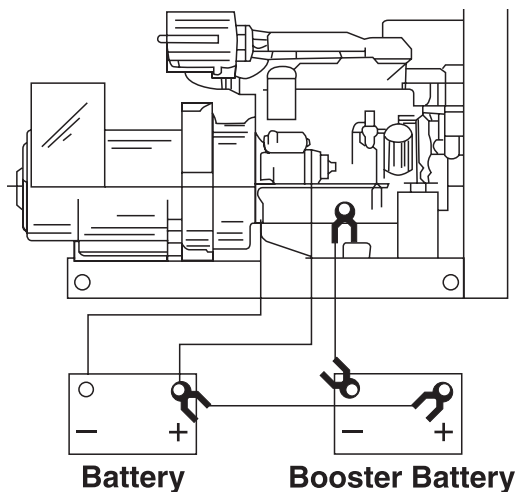

*Figure 16: Booster Battery Connections*

## SP19-20. BATTERY CARE

1. Check the electrolyte level every 50 hours, or once a month. Add distilled water to the manufacturer's recommended level.
2. Batteries, cables, and cable terminals should be checked and cleaned every 100 hours. Clean corrosion with a water and baking soda solution. Flush with clean water. Tighten terminals and grease them to inhibit future corrosion.
3. Check the battery condition with a hydrometer every 750 hours.

## SP23. WINTERIZING / OUT-OF-SERVICE

**NOTE: Remember to close the sea-cock before opening drain cocks.**

1. Change the crankcase oil and filter.
2. Drain fresh water and seawater cooling systems completely. Flush fresh water systems and refill with the proper antifreeze mixture.
3. Drain the water supply lines and wet exhaust line.
4. Loosen the seawater pump cover and drain the pump.
5. Loosen the alternator belt.
6. Disconnect and clean the battery. Remove the battery to a warm storage place if possible.
7. Clean the outside of the unit. Paint any scratched or chipped surfaces. Put corrosion preventative on all exposed metal surfaces.

## Troubleshooting

### DC ELECTRICAL SYSTEM

PROBLEM	POSSIBLE CAUSE	RECOMMENDATION(S)
<b>Battery Will Not Charge</b>	Loose or corroded connections	• Clean and tighten battery connections.
	Sulfated or worn out batteries	• Check specific gravity of each battery. • Check electrolyte level of each battery.
	Loose or defective alternator belt	• Adjust belt tension. • Replace belt.
<b>Starter Inoperative</b>	Check DC circuit breaker	• If the breaker is tripped, reset it.
	Loose or corroded connections	• Clean and tighten loose battery and harness plug connection.
	Low battery condition	• Check specific gravity of each battery. • Check electrolyte level of each battery.
	Defective electrical system ground wire:	• Repair or replace.
<b>Starter Cranks Slowly</b>	Low battery condition	• Battery is too small. • Battery cables are too small.
	Check specific gravity of each battery	• Replace battery if necessary.
	Check electrolyte level of each battery	• If low, fill cells with distilled water.
	Crankcase oil too heavy	• Fill with oil of appropriate viscosity.
	Loose or corroded connections	• Clean and tighten loose connections.
<b>Entire Electrical System Does Not Function</b>	Check DC circuit breaker	• If breaker is tripped, reset it.
	Faulty connection	• Clean and tighten battery and harness plug connections.
	Sulfated or worn out batteries	• Check specific gravity and electrolyte level of each battery.

If you cannot correct problems with these procedures, see your **Northern Lights** dealer.



## ENGINE

PROBLEM	POSSIBLE CAUSE	RECOMMENDATION(S)
<b>Engine Hard to Start or Will Not Start</b>	Improper starting procedure	<ul style="list-style-type: none"> <li>• See starting section of this manual. Take special note of Bypass Switch operation.</li> </ul>
	No fuel	<ul style="list-style-type: none"> <li>• Check level of fuel in fuel tank.</li> </ul>
	Low battery condition	<ul style="list-style-type: none"> <li>• Check electrolyte level and condition.</li> </ul>
	Excessive resistance in starting circuit	<ul style="list-style-type: none"> <li>• Clean and tighten all battery connections.</li> </ul>
	Crankcase oil too heavy	<ul style="list-style-type: none"> <li>• Use oil of proper viscosity.</li> </ul>
	Improper type of fuel	<ul style="list-style-type: none"> <li>• Consult fuel supplier and use proper type of fuel for operating condition.</li> </ul>
	Water, dirt or air in fuel system	<ul style="list-style-type: none"> <li>• Drain, flush, fill and bleed system.</li> </ul>
	Clogged primary fuel filter element	<ul style="list-style-type: none"> <li>• Clean or replace filter element.</li> </ul>
<b>Engine Runs Irregularly or Stalls Frequently</b>	Clogged secondary fuel filter element	<ul style="list-style-type: none"> <li>• Replace filter element.</li> </ul>
	Dirty or faulty injection nozzles	<ul style="list-style-type: none"> <li>• Have your dealer check injection nozzles.</li> </ul>
	Below normal engine temperature	<ul style="list-style-type: none"> <li>• Remove and check thermostat.</li> </ul>
	Clogged primary fuel filter element	<ul style="list-style-type: none"> <li>• Clean or replace filter element.</li> </ul>
	Clogged secondary fuel filter element	<ul style="list-style-type: none"> <li>• Replace secondary filter element.</li> </ul>
	Water or dirt in the fuel system	<ul style="list-style-type: none"> <li>• Drain, flush, fill and bleed system.</li> </ul>
	Dirty or faulty injection nozzles	<ul style="list-style-type: none"> <li>• Have your dealer check injection nozzles.</li> </ul>
	Air in fuel system	<ul style="list-style-type: none"> <li>• Inspect clamps and hoses on suction side of fuel pump for air leak.</li> </ul>
<b>Lack of Engine Power</b>	Improper type of fuel	<ul style="list-style-type: none"> <li>• Consult fuel supplier and use proper type of fuel for operating condition.</li> </ul>
	Engine overloaded	<ul style="list-style-type: none"> <li>• Reduce the load.</li> </ul>
	Intake air restriction	<ul style="list-style-type: none"> <li>• Service air cleaner.</li> </ul>
	Clogged primary fuel filter element	<ul style="list-style-type: none"> <li>• Clean or replace filter element.</li> </ul>
	Clogged secondary fuel filter element	<ul style="list-style-type: none"> <li>• Replace filter element.</li> </ul>
	Overheated engine	<ul style="list-style-type: none"> <li>• See “Engine Overheats” in next category.</li> </ul>
	Improper type of fuel	<ul style="list-style-type: none"> <li>• Consult fuel supplier and use proper type of fuel for operating conditions.</li> </ul>
	Below normal engine temperature	<ul style="list-style-type: none"> <li>• Remove and check thermostat.</li> </ul>
	Improper valve clearance	<ul style="list-style-type: none"> <li>• Reset valves. Best done by dealer.</li> </ul>
Dirty or faulty injection nozzles	<ul style="list-style-type: none"> <li>• Replace injectors. Best done by dealer.</li> <li>• See your local dealer.</li> </ul>	

## Troubleshooting

### ENGINE

PROBLEM	POSSIBLE CAUSE	RECOMMENDATION(S)
<b>Engine Overheats</b>	Engine overloaded	• Reduce the electrical load.
	Low coolant level	• Fill tank or radiator to proper level. • Check hoses for loose connections and leaks.
	Keel cooling tubes (marine sets) have been painted	• Remove paint from tubes.
	Cooling system needs flushing	• Flush cooling system.
	Defective thermostat	• Remove and check thermostat.
	Defective temperature gauge	• Check water temperature with thermometer and replace gauge if necessary.
	Water pump impeller worn or broken	• Check the impeller and replace if necessary.
<b>Engine Knocks</b>	Insufficient oil	• Call your dealer.
	Injection pump out of time	• Call your dealer.
	Below normal engine temperature	• Check your thermostats. • Check water temperature to see if temperature gauge is working properly.
	Faulty fuel injector	• Call your dealer.
	Engine overheating	• See “Engine Overheating” section.
<b>High Fuel Consumption</b>	Improper type of fuel	• Use correct fuel for temperature.
	Clogged or dirty air cleaner	• Service air cleaner.
	Engine overloaded	• Reduce the electrical load.
	Improper valve clearance	• See your dealer.
	Injection nozzles dirty	• See your dealer.
	Injection pump out of time	• See your dealer.
	Engine not at proper temperature	• Check your thermostats. • Check water temperature with thermometer and replace gauge if necessary.
<b>Below Normal Engine Temperature</b>	Thermostats not working properly	• Check thermostats.
	Temperature gauge not working properly	• Check water temperature with thermometer.
<b>Low Oil Pressure</b>	Low oil level	• Fill crankcase to proper level.
	Improper type of oil	• Drain and fill crankcase with correct oil.
	Partially plugged oil filter	• Replace filter.

If you cannot correct problems with these procedures, see your **Northern Lights** dealer.

### ENGINE

PROBLEM	POSSIBLE CAUSE	RECOMMENDATION(S)
<b>High Oil Consumption</b>	Break-in period	• Oil consumption decreases after break in.
	Crankcase oil too light	• Use proper viscosity oil.
	Oil leaks	• Check for leaks in lines around gaskets and drain plug.
	Crankcase over full	• Remove excess oil.
<b>Engine Emits Black or Gray Exhaust Smoke</b>	Clogged or dirty air cleaner	• Service air cleaner.
	Defective muffler (back pressure too high)	• Have dealer check back pressure.
	Improper fuel	• Use correct fuel for temperature.
	Engine overloaded	• Reduce the electrical load.
	Injection nozzles dirty	• See your dealer.
	Engine injection timing off	• See your dealer.
<b>Engine Emits White Smoke</b>	Improper fuel	• Use correct fuel for temperature.
	Cold engine	• Warm up engine to normal operating temperature.
	Defective thermostat	• Remove and check thermostat.
	Engine injection timing off	• See your dealer.
	Low Compression Pressure	• See your dealer.

If you cannot correct problems with these procedures, see your **Northern Lights** dealer.

## Specifications and Dimensions

Rated RPM/Frequency Kilowatt Rating	1800/60 Hz 25 kW	1500/50 Hz 20 kW
<b>General Information</b>		
Cylinders	In-line 4	In-line 4
Displacement	151.7 CID (2.49 l)	151.7 CID (2.49 l)
Cycle	4	4
Bore x Stroke	3.39 in (86 mm) x 4.21 in (107 mm)	3.39 in (98 mm)x 4.21 in (107 mm)
Rotation (Facing Flywheel)	counterclockwise	counterclockwise
Compression Ratio	21.5:1	21.5:1
Crankcase Capacity (Including Oil Filter)	7.8 qts. (7.4 l)	7.8 qts. (7.4 l)
Aspiration	Natural	Natural
Flywheel Housing Size	SAE 4	SAE 4
Flywheel Drive Size	SAE C-110	SAE C-110
Dry Weight Complete Unit with Heat Exchanger Cooling	3 $\phi$ - 980 lbs., 1 $\phi$ - 965 lbs.	3 $\phi$ - 980 lbs., 1 $\phi$ - 965 lbs.
Height	26.88 in (683 mm)	26.88 in (683 mm)
Width	20.75 in (527 mm)	20.75 in (527 mm)
Length	47.0 in (1194 mm)	47.0 in (1194 mm)
<b>Cooling System</b>		
Approximate Cooling System Capacity with Heat Exchanger	2.2 gal (8.3 ltr)	2.2 gal (8.3 ltr)
Minimum Through-Hull Diameter	.75 in (19 mm)	.75 in (19 mm)
Sea Water Pump Inlet Hose (Inside Diameter)	.75 in (19 mm)	.75 in (19 mm)
Minimum Sea Water Discharge	.75 in (19 mm)	.75 in (19 mm)
Heat Rejection to Jacket Water	1788 BTU/min	1400 BTU/min
Fresh Water Pump Capacity	11.5 gal/min (43.5 l/m)	9.5 gal/min (36 l/m)
Maximum Sea Water Pump Suction Head	39 in (1 m)	39 in (1 m)
Keel Cooler Tube Length (Turbo Tube)	8 ft (2.44 m)	8 ft (2.44 m)
Keel Cooler Head Diameter	1.25 in (32 mm)	1.25 in (32 mm)
Keel Cooler Water Hose ID Discharge and Suction	1.5 in (38 mm)	1.5 in (38 mm)
<b>Electrical</b>		
Minimum Battery Capacity	220 Amp/hour - 640 CCA	220 Amp/hour - 640 CCA
Battery Cable Size	#1/0 up to 10 ft (3 m)	#1/0 up to 10 ft (3 m)
Instrument Harness Length	20 ft (6.1 m)	20 ft (6.1 m)
Starting Voltage, Negative Ground	12 VDC	12 VDC
<b>Air</b>		
Generator Cooling Air Flow, 3 $\phi$ & 1 $\phi$	292 cfm (8.3 m <sup>3</sup> /m)	225 cfm (6.4 m <sup>3</sup> /m)
Air Consumption	67.2 cfm (1.89 m <sup>3</sup> /m)	54 cfm (1.53 m <sup>3</sup> /m)
Maximum Engine Room Vent	39 sq in (193 cm <sup>2</sup> )	39 sq in (193 cm <sup>2</sup> )
Maximum Exhaust Back Pressure	48 in. H <sub>2</sub> O (1219 mm H <sub>2</sub> O)	48 in. H <sub>2</sub> O (1219 mm H <sub>2</sub> O)
Wet Exhaust Elbow OD	3 in (75 mm)	3 in (75 mm)
<b>Fuel</b>		
Minimum Suction Line	3/8 in (10 mm)	3/8 in (10 mm)
Minimum Return Line	3/8 in (10 mm)	3/8 in (10 mm)
Maximum Fuel Transfer Pump Suction	39 in (100 mm)	39 in (100 mm)
Specific Fuel Consumption at Maximum Load	0.414 lbs/hp/hr	0.409 lbs/hp/hr
Approximate Fuel Rate at Maximum Load	2.3 gal/h (8.7 l/hr)	1.8 gal/h (6.8 l/hr)

NOTE: Specifications are subject to change without notice.

# AC Wiring Diagram

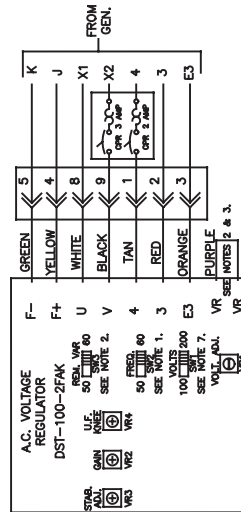
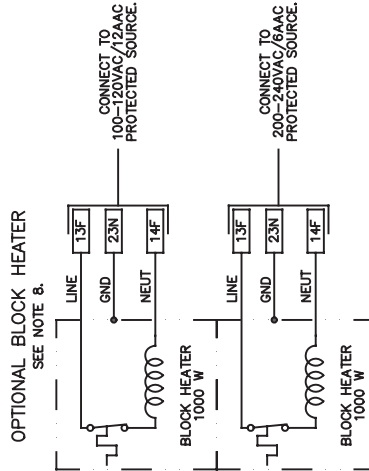
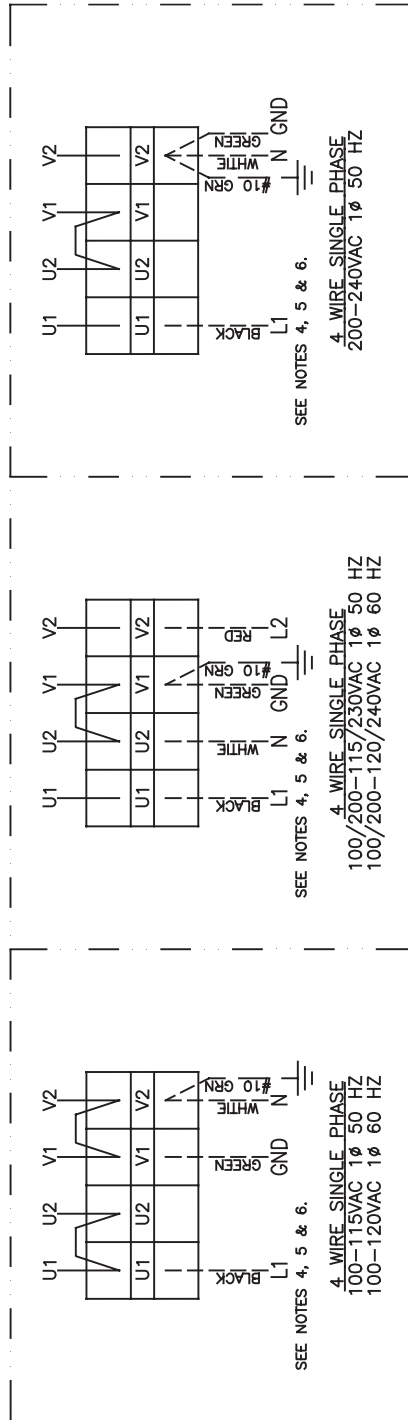

- NOTES:**
1. SET SW2 FOR CURRENT APPLICATION, (60 OR 60 HZ.)
  2. SET SW3 PER APPLICATION IF REMOTE VOLTAGE ADJUST RHEOSTAT IS USED.
  3. FOR REMOTE VOLTAGE ADJUST RHEOSTAT CUT JUMPER AND SPLICE INTO PURPLE LEADS.
  4. TERMINAL BLOCKS WILL NOT ACCOMMODATE LARGER GAUGE CONDUCTORS. IF REQUIRED, REMOVE AFFECTED LEADS FROM TERMINAL BLOCK(S) AND MAKE CONNECTIONS USING BOLT, LOCK WASHER AND NUT. ISOLATE BY WRAPPING WITH ELECTRICAL TAPE.
  5. MARINE GENSETS ARE GROUNDED BY CUSTOMER, AT CUSTOMER'S DISCRETION. INDUSTRIAL GENSETS ARE TO BE GROUNDED IN ACCORDANCE WITH THE NATIONAL ELECTRICAL CODE AND ANY APPLICABLE LOCAL CODES.
  6. HIDDEN (DASHED) LINES INDICATE CUSTOMER SUPPLIED AND CONNECTED MAIN OUTPUT CONDUCTORS. SIZING TO BE DETERMINED PER INSTALLATION.
  7. AVR INPUT SENSING SWITCH SW1 IS TO BE SET TO THE 200V POSITION FOR ALL VOLTAGES EXCEPT 100-120VAC APPLICATIONS.
  8. DO NOT ENERGIZE HEATER WHEN UNIT IS IN OPERATION.

Northern Lights AC Wiring Diagram –  
Taiyo PX300K2 4 Lead Generator  
with DST-100-2FAK AVR  
Drawing B-9724E

# AC Wiring Diagram

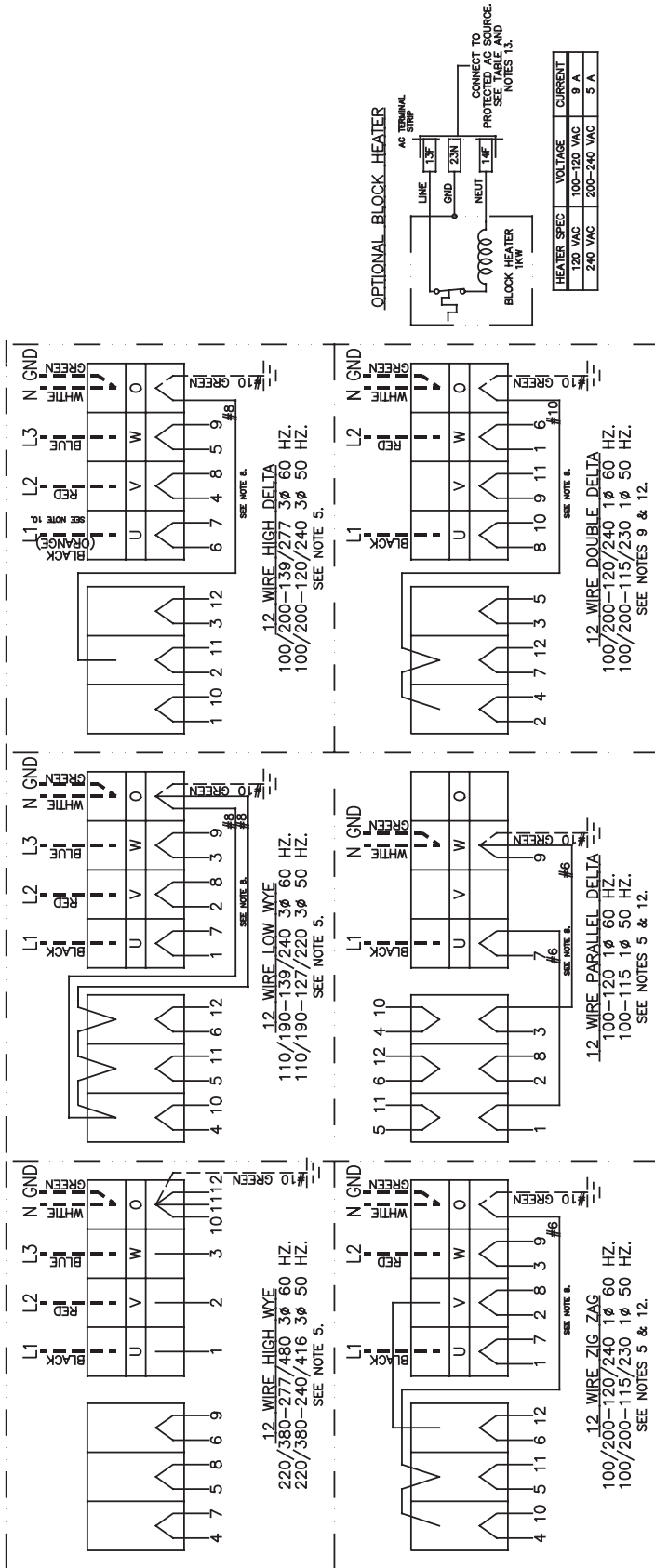

Northern Lights AC Wiring Diagram –  
 Taiyo PX300K2 12 Lead Generator  
 with DST-100-2FAK AVR  
 Drawing B-9723D

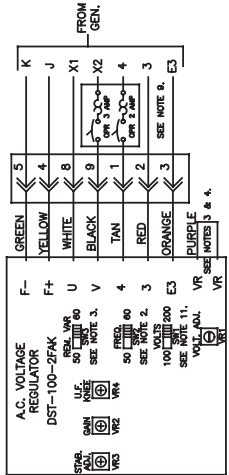

- NOTES:**
- ALL NEW INSTALLED CONDUCTORS ARE TO BE TYPE MTW, 105°C, STRANDED, 600VAC.
  - SET SW2 FOR CURRENT APPLICATION (50 OR 60 HZ).
  - SET SW3 PER APPLICATION IF REMOTE VOLTAGE ADJUST RHEOSTAT IS USED.
  - FOR REMOTE VOLTAGE ADJUST RHEOSTAT CUT JUMPER AND SPLICE INTO PURPLE LEADS.
  - DELETE NEUTRAL CONDUCTOR (AND JUMPER IF PRESENT), IF LOWER VOLTAGE IS NOT REQUIRED.
  - MARINE GENSETS ARE GROUNDED BY CUSTOMER, AT CUSTOMER'S DISCRETION. INDUSTRIAL GENSETS ARE TO BE GROUNDED IN ACCORDANCE WITH THE NATIONAL ELECTRICAL CODE AND ANY APPLICABLE LOCAL CODES.
  - NEUTRAL CONDUCTORS ARE TO BE INSTALLED IN ACCORDANCE WITH THE NATIONAL ELECTRICAL CODE AND ANY APPLICABLE LOCAL CODES.
  - NEUTRAL CONDUCTORS SIZED FOR 30KW UNITS AT THE LOWEST LISTED VOLTAGE. CONSULT N.L.I. ENGINEERING FOR CONDUCTOR SIZES AT OTHER GENSET VOLTAGE/AW RATINGS.
  - FOR THE DOUBLE DELTA CONFIGURATION THE AVR IS TO BE REMOVED AS FOLLOWS: DISCONNECT LEADS 3 AND 4 FROM AVR. CONNECT LEAD 3 TO AVR TERM. 4 (THROUGH C.B.), CONNECT LEAD 4 TO AVR TERM. 3. DISCONNECT LEADS 5, 6 FROM AVR AND ISOLATE. CONNECT AVR TERMINAL E3 TO MAIN OUTPUT BLOCK TERM. 3. DISCONNECT LEAD E3 FROM AVR AND ISOLATE. CONNECT AVR TERMINAL E3 TO MAIN OUTPUT BLOCK TERM. 3. DISCONNECT LEAD E3 FROM AVR AND ISOLATE. CONNECT AVR TERMINAL E3 TO MAIN OUTPUT BLOCK TERM. 3.
  - LINE ONE (HIGH LEG) TO BE MARKED ORANGE WHEN NEUTRAL IS PRESENT, IN ACCORDANCE WITH ARTICLE 215-8 OF THE NATIONAL ELECTRICAL CODE.
  - AVR INPUT SENSING SWITCH SW1 IS TO BE SET TO THE 200V POSITION FOR ALL VOLTAGES EXCEPT 100-120VAC APPLICATIONS.
  - THE AVR IS TO BE USED FOR MODEL M300SERV ONLY.
  - DO NOT ENERGIZE HEATER WHEN UNIT IS IN OPERATION.

# DC Wiring Diagram

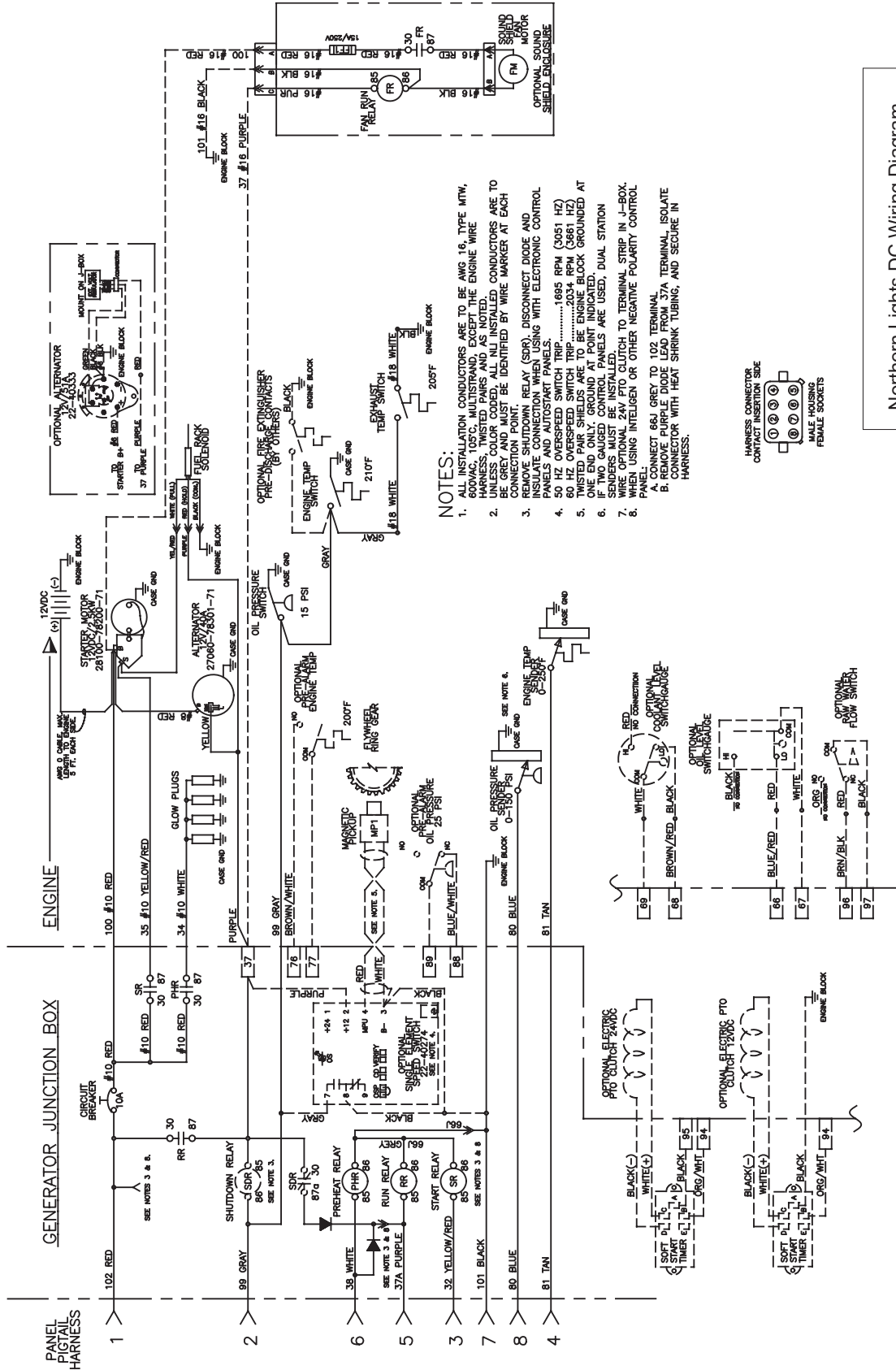

- NOTES:**
1. ALL INSTALLATION CONDUCTORS ARE TO BE AWG 16, TYPE MTW, 600VAC, 105°C, MULTISTRAND, EXCEPT THE ENGINE WIRE HARNESS, TWISTED PAIRS AND AS NOTED.
  2. ALL CONDUCTORS MUST BE IDENTIFIED BY WIRE MARKER AT EACH CONNECTION POINT.
  3. REMOVE SHUTDOWN RELAY (SDR), DISCONNECT DIODE AND PANELS AND AUTOSTART PANELS.
  4. 50 HZ OVERSPEED SWITCH TYPE.....1695 RPM (3051 Hz) 50 HZ OVERSPEED SWITCH TYPE.....1095 RPM (3651 Hz)
  5. TWISTED PAIR SHIELDS ARE TO BE ENGINE BLOCK GROUNDED AT ONE END ONLY. GROUND AT POINT INDICATED.
  6. IF TWO GAUGED CONTROL PANELS ARE USED, DUAL STATION SENDERS MUST BE INSTALLED.
  7. WHEN USING INTELLIGEN OR OTHER NEGATIVE POLARITY CONTROL PANEL:
  8. PANEL:
    - A. CONNECT 66J GREY TO 102 TERMINAL
    - B. REMOVE PURPLE DIODE LEAD FROM 37A TERMINAL, ISOLATE AND REMOVE PURPLE LEAD FROM 37A TERMINAL, SHINK TUBING, AND SECURE IN HARNESS.

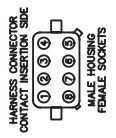

Northern Lights DC Wiring Diagram –  
M864W/M864W3 12 VDC  
Standard Ground B+ Control  
Drawing B-10770C

# DC Wiring Diagram

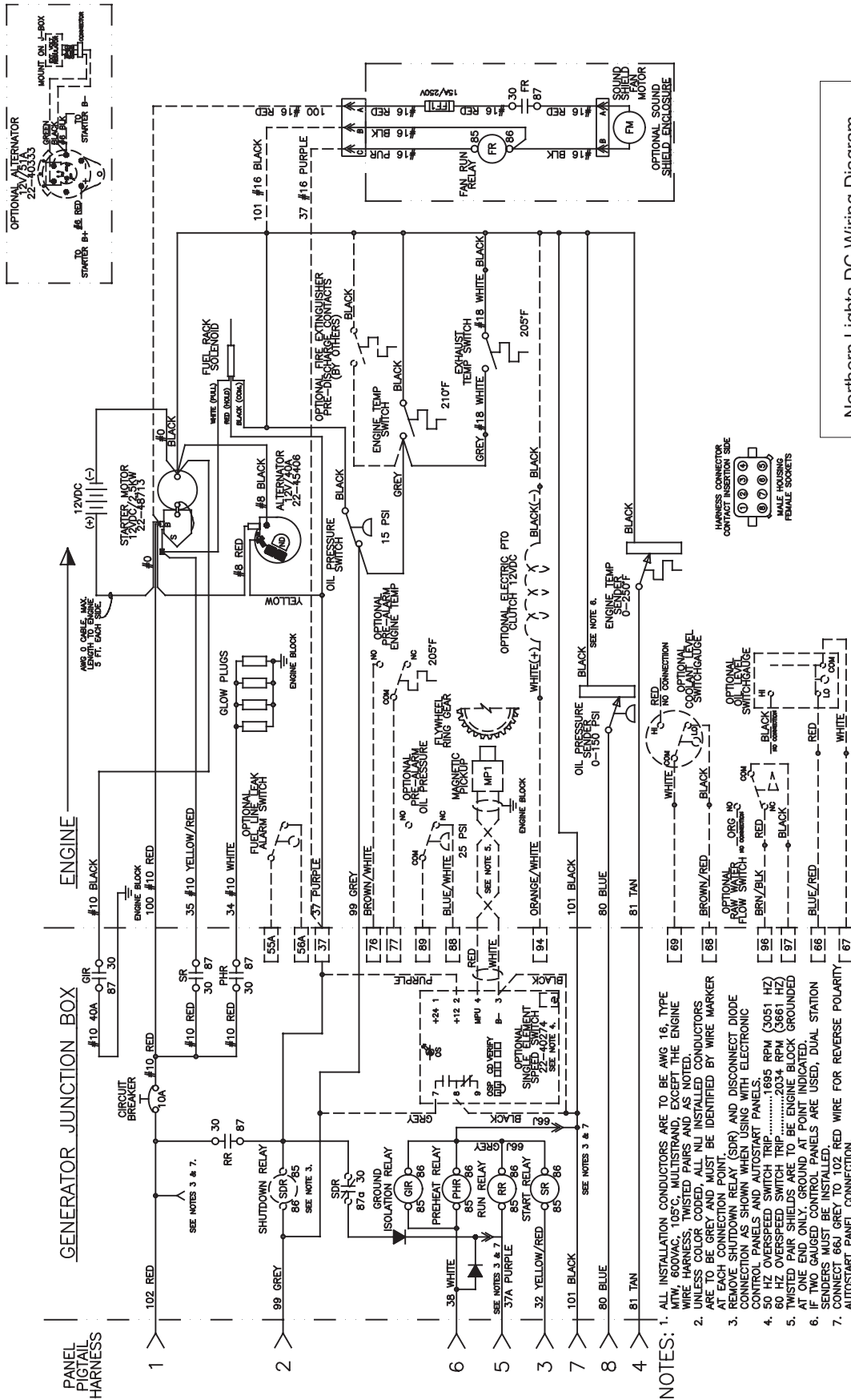

Northern Lights DC Wiring Diagram –  
M864W/M864W3 12 VDC  
Isolated Ground B+ Control  
Drawing B-10844

- NOTES:**
1. ALL INSTALLATION CONDUCTORS ARE TO BE AWG 16 TYPE MTW, 60VAC, 105°C, MULTISTRAND, EXCEPT THE ENGINE WIRE HARNESS, TWISTED PAIRS AND AS NOTED, UNLESS COLOR CODED, ALL ALL INSTALLED CONDUCTORS ARE TO BE GREY AND MUST BE IDENTIFIED BY WIRE MARKER AT EACH CONNECTION POINT.
  2. REMOVE SHUTDOWN RELAY (SDR) AND DISCONNECT DIODE CONNECTION AS SHOWN WHEN USING WITH ELECTRONIC CONTROL PANELS AND AUTOSTART PANELS.
  3. 60 RPM OVERSPEED SWITCH TRIP.....2030 RPM (3661 Hz)
  4. 80 RPM OVERSPEED SWITCH TRIP.....2030 RPM (3661 Hz)
  5. TWISTED PAIR SHIELDS ARE TO BE ENGINE BLOCK GROUNDED AT ONE END ONLY, GROUND AT POINT INDICATED.
  6. IF TWO GAUGED CONTROL PANELS ARE USED, DUAL STATION SENDERS MUST BE INSTALLED.
  7. CONNECT 66J GREY TO 102 RED WIRE FOR REVERSE POLARITY. AUTOSTART PANEL CONNECTION.



# DC Wiring Diagram

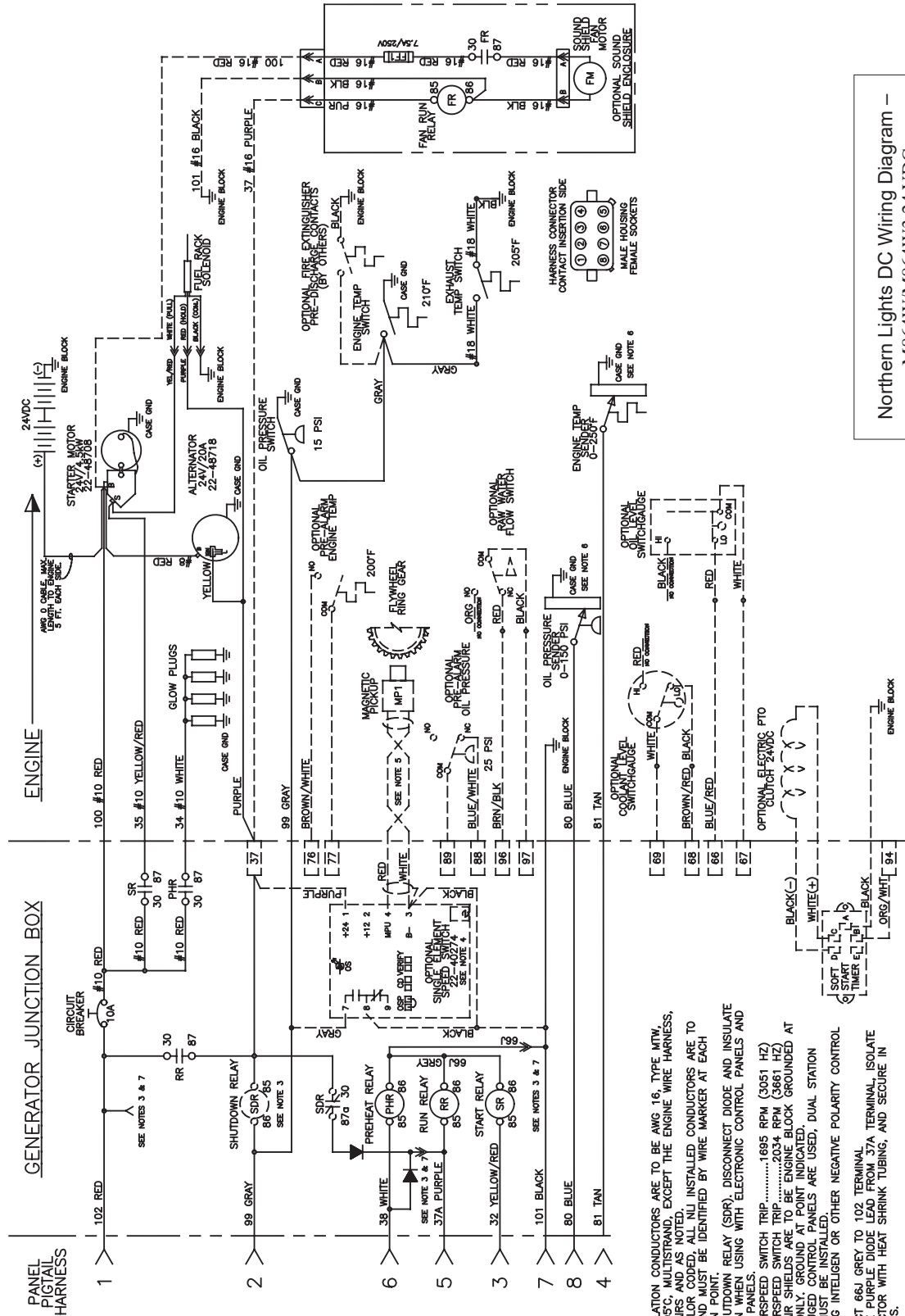

Northern Lights DC Wiring Diagram –  
M864W/M864W3 24 VDC  
Standard Ground B+ Control  
Drawing B-10818F

- NOTES:**
1. ALL INSTALLATION CONDUCTORS ARE TO BE AWG 16, TYPE MTW, 600VAC, 105°C, MULTISTRAND, EXCEPT THE ENGINE WIRE HARNESS, TWISTED PAIRS AND AS NOTED.
  2. UNLESS COLOR CODED, ALL NLI INSTALLED CONDUCTORS ARE TO BE GREY AND MUST BE IDENTIFIED BY WIRE MARKER AT EACH CONNECTION POINT.
  3. REMOVE SHUTDOWN RELAY (SDR), DISCONNECT DIODE AND INSULATE AUTOSTART PANELS.
  4. 50 HZ OVERSPEED SWITCH TRIP .....1695 RPM (3051 HZ)  
80 HZ OVERSPEED SWITCH TRIP .....2034 RPM (3661 HZ)
  5. TWISTED PAIR SHIELDS ARE TO BE ENGINE BLOCK GROUNDED AT ONE END ONLY. GROUND AT POINT INDICATED.
  6. IF TWO GAUGED CONTROL PANELS ARE USED, DUAL STATION SENDERS MUST BE INSTALLED.
  7. WHEN USING INTELI GEN OR OTHER NEGATIVE POLARITY CONTROL PANEL:  
A. CONNECT 66A GREY TO 102 TERMINAL.  
B. CONNECT PURPLE DIODE AND 100A/7A TERMINAL ISOLATE CONNECTOR WITH HEAT SHRINK TUBING, AND SECURE IN HARNESS.

# DC Wiring Diagram

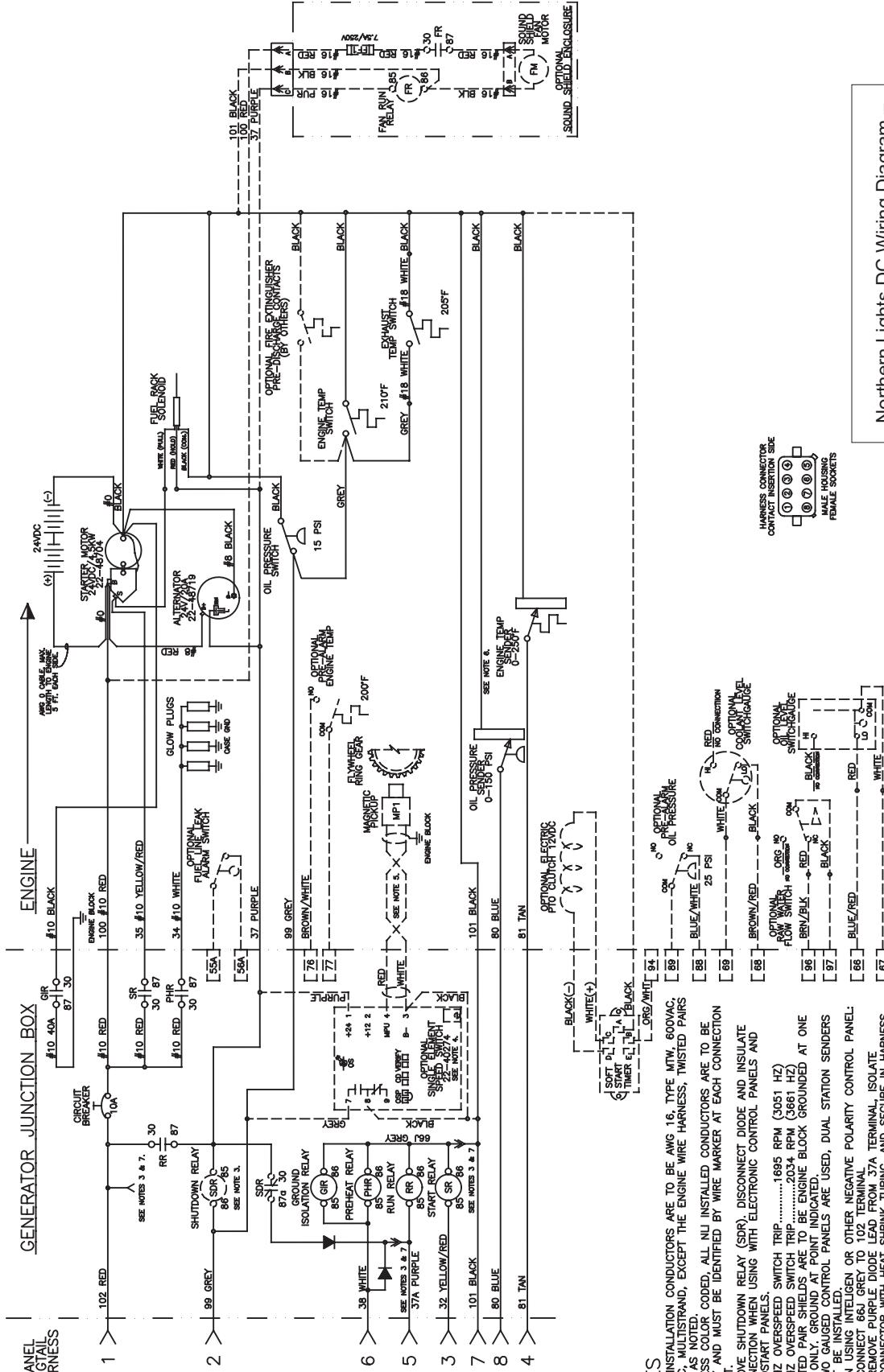

## NOTES

1. ALL INSTALLATION CONDUCTORS ARE TO BE AWG 16, TYPE MTW, 600VAC, 105°C, MULTISTRAND, EXCEPT THE ENGINE WIRE HARNESS, TWISTED PAIRS, AND AS NOTED.
2. UNLESS COLOR CODED, ALL NI INSTALLED CONDUCTORS ARE TO BE GREY, AND MUST BE IDENTIFIED BY WIRE MARKER AT EACH CONNECTION POINT.
3. REMOVE SHUTDOWN RELAY (SDR), DISCONNECT DIODE AND INSULATE CONNECTION WHEN USING WITH ELECTRONIC CONTROL PANELS AND AUTOSTART PANELS.
4. 50 HZ OVERSPEED SWITCH TRIP .....1695 RPM (3051 HZ)  
60 HZ OVERSPEED SWITCH TRIP .....2034 RPM (3661 HZ)
5. TWISTED PAIR SHIELDS ARE TO BE ENGINE BLOCK GROUNDED AT ONE END ONLY. GROUND AT POINT INDICATED.
6. IF TWO GAUGED CONTROL PANELS ARE USED, DUAL STATION SENDERS MUST BE INSTALLED.
7. WHEN USING INTELLIGEN OR OTHER NEGATIVE POLARITY CONTROL PANEL:  
A. CONNECT 66J GREY TO 102 TERMINAL.  
B. REMOVE PURPLE DIODE LEAD FROM 37A TERMINAL. ISOLATE CONNECTOR WITH HEAT SHRINK TUBING, AND SECURE IN HARNESS.

Northern Lights DC Wiring Diagram –  
M864W/M864W3 24 VDC  
Isolated Ground B+ Control  
Drawing B-10843

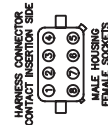

# DC Wiring Diagram

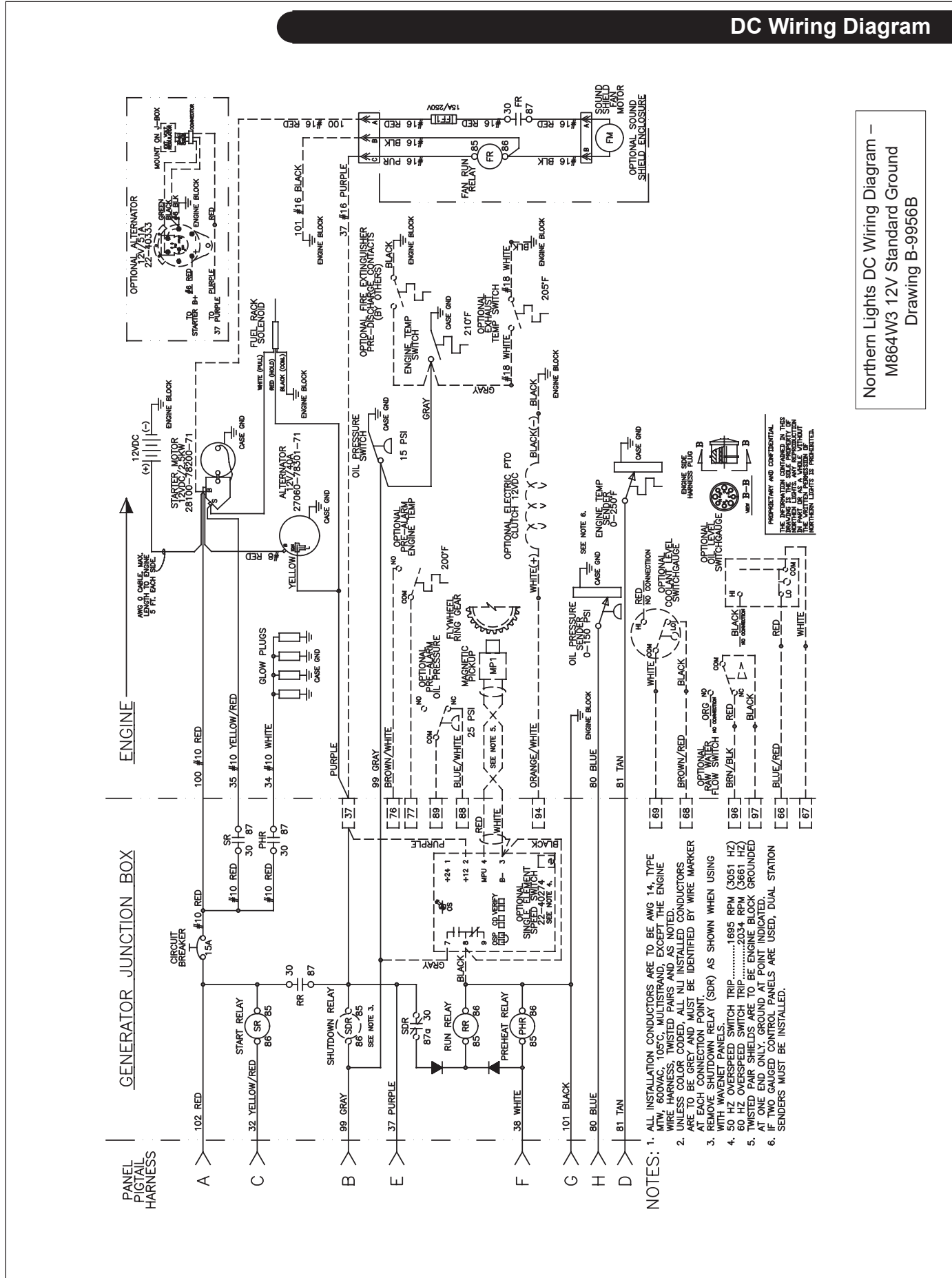

Northern Lights DC Wiring Diagram –  
M864W3 12V Standard Ground  
Drawing B-9956B

- NOTES:**
1. ALL INSTALLATION CONDUCTORS ARE TO BE AWG 14, TYPE MTW, 600VAC, 105°C, MULTISTRAND, EXCEPT THE ENGINE WIRE HARNESS, TWISTED PAIRS AND AS NOTED.
  2. UNLESS COLOR CODED, ALL NLI INSTALLED CONDUCTORS ARE TO BE GREY AND MUST BE IDENTIFIED BY WIRE MARKER.
  3. RELAY CONNECTION POINTS (SDR) AS SHOWN WHEN USING WITH WAVENET PANELS.
  4. 50 HZ OVERSPEED SWITCH TRIP .....1695 RPM (3051 HZ)
  5. 60 HZ OVERSPEED SWITCH TRIP .....2034 RPM (3661 HZ)
  6. TWISTED PAIR SHIELDS ARE TO BE ENGINE BLOCK GROUNDED AT ONE END ONLY. GROUND AT POINT INDICATED.
  7. IF TWO GAUGED CONTROL PANELS ARE USED, DUAL STATION SENDERS MUST BE INSTALLED.

PROPRIETARY AND CONFIDENTIAL  
THE INFORMATION CONTAINED IN THIS DRAWING IS THE PROPERTY OF NORTHERN LIGHTS. ANY REPRODUCTION OR TRANSMISSION OF THIS INFORMATION WITHOUT THE WRITTEN PERMISSION OF NORTHERN LIGHTS IS PROHIBITED.

# DC Wiring Diagram

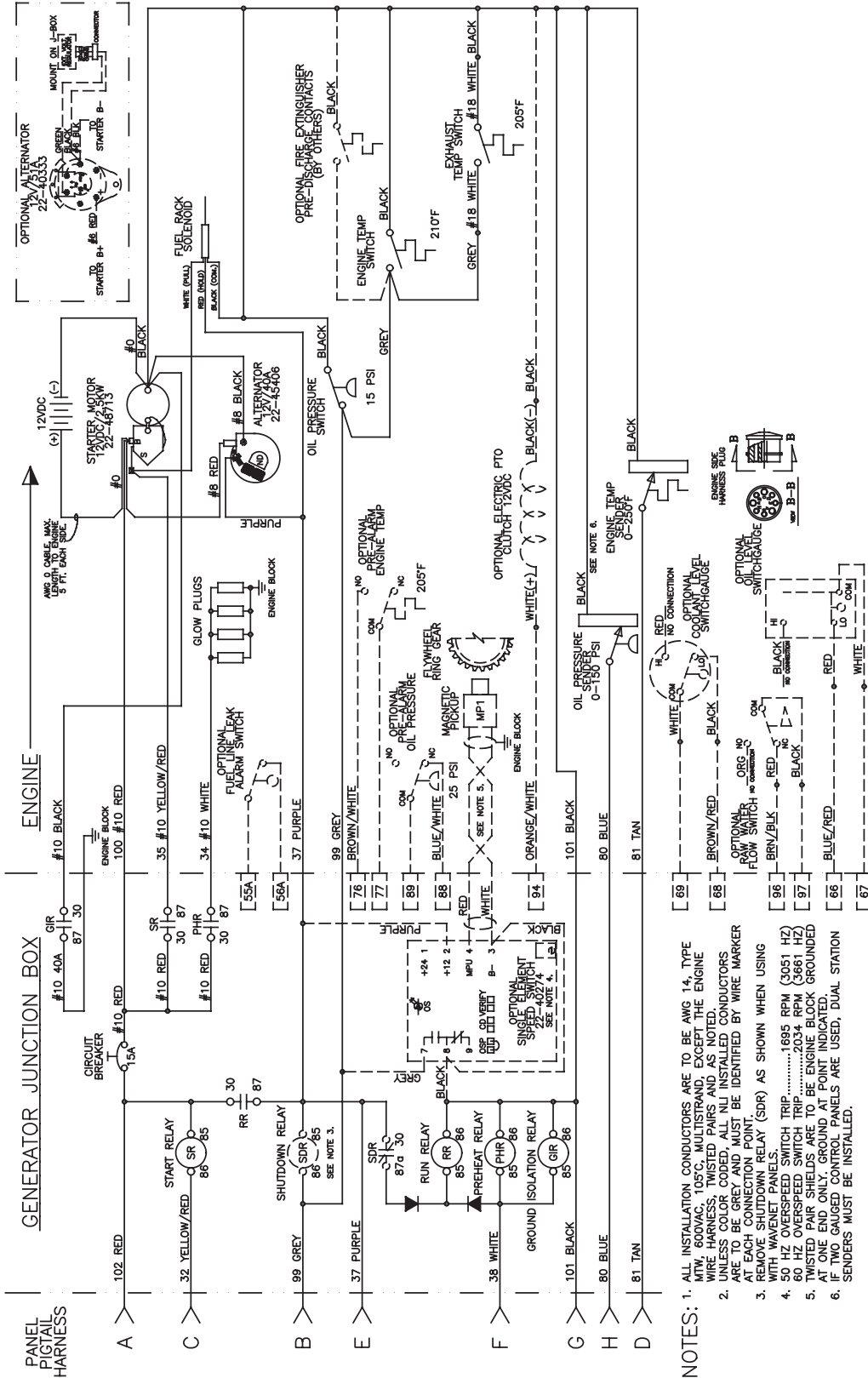

- NOTES:**
1. ALL INSTALLATION CONDUCTORS ARE TO BE AWG 14, TYPE WTY, 600VAC, 105°C, MULTISTRAND, EXCEPT THE ENGINE WIRING. RED WIRE PAIRS ARE TO BE INSTALLED AS TWISTED PAIRS UNLESS OTHERWISE SPECIFIED. ALL INSTALLED CONDUCTORS ARE TO BE GREY AND MUST BE IDENTIFIED BY WIRE MARKER AT EACH CONNECTION POINT.
  2. REMOVE SHUTDOWN RELAY (SDR) AS SHOWN WHEN USING WITH WAVENET PANELS.
  3. 50 HZ OVERSPEED SWITCH TRIP .....1895 RPM (3051 HZ)
  4. 60 HZ OVERSPEED SWITCH TRIP .....2034 RPM (3661 HZ)
  5. TWISTED PAIR SHIELDS ARE TO BE ENGINE BLOCK GROUNDED AT ONE END ONLY. GROUND AT POINT INDICATED.
  6. IF TWO GAUGED CONTROL PANELS ARE USED, DUAL STATION SENDERS MUST BE INSTALLED.

Northern Lights DC Wiring Diagram –  
M864W 12V Isolated Ground  
Drawing B-9969

# DC Wiring Diagram

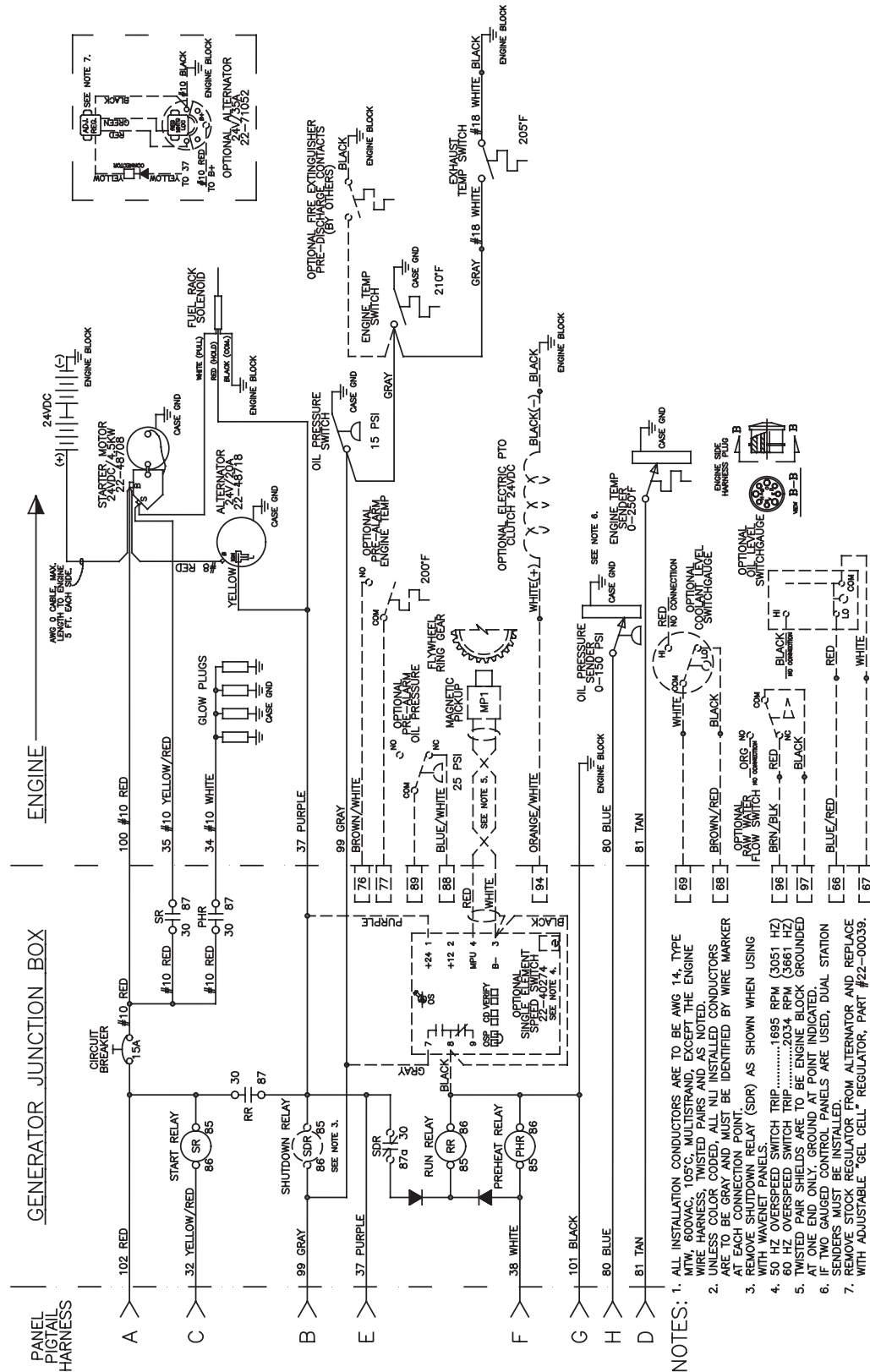

- NOTES:**
1. ALL INSTALLATION CONDUCTORS ARE TO BE AWG 14, TYPE MTW, 600VAC, 105°C, MULTISTRAND, EXCEPT THE ENGINE WIRE HARNESS, TWISTED PAIRS AND AS NOTED CONDUCTORS.
  2. WIRE PAIRS: ALL WIRE PAIRS AND AS NOTED CONDUCTORS ARE TO BE GRAY AND MUST BE IDENTIFIED BY WIRE MARKER AT EACH CONNECTION POINT.
  3. REMOVE SHUTDOWN RELAY (SDR) AS SHOWN WHEN USING WITH WAVENET PANELS.
  4. 50 HZ OVERSPEED SWITCH TRIP .....1695 RPM (3051 HZ)
  5. 60 HZ OVERSPEED SWITCH TRIP .....2034 RPM (3661 HZ)
  6. TWISTED PAIR SHIELDS ARE TO BE ENGINE BLOCK GROUNDED AT ONE END ONLY. GROUND AT POINT INDICATED.
  7. IF TWO GAUGED CONTROL PANELS ARE USED, DUAL STATION SENDERS MUST BE INSTALLED. REMOVE STOCK REGULATOR FROM ALTERNATOR AND REPLACE WITH ADJUSTABLE 'GEL CELL' REGULATOR, PART #22-00039.

Northern Lights DC Wiring Diagram –  
M864W3 24V Standard Ground  
Drawing B-9878D

# DC Wiring Diagram

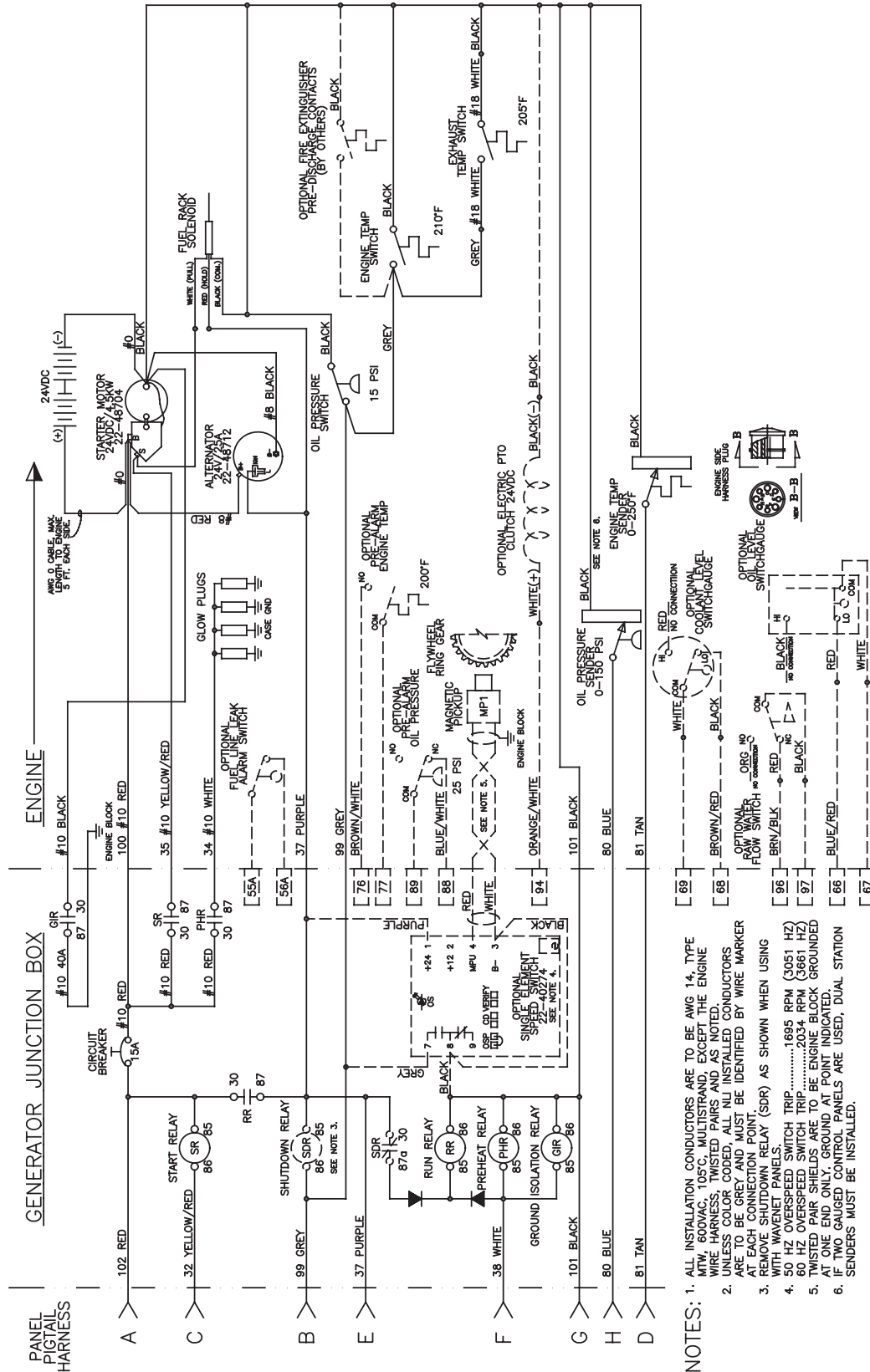

- NOTES:**
1. ALL INSTALLATION CONDUCTORS ARE TO BE AWG 14, TYPE MTW, 600VAC, 105°C, MULTISTRAND, EXCEPT THE ENGINE WIRE HARNESS, TWISTED PAIRS AND AS NOTED. UNLESS COLOR CODED, ALL NLI INSTALLED CONDUCTORS ARE TO BE GREY AND MUST BE IDENTIFIED BY WIRE MARKER AT EACH CONNECTION POINT.
  2. REMOVE SHUTDOWN RELAY (SDR) AS SHOWN WHEN USING WITH 770 OVERSPEED SWITCH TRIP ..... 1695 RPM (3051 HZ) 60 HZ OVERSPEED SWITCH TRIP ..... 2034 RPM (3661 HZ)
  3. TWISTED PAIR SHIELDS ARE TO BE ENGINE BLOCK GROUNDED AT ONE END ONLY. GROUND AT POINT INDICATED.
  4. IF TWO GAUGED CONTROL PANELS ARE USED, DUAL STATION SENDERS MUST BE INSTALLED.

Northern Lights DC Wiring Diagram –  
M864W 24V Isolated Ground  
Drawing B-9901D

CONTROL PANEL – B+ CONTROL

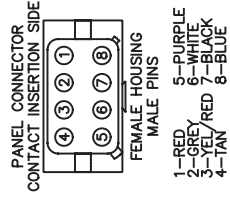
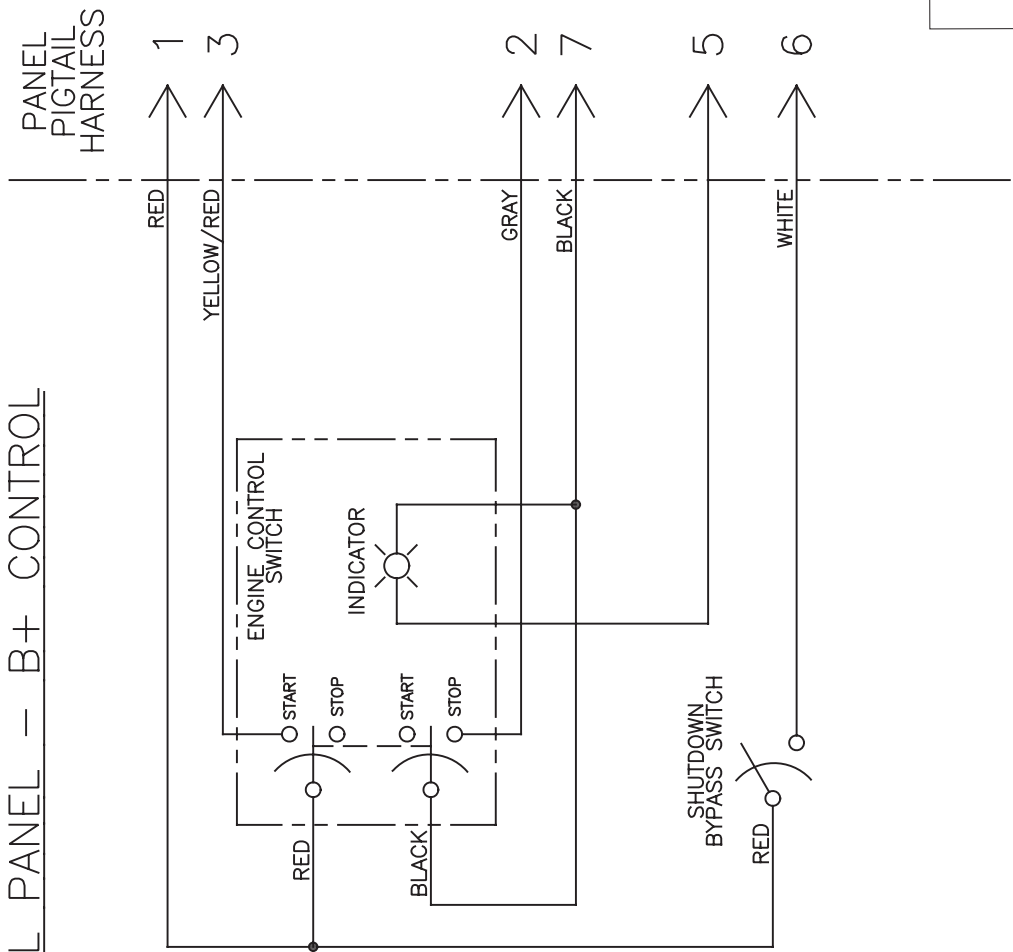

**Panel Wiring Diagram**  
S-1 Panel, B+ Deutsch  
A-12798

# Wiring Diagrams

## CONTROL PANEL - B+ CONTROL

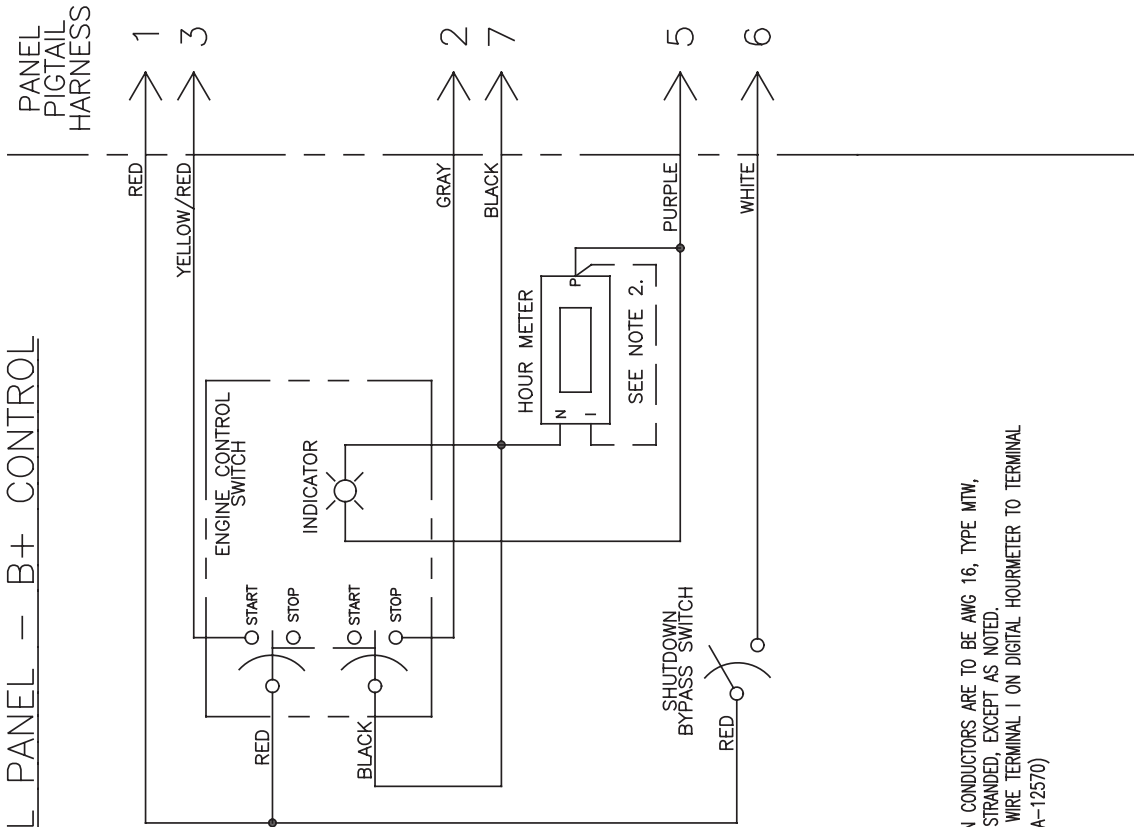

P/N	12/24v
22-95605	MTU
22-95910	DIGITAL HOURMETER
22-95603	

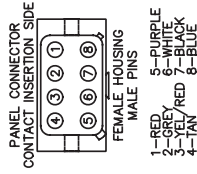

### NOTES:

1. ALL INSTALLATION CONDUCTORS ARE TO BE AWG 16, TYPE MTW, 600VAC, 105°C, STRANDED, EXCEPT AS NOTED.
2. FOR 22-95603, WIRE TERMINAL 1 ON DIGITAL HOURMETER TO TERMINAL P. (REFERENCE A-12570)

**Panel Wiring Diagram**  
S-1B Panel, B+  
A-12791B



CONTROL PANEL - B+ CONTROL

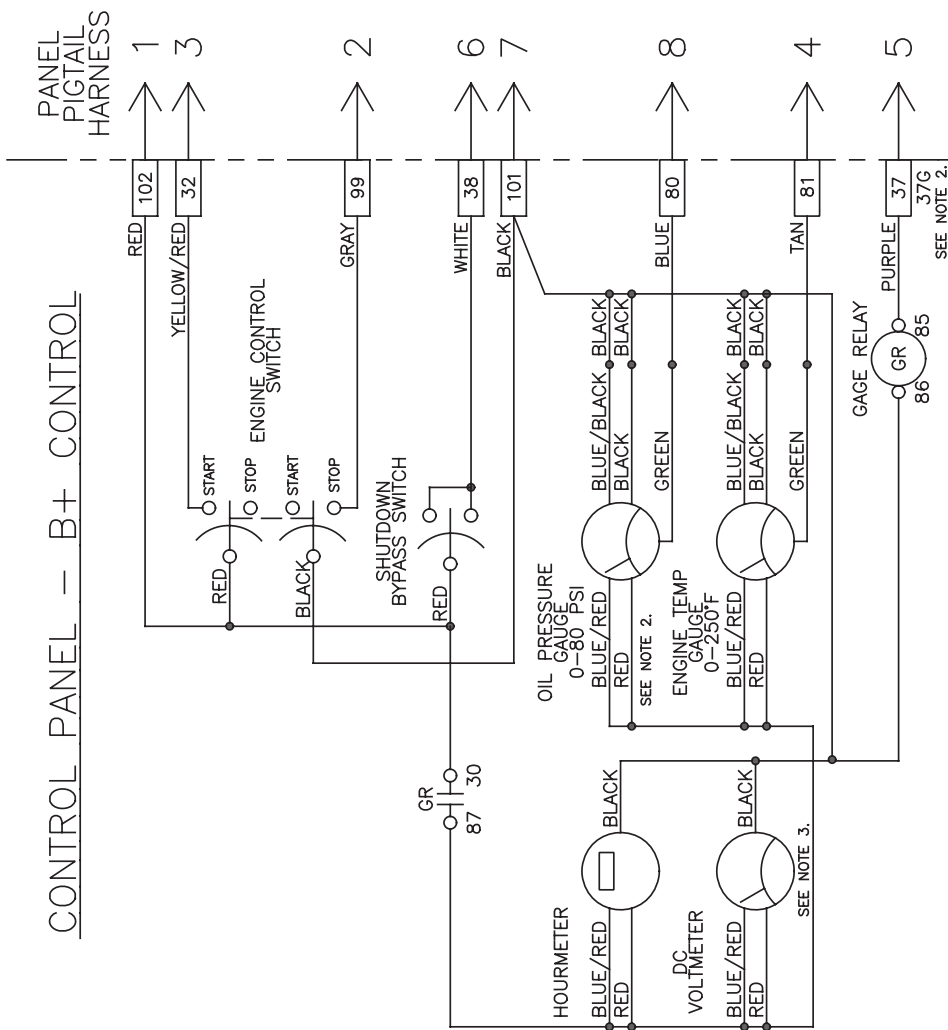

	P/N'S
12V	22-95601
24V	22-95602
864 12V	22-98717
864 24V	22-98718
JCG 24V	22-95657

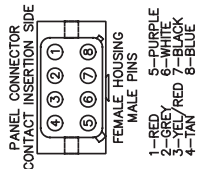

**Panel Wiring Diagram**  
S-3B Panel, Viewline B+  
A-12799A

**NOTES:**

1. OIL PRESSURE GAUGE IS TO BE 0-150 PSI ON PANELS 22-98717 & 22-98718.
2. RELABEL TERMINAL 37 TO 37G WHEN LIGHTING FUSE IS USED. REFER TO DC WIRING DIAGRAM.
3. FOR 22-95657 WITH NO HOURMETER, SECURE EXTRA HARNESS WIRES AND INSTALL A 12 TERMINAL STRIP WITH 4 UNMARKED TERMINALS.

# Wiring Diagrams

## CONTROL PANEL - B+ CONTROL

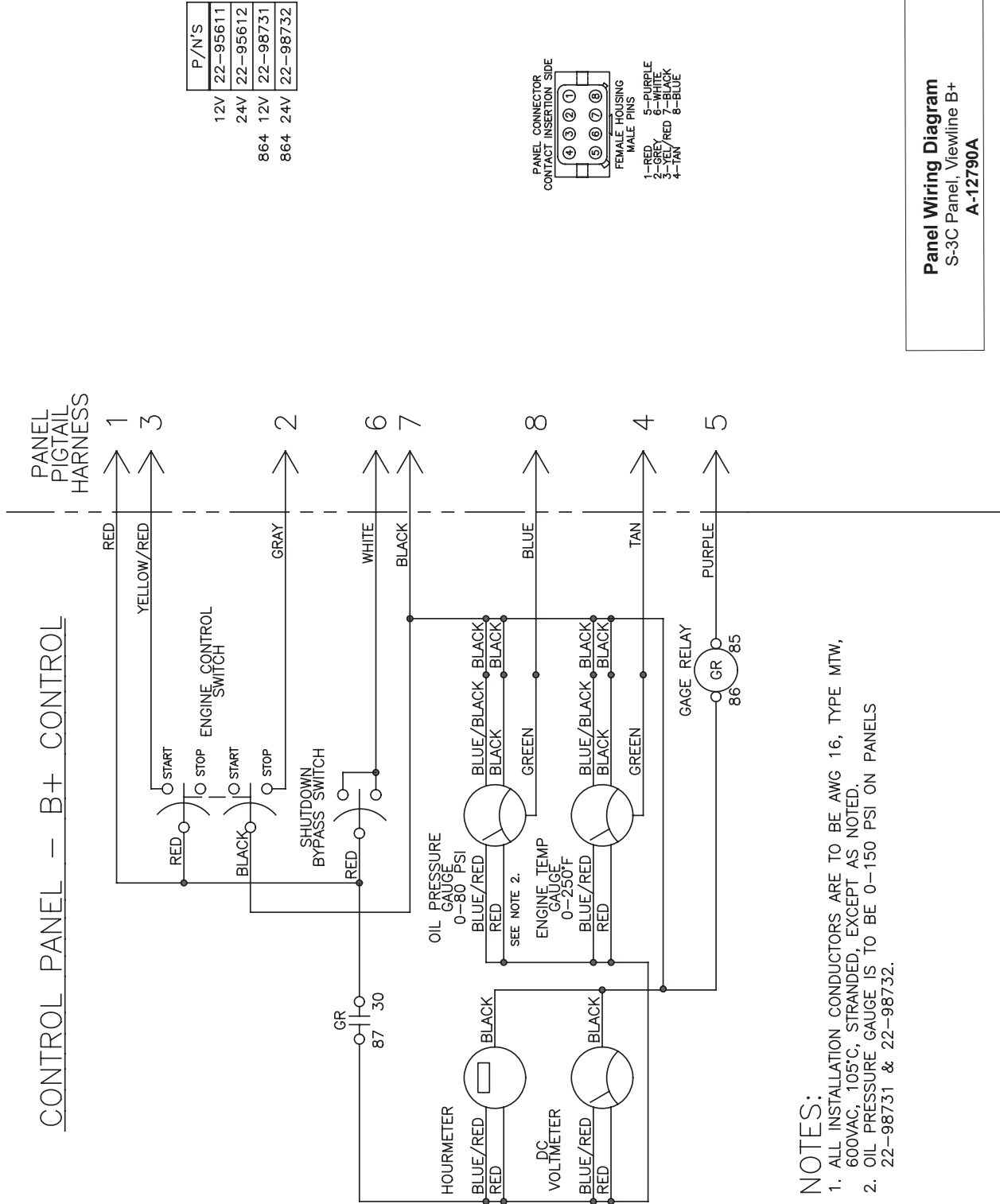

### NOTES:

1. ALL INSTALLATION CONDUCTORS ARE TO BE AWG 16, TYPE MTW, 600VAC, 105°C, STRANDED, EXCEPT AS NOTED.
2. OIL PRESSURE GAUGE IS TO BE 0-150 PSI ON PANELS 22-98731 & 22-98732.

**Panel Wiring Diagram**  
S-3C Panel, Viewline B+  
A-12790A

# Wiring Diagrams

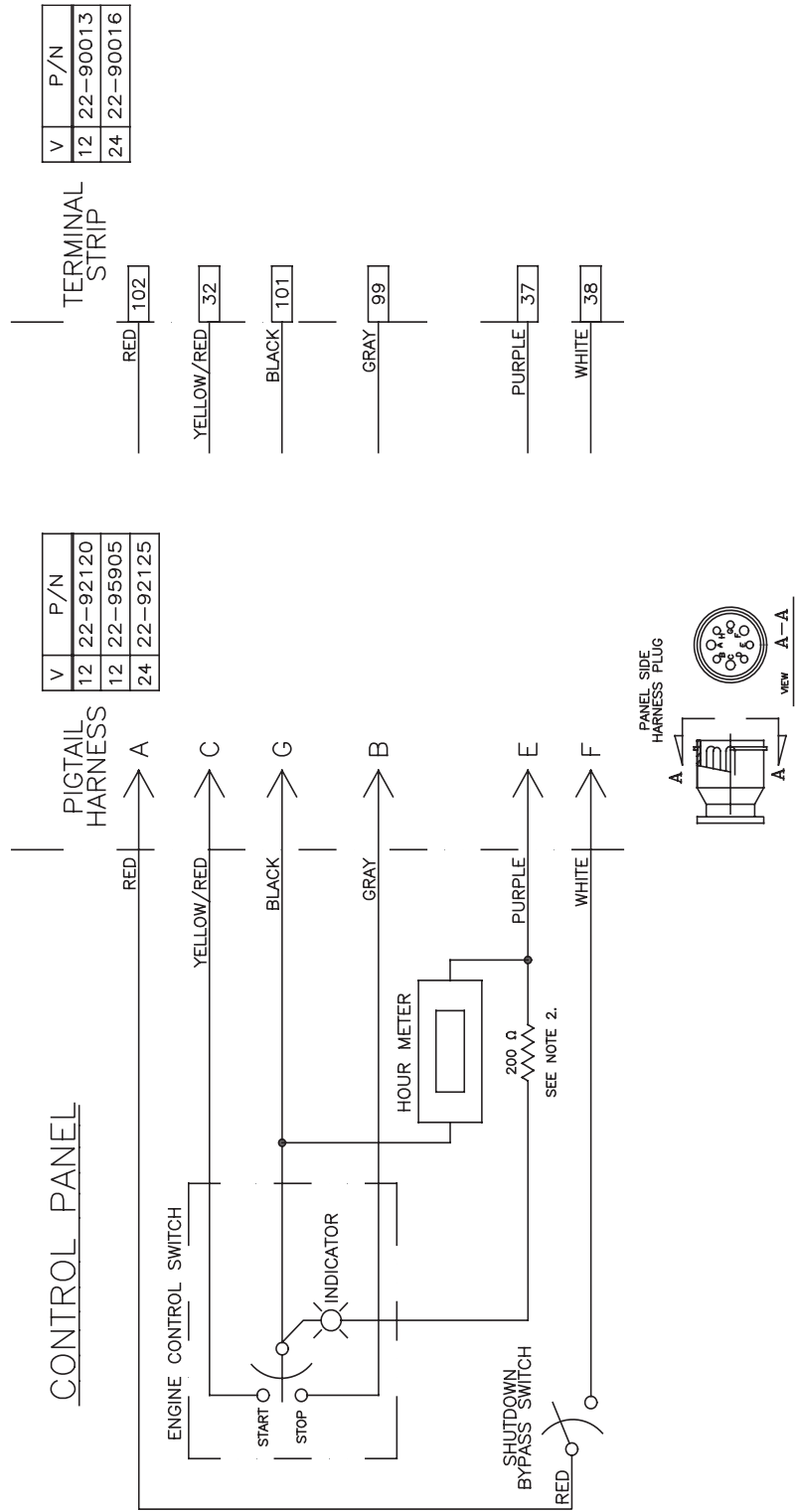

**Panel Wiring Diagram**  
S-1B Control Panel  
Drawing A-12667A

- NOTES:**
1. ALL INSTALLATION CONDUCTORS ARE TO BE AWG 14, TYPE MTW, 600VAC, 105°C, STRANDED, EXCEPT AS NOTED.
  2. RESISTOR USED ON 24V UNITS ONLY.
  3. COMBINES AND REPLACES DRAWINGS A-3170, A-4792, A-6650, AND A-4134.

# Wiring Diagrams

## CONTROL PANEL

PANEL  
PIGTAIL  
HARNESS

P/N'S
22-96846
22-96856
22-99501
22-99511

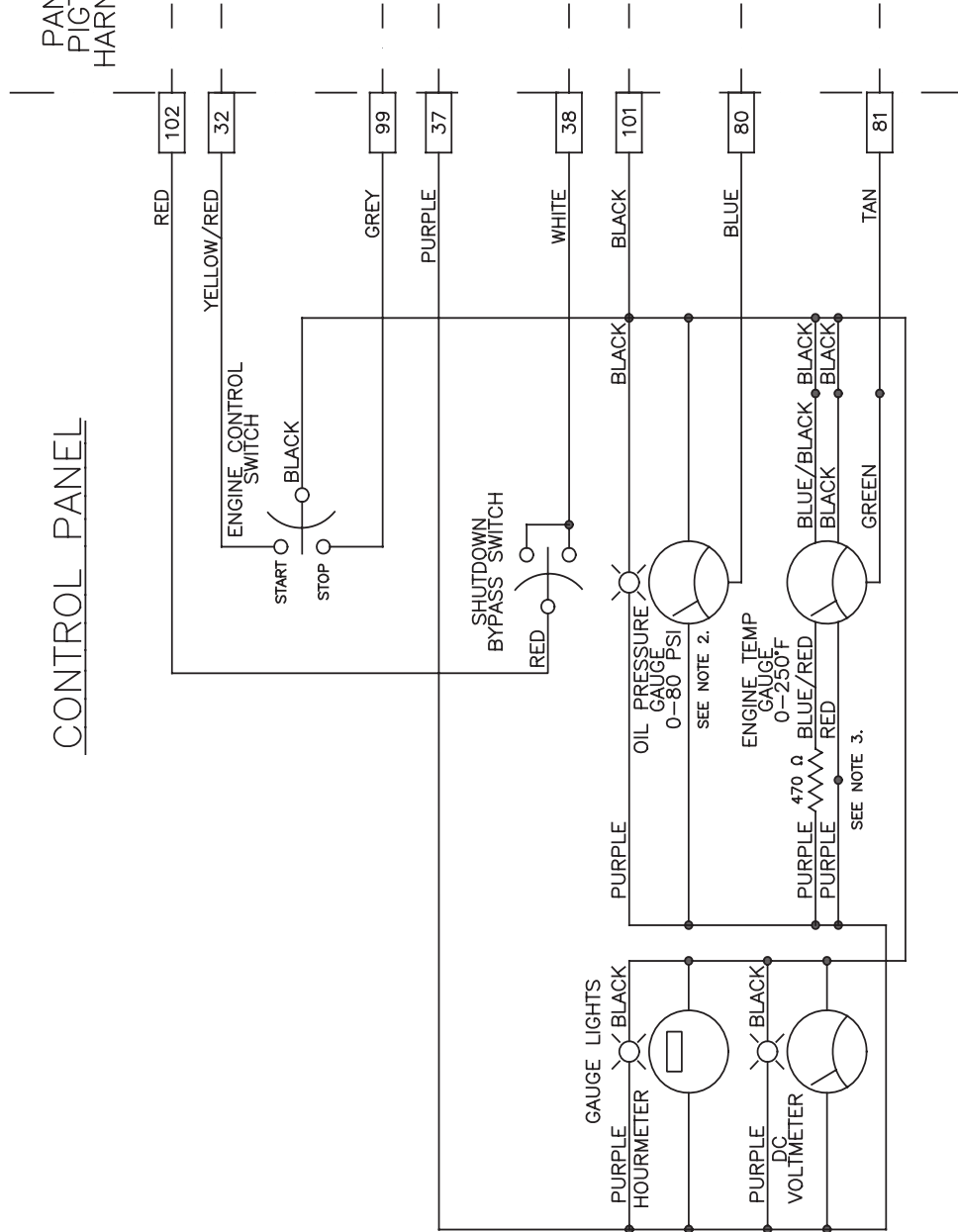

### NOTES:

1. ALL INSTALLATION CONDUCTORS ARE TO BE AWG 14, TYPE MTW, 600VAC, 105°C, STRANDED, EXCEPT AS NOTED.
2. OIL PRESSURE GAUGE IS TO BE 0-150 PSI ON PANELS 22-96846 & 22-96856.
3. RESISTOR IS TO BE 470 OHMS, 5% 1/4W OR FROM RESISTOR KIT 22-40611.

**Panel Wiring Diagram**  
S-3B / S-3C Oceanline / Viewline Panels 12V  
**A-12574A**

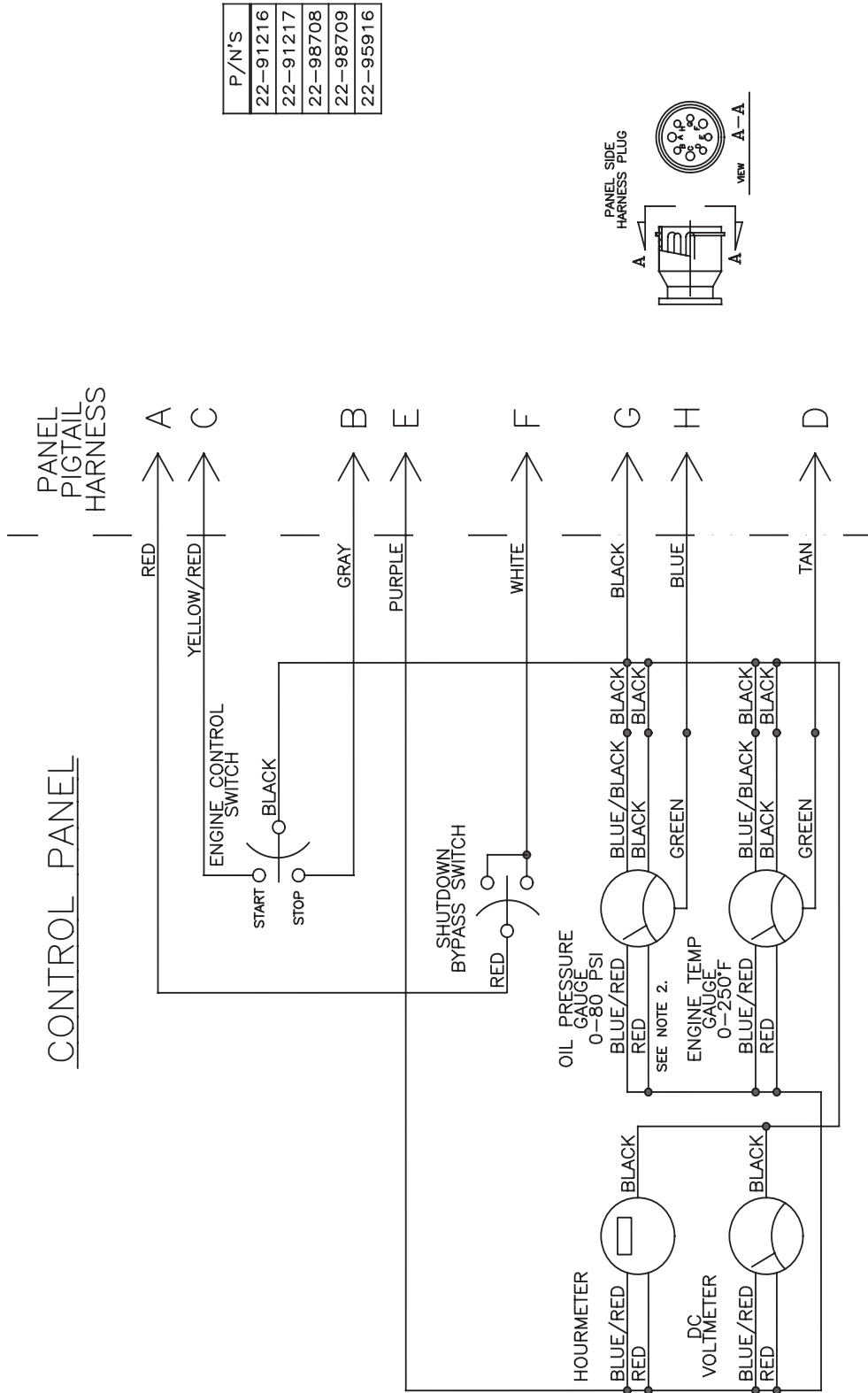

P/N'S
22-91216
22-91217
22-98708
22-98709
22-95916

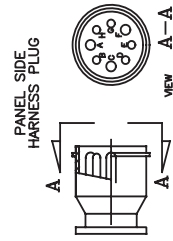

**Panel Wiring Diagram**  
S-3C control Panel, Viewline  
A-12645B

- NOTES:**
1. ALL INSTALLATION CONDUCTORS ARE TO BE AWG 14, TYPE MTW, 600VAC, 105°C, STRANDED, EXCEPT AS NOTED.
  2. OIL PRESSURE GAUGE IS TO BE 0-150 PSI ON PANELS 22-98708 & 22-98709.



4420 14th Ave. NW., Seattle WA 98107

Tel: (206) 789-3880 • 1-800-762-0165 • Fax: (206) 782-5455

Northern Lights and Lugger are registered trademarks of Northern Lights, Inc.

© 2017 All rights reserved. Litho USA.