

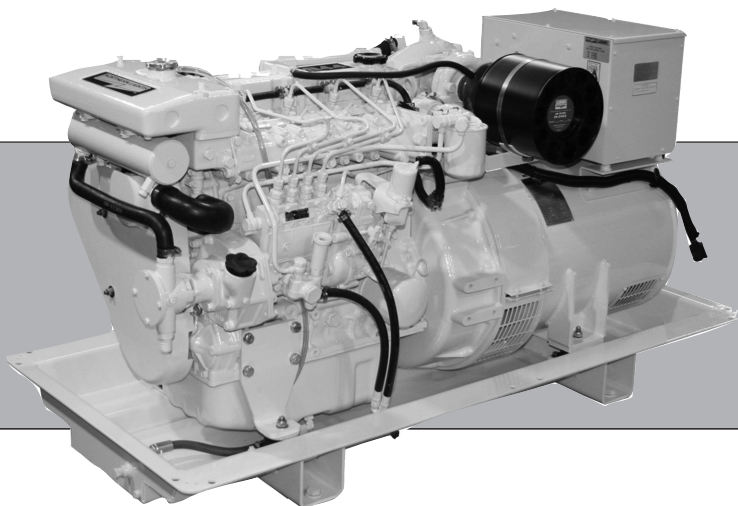

# OPERATOR'S MANUAL

## OM944T3

For Models: M944T3 and M40C3



[www.northern-lights.com](http://www.northern-lights.com)



— CALIFORNIA —  
Proposition 65 Warning:

**Breathing Diesel engine exhaust and some of its constituents are known to the State of California to cause cancer, birth defects, and other reproductive harm.**

- \* Always start and operate the engine in a well-ventilated area.
- \* If in an enclosed area, vent the exhaust to the outside.
- \* Do not modify or tamper with the exhaust system.
- \* Do not idle the engine except as necessary.

**For more information, go to [www.P65warnings.ca.gov/diesel](http://www.P65warnings.ca.gov/diesel).**

**Northern Lights**

4420 14th Avenue NW  
Seattle, WA 98107  
Tel: (206) 789-3880  
Fax: (206) 782-5455

Copyright ©2018 Northern Lights, Inc.  
All rights reserved. Northern Lights™, and  
the Northern Lights logo are trademarks of  
Northern Lights, Inc.

Printed in U.S.A.  
PART NO.: OM944T3 2/20



# OPERATOR'S MANUAL

for Models

M944T3 and M40C3

Read this operator's manual thoroughly before starting to operate your equipment.  
This manual contains information you will need to run and service your new unit.

## Table of Contents

<b>INTRODUCTION</b> .....	2	<b>SERVICING (Continued)</b>	
Model Numbers .....	2	V-Belts .....	21
Serial Numbers .....	2	Valve Clearances.....	22
<b>WARRANTY</b> .....	3	Fuels - General.....	23
<b>SAFETY RULES</b> .....	3 - 7	Primary Fuel Filter.....	23
<b>LOCK OUT / TAG OUT PROCEDURES</b> .....	8	Primary Fuel Filter Element .....	23
<b>COMPONENT LOCATIONS</b>		Secondary Fuel Filter.....	23
M944T3 Generator Set .....	10 - 11	Bleeding the Fuel System .....	24
M40C3 Generator Set .....	12 - 13	Injector Service.....	25
<b>CONTROL PANELS</b> .....	14	Injection Pump.....	26
<b>OPERATING PROCEDURES</b>		Turbocharger .....	27
Emissions Related Instructions.....	15	Cooling System - General.....	28
Break-in Period.....	15	Checking Coolant Level .....	28
Before Starting.....	15	Cooling System Flushing.....	28
Starting.....	16	Heat Exchanger.....	29
Operating .....	16	Raw Water Pump .....	29
Stopping .....	16	Zinc Electrodes .....	29
Shutdowns and Alarms .....	17	Electrical System - General .....	29
Spare Parts .....	17	Booster Batteries.....	29
<b>SERVICING SCHEDULE CHART</b> .....	18 - 19	Generator End.....	30
<b>SERVICING</b>		Battery Care .....	31
Lubrication - General.....	20	Winterizing / Out-of-Service .....	31
Checking Oil Level.....	20	<b>TROUBLESHOOTING</b>	
Oil Changes .....	20	Electrical.....	32
Changing Lube Oil Filter.....	21	Engine.....	33 - 35
Air Cleaner.....	21	<b>WIRING DIAGRAMS</b>	
		AC Electrical .....	36 - 38
		DC Electrical .....	39 - 46
		Panel Diagrams .....	47 - 48

### Proprietary Information

This publication is the property of Northern Lights, Inc.

It may not be reproduced in whole or in part without the written permission of Northern Lights, Inc.

© Northern Lights, Inc. All rights reserved. Litho U.S.A. Publication number OM944T3 2/20

## Introduction

The servicing of marine engines and generator sets presents unique problems. In many cases, boats cannot be moved to a repair facility. Marine engines cannot be compared to the servicing of automobiles, trucks, or even farm equipment. Failures often occur in remote areas far from competent assistance. Marine engines are taxed far more severely than auto or truck engines; therefore, maintenance schedules must be adhered to

more strictly. Failures begin with minor problems that are overlooked and become amplified when not corrected during routine maintenance.

As operator, it is your obligation to learn about your equipment and its proper maintenance. This is not a comprehensive technical service manual. Nor will it make the reader into an expert mechanic. Its aim is to aid you in maintaining your unit properly.

## Unit Identification

### MODELS INCLUDED

This manual covers the operating instructions for:

**M944T3 and M40C3** marine and commercial generator sets, which use the 944 engine block, turbocharged.

## Model Numbers

Model numbers give the unit's application, block model, aspiration, and RPM:

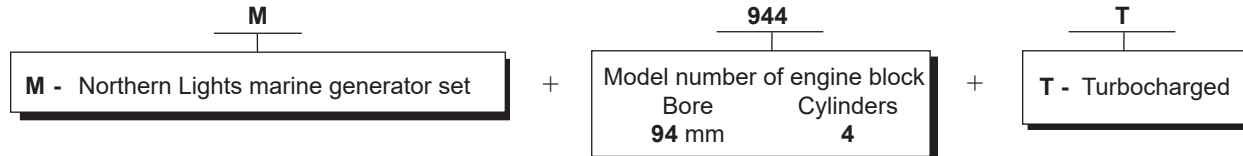

**M944T3** = Northern Lights marine diesel generator set with a 944 engine and a LX-E 34E series generator end.

**M40C3** = Northern Lights commercial marine diesel generator set with a 944 engine and a Newage series generator end, 40 kW.

## Serial Numbers



Your set has three serial numbers: ① an engine number stamped on a plate attached to the valve cover, ② a generator end serial number, and ③ a generator set serial number.

NOTE: Always use the generator set serial number when ordering parts or in correspondence. The generator set serial number plate is found on the service side of the generator and resembles the drawing in Figure 1.

*Figure 1: Generator set serial number plate.*

## Warranty

A warranty registration certificate is supplied with your set. It entitles the original purchaser of our equipment to a warranty covering material or assembly faults. The extent of coverage is described in the Limited Warranty Statement. We recommend that you study the statement carefully.

**NOTE:** If the warranty is to apply, the servicing instructions outlined in this manual must be followed. If further information is needed, please contact an authorized dealer or the factory.

## Safety Rules



**NOTICE:** Accident reports show that careless use of engines causes a high percentage of accidents. You can avoid accidents by observing these safety rules. Study these rules carefully and enforce them on the job.

### IMPORTANT SAFETY INSTRUCTIONS.

Electromagnetic equipment, including generator sets and their accessories, can cause bodily harm and life threatening injuries when improperly installed, operated or maintained. To prevent accidents be aware of potential dangers and act safely.

on parts and components from outside suppliers that is not reproduced in this manual. Consult the suppliers for additional safety information.

Learn how to operate the machine and how to use the controls properly. Only trained personnel should operate machines, or work on or around them.



**READ AND FOLLOW ALL SAFETY INSTRUCTIONS IN THIS MANUAL, PRIOR TO THE INSTALLATION OF ANY GENERATOR SET OR ACCESSORY. KEEP THESE INSTRUCTIONS FOR FUTURE REFERENCE.**

Keep you machine in proper working condition. **UNAUTHORIZED MODIFICATIONS TO THE MACHINERY MAY IMPAIR ITS FUNCTION AND SAFETY PARAMETERS.**

### Recognize Safety Symbols and Instructions

In addition to the information found in this section, this operator's manual uses three different signal words to outline potential dangers of a specific nature.

	<b>DANGER</b>	DANGER indicates a hazardous situation which, if not avoided, will result in death or serious injury.
	<b>WARNING</b>	WARNING indicates a hazardous situation which, if not avoided, could result in death or serious injury.
	<b>CAUTION</b>	CAUTION indicates a hazardous situation which, if not avoided, could result in minor or moderate injury.

### Prevent Bypass and Accidental Starting



Do not start engine by shorting across start terminal. Engine will start if normal circuitry is bypassed, creating a hazard by runaway machinery.



Start engine only from operator's station.

### Follow All Safety Instructions

Carefully read and understand all safety messages in this manual and on your machine's safety signs. Keep signs in good and clean condition. Replace missing or damaged signs. Be sure new equipment components and repair parts include the current safety signs. For replacement signs, proper placement of safety signs or clarification on any safety issue, consult your Northern Lights dealer or the factory.



There can be additional safety information contained

### Handle Fuel Safely - Avoid Flames



Diesel is highly flammable and should be treated with care at all times. Do not refuel while smoking or when near sparks or open flame.

**ALWAYS STOP ENGINE BEFORE FUELING MACHINE.** Always fill portable fuel tank outdoors. Never fuel a hot engine.



## Safety Rules (Continued)

Prevent accidental discharge of starting fluids by storing all cans in a cool, safe place, away from sparks or open flame. Store with cap securely on container. Never incinerate or puncture a fuel container.

Prevent fires by keeping machine clean of accumulated trash, grease and debris. Always clean any spilled fuel as swiftly as possible. Do not store oily rags, which can ignite and burn spontaneously.

Be prepared if a fire starts. Keep a first aid kit and fire extinguisher handy. Keep emergency contact numbers for fire department, doctors, ambulance and hospital near the telephone.

### Service Machines Safely

#### **! DANGER**

Do not wear a necktie, scarf, necklace, rings or other jewelry, or any loose clothing when working near moving parts. Tie long hair behind your head. If any of these items get caught in moving machinery, severe injury or death could result.

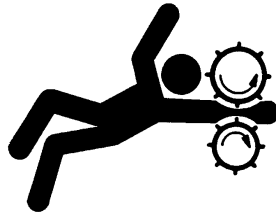

Check for any loose electrical connections or faulty wiring.

Look completely around engine to make sure that everything is clear before starting.

### Wear Protective Clothing

#### **! WARNING**

To prevent catching anything in moving machinery, always wear close fitting clothes and safety equipment appropriate to the job.

Prolonged exposure to loud noise can cause hearing loss or impairment.

Wear suitable authorized hearing protection, such as earmuffs or plugs to protect against loud noises

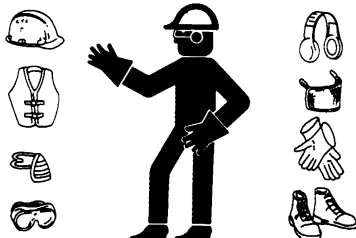

Operating equipment requires the full attention of the operator. Do not use radio or music headphones while operating machinery.

### Practice Safe Maintenance

#### **! CAUTION**

Understand all service procedures before starting work. Keep area clean and dry. Never lubricate, service, or adjust machine while it is in operation.



Keep hands, feet and clothing away from power-driven equipment. When shutting down an engine, disengage all power and operator controls. Allow the engine to cool completely before beginning any service work.

*Securely support any machinery elements that must be raised for service work with support or lifting machinery specifically intended for that purpose.*

Keep all parts in good conditions and properly installed. Fix damage immediately. Replace any worn or broken parts. Remove any build up of grease, oil or debris.

Disconnect battery ground cable (-) before making any adjustments or service work.

### Stay Clear of Rotating Drivelines

#### **! DANGER**

Entanglement in rotating drivelines can cause serious injury or death. Keep shields in place at all times. Make sure that rotating shields turn freely in pace with the drivelines.

Do not wear loose fitting equipment around rotating drivelines. Stop the engine and make sure that all moving parts have stopped before making any adjustments, connections, or performing any other type of service to the engine or other driven equipment.



## Safety Rules (Continued)

### Install all Safety Guards

#### **WARNING**

Direct contact with rotating fans, belts, pulley and drives can cause serious injury.

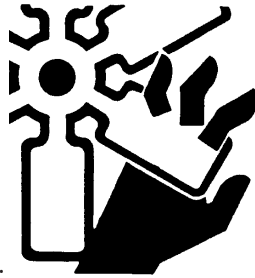

Keep all guards in place at all times during engine operation.

Wear close-fitting clothes. Stop the engine and be sure all fans, belts, pulleys and drives are stopped before making adjustments, connections, or cleaning near fans and their components.

Do not allow anything on your person to dangle into or come in contact with a moving fan, belt, pulley or drive. Fans can act as vacuums and pull materials up from below, so avoid that area as well while in service.

### Safe Battery Handling

#### **WARNING**

#### Prevent Battery Explosions

Battery gas is highly flammable. Battery explosions can cause severe injury or death. To help prevent battery explosions, keep sparks, lighted matches and open flame away from the top of battery. When checking battery electrolyte level, use a flashlight.



Never check battery charge by contacting the posts with a metal object. Use a volt-meter or hydrometer.

Frozen batteries may explode if charged. Never charge a battery that has not been allowed to warm to at least 16°C (60°F).

Always remove grounded (-) battery clamp first and replace ground clamp last.

Sulfuric acid in battery electrolyte is poisonous and strong enough to burn skin, eat holes into clothing and other materials, and cause blindness if splashed into eyes.

### To Avoid Hazards:

- Fill batteries only in well-ventilated areas.
- Wear appropriate eye protection and rubber gloves.
- Never use air pressure to clean batteries.
- Wear appropriate ventilation equipment to avoid inhaling fumes when adding electrolyte.
- Do not spill or drip electrolyte.
- Use correct jump-start procedure if required.

### If acid is spilled on skin or in eyes:

1. Flush skin with water.
2. Apply baking soda or lime to help neutralize acid.
3. Flush eyes with water for 15-30 minutes.
4. Get medical attention immediately.

### If acid is swallowed:

1. DO NOT induce vomiting.
2. Drink large amounts of water or milk, without exceeding 2 liters (2 quarts)
3. Get medical attention immediately

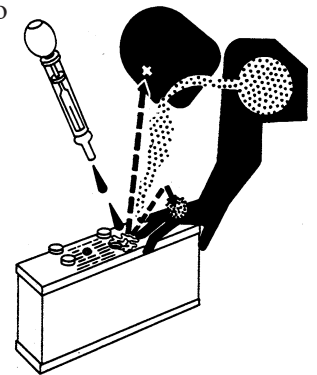

#### **WARNING**

Battery posts, terminals, and related accessories can contain lead and lead compounds, chemicals known to the State of California to cause cancer and reproductive harm. Wash hands after handling.

### Handle Chemical Products Safely

#### **WARNING**

Direct exposure to hazardous chemicals can cause serious injury. Among the potentially hazardous chemicals that may be used with Northern Lights products are lubricants, coolants, paints and adhesives.



All potentially hazardous chemicals come with a Material Data Safety Sheet (MSDS). The MSDS provides specific details on chemical products, including physical hazards, safety procedures and emergency response techniques

## Safety Rules (Continued)

Read and understand the MSDS for each chemical before you start any job that includes it. Follow the procedures and use appropriate equipment exactly as recommended.

Contact your Northern Lights dealer or Northern Lights factory for MSDS's used on Northern Lights products.

### Work in Well Ventilated Areas

#### **! CAUTION**

Exhaust fumes from engines contain carbon monoxide and can cause sickness or death. Work in well ventilated areas to avoid prolonged exposure to engine fumes. If it is necessary to run an engine in an enclosed area, route the exhaust fumes out of the area with an approved, leak proof exhaust pipe extension.

### Remove Paint Before Welding or Heating

#### **! WARNING**

Hazardous fumes can be generated when paint is heated by welding, soldering or using a torch. To avoid potentially toxic fumes and dust, remove paint before heating.



- Remove paint a minimum of 100 mm (4 in.) from the area that will be affected by heat.
- If paint cannot be removed, wear an approved respirator.
- If you sand or grind paint, use an approved respirator.
- If you use solvent or paint stripper, remove stripper with soap and water before welding. Remove solvent or paint stripper containers from the area.
- Allow at least 15 minutes for fumes to disperse before welding or heating.

Do not use a chlorinated solvent in an area where welding will occur. Work only in areas that are well ventilated. Dispose of paint and solvent properly.

### Service Cooling System Safely

#### **! WARNING**

Opening a pressurized cooling system can release explosive fluids and causing serious burns. Before opening any pressurized cooling system, make sure the



engine has been shut off. Do not remove a filler cap unless it is cool enough to comfortably grip with bare hands. Slowly loosen cap to relieve pressure before opening fully.

### Avoid High Pressure Fluids

#### **! WARNING**

Relieve pressure prior to disconnecting pressurized lines. Escaping fluid under pressure can penetrate the skin causing serious injury. Always relieve pressure before disconnecting hydraulic or other pressurized lines. Tighten all connections firmly before re-applying pressure.



If searching for leaks, use a piece of cardboard. Always protect your hands and other body parts from high-pressure fluids.

If an accident occurs, see a doctor immediately. Any high pressure spray injected into the skin must be removed within a few hours to prevent the risk of gangrene or other infection.

### Avoid Heating Near Pressurized Fluid Lines

#### **! WARNING**

Flammable spray can be generated by heating near pressurized fluid lines, resulting in severe burns and bodily injury. Pressurized lines can rupture when heat goes beyond the immediate flame area. Do not weld, solder or use a torch or open flame near pressurized lines or other flammable fluids.



### Do Not Open High-Pressure Fuel System

#### **! DANGER**

Many Northern Lights engines use high-pressure fuel injection. High-pressure fluid remaining in fuel lines can cause serious injury. Do not disconnect or attempt any repair of fuel lines, sensors, or other



## Safety Rules (Continued)

components between the high-pressure fuel pump and nozzles on engines with high pressure fuel systems.



**ONLY AUTHORIZED TECHNICIANS CAN PERFORM REPAIRS ON AN HIGH PRESSURE FUEL INJECTION SYSTEMS.**

### Avoid Hot Exhaust



Avoid exposure to and physical contact with hot exhaust gases. Exhaust parts and streams can reach high temperatures during operation, leading to burns or other serious injury.



Cleaning exhaust filters can also lead to exposure to hot exhaust gas and the injury risk associated with it. Avoid exposure to and physical contact with hot exhaust gases when cleaning exhaust filters.

During auto or manual/stationary exhaust filter cleaning operations, the engine will run at elevated temperatures for an extended period of time. Exhaust parts and streams can reach high temperatures during operation, leading to burns or other serious injury.

### Avoid contact with Turbo Housing



The unit's turbocharger reaches very high temperatures during operation. Avoid ALL direct contact with the turbocharger/

### Avoid Harmful Asbestos Dust



Inhaling asbestos fibers may cause lung cancer. Avoid breathing any dust that may be generated when handling components containing asbestos fibers, including some gaskets.



The asbestos used in these components is usually found in a resin or otherwise sealed. Normal handling of these components is not dangerous, as long as airborne dust containing asbestos is not generated. Avoid creating dust. Never use compressed air

for cleaning. Avoid brushing or grinding materials containing asbestos. When servicing, wear an approved respirator. A special vacuum cleaner is recommended to clean asbestos. If this vacuum is not available, apply a mist of oil or water on the material containing asbestos. Keep all bystanders away from any area where asbestos dust may be generated.

### Use Proper Lifting Equipment and Techniques



Lifting heavy components incorrectly can cause severe injury or damage to machinery. Avoid unbalanced loads. Do not use lifting eyes. Lift the generator set using lifting bars inserted through the lifting holes on the skid. Follow all recommended removal and installation procedures in this and associated Northern Lights manuals.

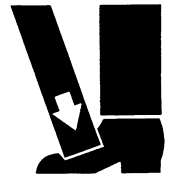

### Use Proper Tools



Makeshift tools and procedures can create safety hazards. Always use appropriate tools for the job.

Use power tools only to loosen threaded parts and fasteners. For loosening and tightening hardware, always use the correct sized tools.

Do not use US measurement tools on metric fasteners, or vice versa. Use only service parts that meet Northern Lights specifications.



### Dispose of Waste Properly



Disposing of waste improperly can threaten the environment and lead to unsafe working conditions. Potentially harmful waste used in Northern Lights equipment can include oil, fuel, coolant, filters and batteries.

Use leakproof containers to drain fluid. Do not use food or beverage containers that may mislead someone into drinking from them.

Do not pour waste onto the ground, down a drain or into any water source.

## Lock Out / Tag Out Procedures

### Scope

During maintenance, repairs or retooling of a Northern Lights generator set, simply turning the machine off or unplugging it while it is being worked on does not give enough protection to others who are not performing the maintenance or repair. Many serious accidents happen when someone thought the machine was turned off, or all of its energy was safely blocked or released.

### General Policy

#### **⚠ CAUTION**

To avoid dangerous or hazardous situations, refrain from any of the following:

- Removing or bypassing a guard or other safety device
- Placing any part of your body in a position where you could be caught by moving machinery.
- Cleaning or oiling machinery when in operation.
- Adjusting circuits, chillers, pumps, air handlers, valves, circuit breakers or fans while in operation.
- Working on piping or high pressure systems.

### Lock Out/Tag Out Instructions - Electrical Equipment

#### **⚠ WARNING**

Be sure the equipment's ON/OFF switch is in the OFF position and is unplugged from any electrical source before attempting to perform any type of work on the equipment. Obtain an electrical plug cap cover with a lockset. Secure the plug terminal end using the electrical plug lockout cap. Lock the cap and retain the key.

If the equipment is directly wired into an electrical box with a shut off switch, obtain a lock pad and/or the appropriate colored tags and place the lock and tag through the shut off lever. Retain the key until the repair is completed and the machine is safe to start. Be certain the shut off lever is in the OFF position before restarting. NEVER give a lock out key to unauthorized personnel.

If the equipment is directly wired into an electrical box without a shut off switch and lock out capability, then a circuit breaker lock out will be required. Obtain a circuit lock and tag set. Install the lock onto the circuit breaker box. Ensure the unit ON/OFF switch is in the OFF position before restarting.

### Lock Out/Tag Out Instructions - Pneumatic and Hydraulic Equipment

For servicing pneumatic and hydraulic equipment, the following additional procedures must be implemented, following completion of lock out/tag out procedures for the unit to be serviced:

Shut off air, water or supply valves at the equipment to be serviced.

Check the local bleed-off point for completed release of pressurized air, water or oil.

If shutting off of air, water or other material cannot be achieved at the local supply valve, shut off valves further back in the system and re-check the bleed-off point until complete shut-off is achieved.

Affix a DO NOT OPERATE tag to each valve handle that requires shut off. Each DO NOT OPERATE tag must be signed and dated by the authorized technician servicing the equipment.

### Lock Out/Tag Out Instructions - Air Hose Connected Pneumatic Equipment

#### **⚠ WARNING**

Equipment connected to the compressed air system through an air hose with a detachable fitting must be shutdown and unplugged. Excess air must be bled prior to removing the air hose, prior to any maintenance or repair activities.

Affix a DO NOT OPERATE tag to the air hose near the detachable fitting. Each DO NOT OPERATE tag must be signed and dated by the authorized technician servicing the equipment. Check that the equipment cannot be operated by activating the ON switch.

### Stored Energy

#### **⚠ WARNING**

Immediately after applying Lock Out or Tag Out devices, ensure that all potentially hazardous stored or residual energy is relieved, disconnected, restrained and otherwise rendered safe.

### Verification of Isolation

#### **⚠ CAUTION**

Verify the machinery or equipment is actually isolated and de-energized prior to beginning work on a machine or on equipment that has been locked out.

### Restarting Procedures

Follow the procedures below prior to restoring energy:

- Ensure that all machinery or equipment is properly reassembled. Inspect the machinery or equipment to verify non-essential items have been removed.
- Ensure that all personnel are safely outside danger zones. Notify personnel that lock out/tag out devices have been removed and energy will be reapplied.
- Only authorized personnel may remove lock out/tag out devices or notices.

---

**Notes**

---

## M944T3 Generator Set Component Locations

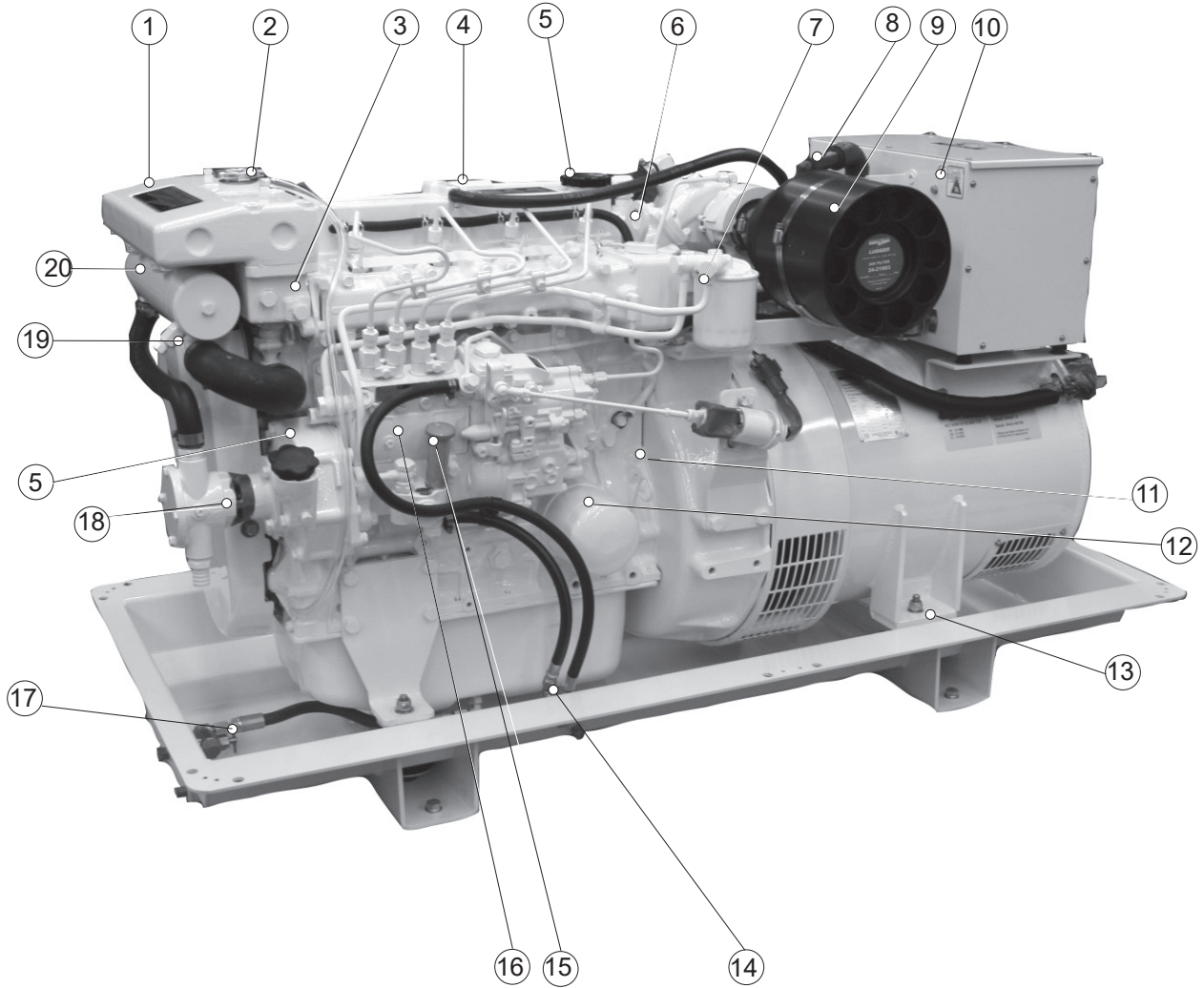

**Figure 2:** M944T3 Service Side

- |                       |   |  |
|-----------------------|---|--|
| 1. Expansion Tank     | 8. Breather                             | 15. Fuel Primer Pump                           |
| 2. Coolant Fill       | 9. Air Filter                           | 16. Injection Pump                             |
| 3. Thermostat Housing | 10. Junction Box                        | 17. Lube Oil Drain                             |
| 4. Rocker Arm Cover   | 11. Lube Oil Dipstick                   | 18. Raw Water Pump                             |
| 5. Lube Oil Fill      | 12. Oil Filter                          | 19. Heat Exchanger Raw Water<br>Drain and Zinc |
| 6. Intake Manifold    | 13. Vibration Mounts                    | 20. Heat Exchanger                             |
| 7. Fuel Filter        | 14. Fuel Supply &<br>Return Connections |  |

## M944T3 Generator Set Component Locations

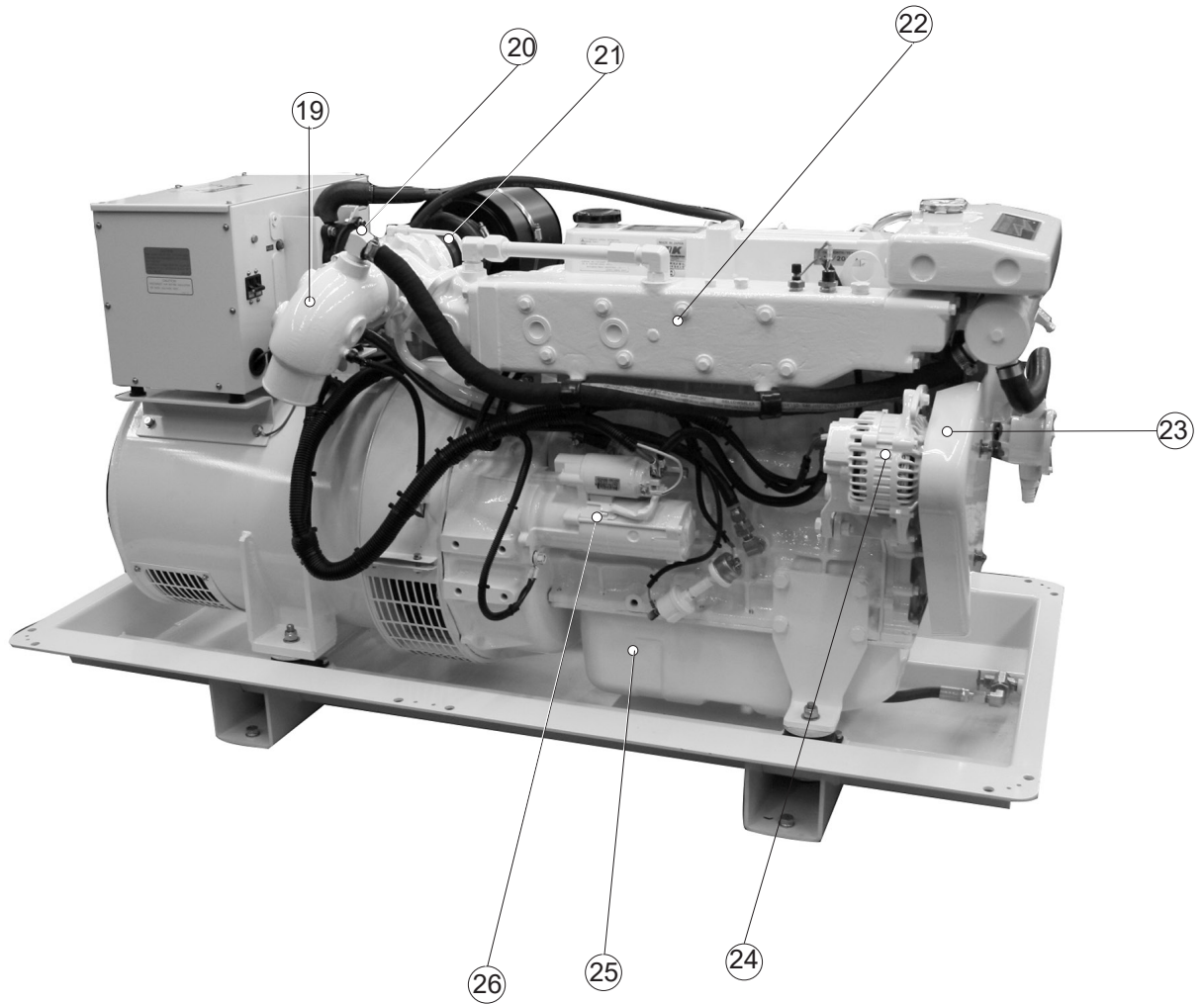

*Figure 3: M944T Non-Service Side*

- |                           |                |
|---------------------------|----------------|
| 19. Wet Exhaust Elbow     | 24. Alternator |
| 20. Turbocharger          | 25. Oil Pan    |
| 21. Dry Turbo Exhaust Lag | 26. Starter    |
| 22. Exhaust Manifold      |                |
| 23. Belt Guard            |                |

## M40C3 Generator Set Component Locations

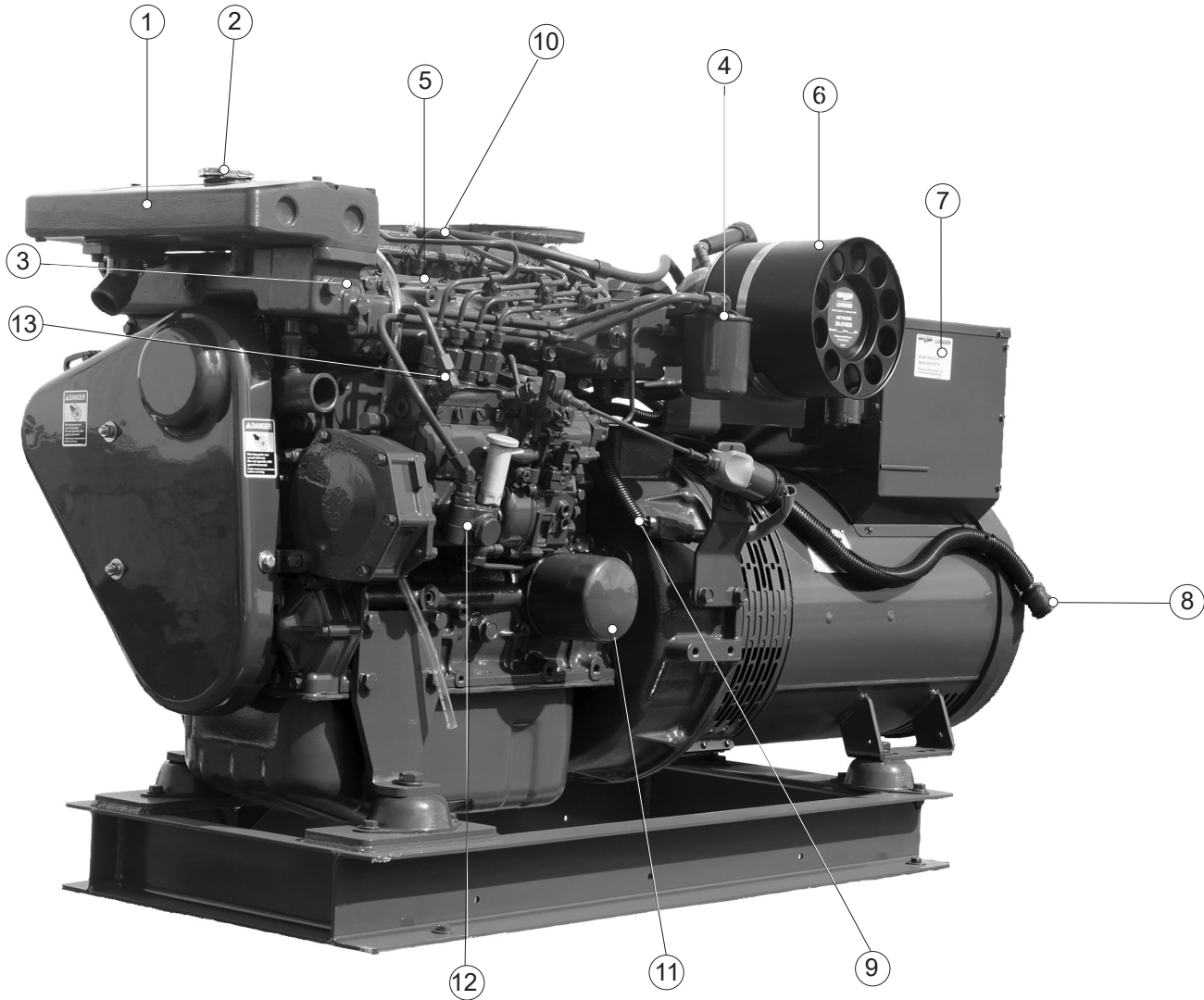

*Figure 4: M40C3 Service Side*

- |                       |                      |
|-----------------------|----------------------|
| 1. Expansion Tank     | 8. Harness Plug      |
| 2. Coolant Fill       | 9. Lube Oil Dipstick |
| 3. Thermostat Housing | 10. Oil Fill Cap     |
| 4. Fuel Filter        | 11. Oil Filter       |
| 5. Intake Manifold    | 12. Fuel Primer Pump |
| 6. Air Cleaner        | 13. Injection Pump   |
| 7. Junction Box       |                      |

## M40C3 Generator Set Component Locations

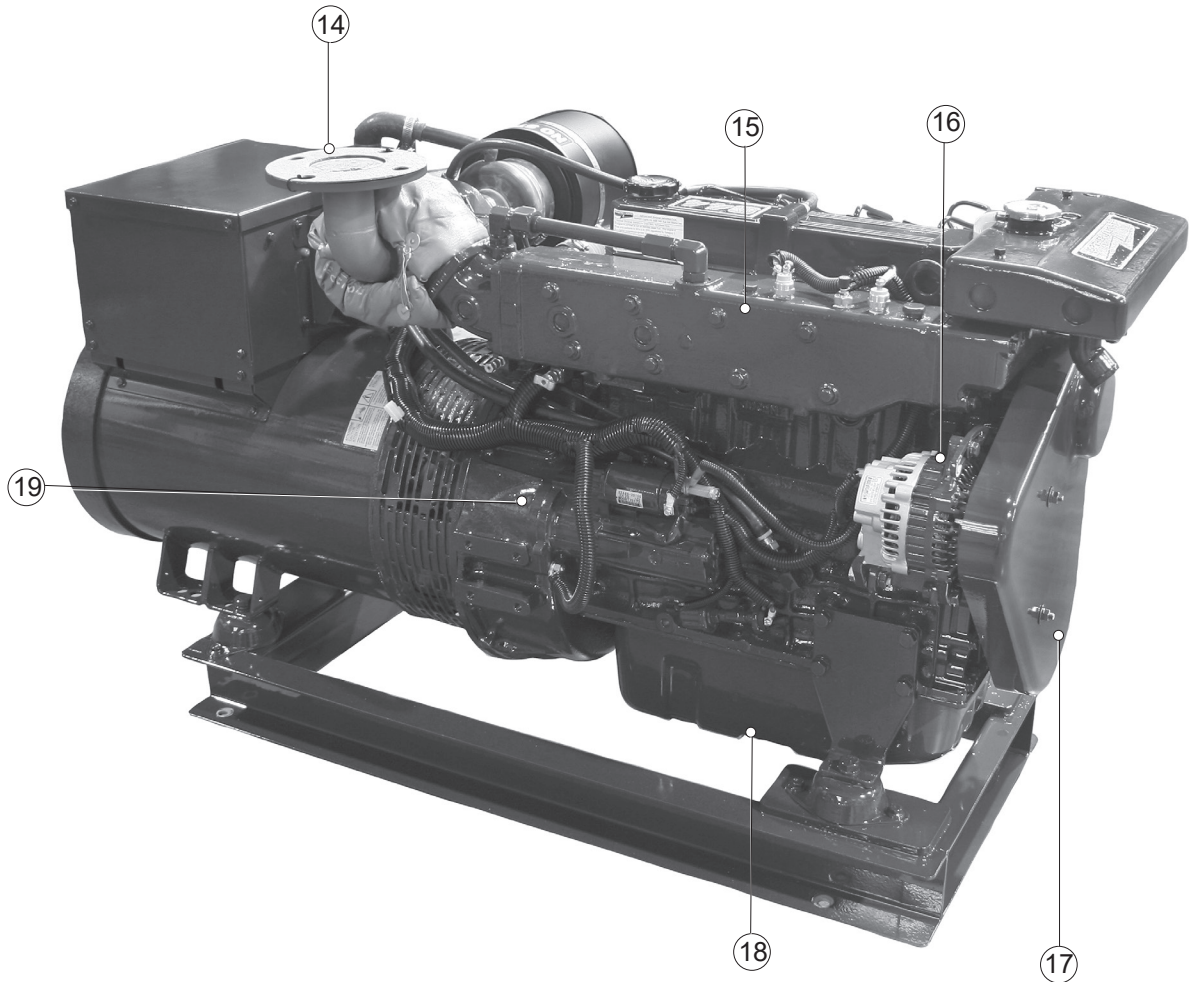

*Figure 5: M40C3 Non-Service Side*

- |                             |                    |
|-----------------------------|--------------------|
| <b>14.</b> Turbocharger     | <b>18.</b> Oil Pan |
| <b>15.</b> Exhaust Manifold | <b>19.</b> Starter |
| <b>16.</b> Alternator       |                    |
| <b>17.</b> Belt Guard       |                    |

## Control Panels

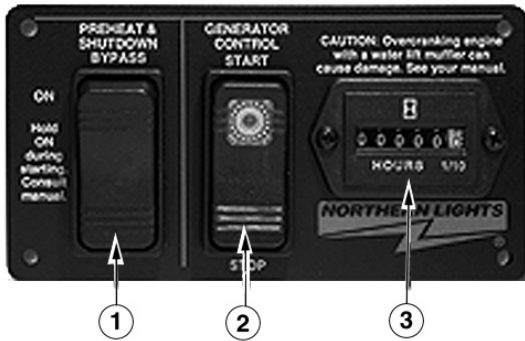

Figure 4: Series 1-B Generator Control Panel

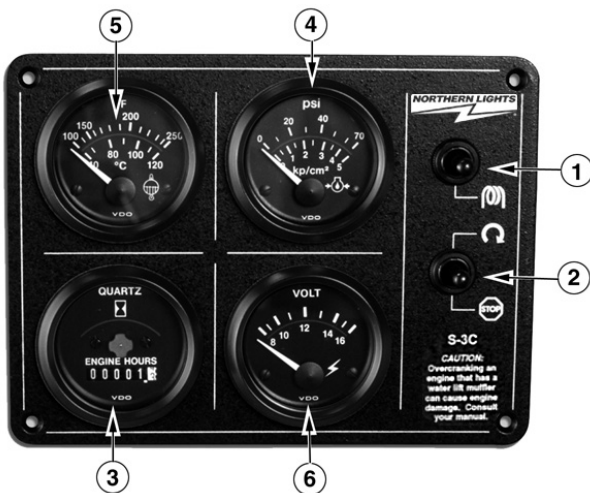

Figure 5: Series 3 Generator Control Panel

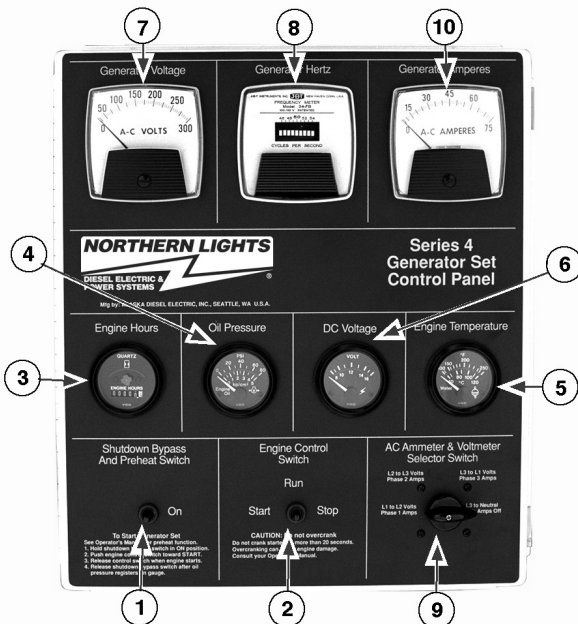

Figure 6: Series 4 Generator Control Panel

### 1. PREHEAT/ SHUTDOWN BYPASS

This switch serves two functions:

1. Preheats air before beginning the starting process. Press switch for 10-20 seconds before attempting startup.
2. Bypasses the safety shutdown feature during the starting process. Keep switch engaged while starting engine, and for 2 to 3 seconds afterwards, allowing oil pressure to build beyond shutdown setpoint.

### 2. ENGINE CONTROL SWITCH

To start the engine, hold this switch in the START position until the engine is running. After the engine starts, release the switch and it will return to RUN position. To stop the engine, hold the switch in the STOP position.

**NOTE:** The rocker switch is used on Series 1 panels only, and has a light that glows when the set is running.

### 3. HOUR METER

Keeps track of engine running time.

### 4. OIL PRESSURE GAUGE

Shows the oil pressure in the engine lubricating system.

### 5. WATER TEMPERATURE GAUGE

Registers the temperature of the cooling water.

### 6. D.C. VOLTMETER

When the engine is stopped, the voltmeter indicates the condition of the battery. When the engine is running, the voltmeter indicates the voltage output of the alternator.

**For Series 4 Control Panels only:**

### 7. A.C. VOLTMETER

Shows the generator output voltage.

### 8. FREQUENCY METER (Hertz)

The frequency meter indicates alternating current frequency: 60 Hz (1800 rpm) or 50 Hz (1500 rpm).

### 9. AMMETER/VOLTMETER SELECTOR

Used to check the voltage and current of each phase. Return to "Amps Off" position when not monitoring.

### 10. A.C. AMMETER

Shows the generator load on each phase. The phase is selected with the Ammeter Selector switch (#9).



---

## Emission-Related Installation & Instructions

---

Failing to follow these instructions when installing a certified engine in a vessel violates federal law (40 CFR 1068.105(b)), subject to fines or other penalties as described in the Clean Air Act.

The installed exhaust system should not create exhaust back pressure greater than 27" (685 mm) of water, measured at the engine exhaust elbow.

If you install the engine in a way that makes the engine's emission control information label hard to read during normal engine maintenance, you must place a duplicate label on the vessel, as described in 40 CFR 1068.105.

---

## Operating Procedures

---

### BREAK-IN PERIOD

1. The first 100 hours on a new or reconditioned engine are critical to its life and performance.
2. Constantly check the engine temperature and oil pressure gauges.
3. Oil consumption is greater during break-in as piston rings take time to seat.
4. Break-In Oil Changes: Change engine oil and filter at 50 hours. Change oil and filter again at 100 hours (consult Lubricants section for oil recommendation).

### Operating Instructions:

Maintain at least a 75% load on your generator set for the first 100 hours. If this is not possible, maintain no less than a 50% load to ensure proper seating of the piston rings. Vary the load to help seat the rings.

### BEFORE STARTING

1. Check the water level by removing the pressure cap from the expansion tank. In order to give the cooling water an opportunity to expand, the level should be about 1 in. (2.5 cm) below the filler cap sealing surface when the engine is cold.



---

**CAUTION:** Use protective clothing and open the filler cap carefully when the engine is warm to prevent burns.

---

2. Check the oil level in the crankcase with the dipstick. The oil level must be between high and low marks on the stick. Never allow the level to go below this area. Always add the same viscosity of oil as is already in the crankcase.
3. Check the fuel tank level and open any fuel valves on the tank and at the secondary fuel filter.
4. Close the sea-cock, check and clean the sea strainer, and reopen the sea-cock.
5. Place the battery switch in the ON position.

**NOTE:** The battery switch must always be kept ON while the engine is running. If the switch is turned OFF while the engine is running, the battery charging alternator could be damaged.

---

## Operating Procedures

---

### STARTING

1. Hold the Shutdown Bypass switch in the ON position.
2. While holding the Shutdown Bypass switch in the ON position, push the Engine Control switch to the START position.
3. As soon as the engine starts, release the start switch and continue to hold the bypass/preheat switch for an additional five seconds. Do not crank the starter for more than 10 seconds consecutively. If the engine fails to start with the first attempt, be sure that it has stopped completely before re-engaging.

**NOTE: Excessive cranking of the starter on marine sets equipped with a water lift muffler can cause engine damage. If the engine does not start after 3 consecutive 10-second cranks, remove the impeller from the seawater pump. This will prevent the muffler from filling with water and backfilling the exhaust line and engine. Once the engine starts, shut it off immediately and reinstall the impeller. Restart and check the exhaust overboard outlet for gushes of water.**

### OPERATING

1. Units with Series 3 and Series 4 Control Panels: check gauges often. Oil pressure must be above 15 PSI. The D.C. voltmeter should read between 11 and 15 volts at 80° F (25° C) ambient temperature. The water temperature gauge must be below 200° F (94° C). Check the A.C. voltage and frequency meters (Series 4 panel). If the gauges deviate from normal levels, shut down the generator set and investigate.
2. Add electrical load.

### STOPPING

1. Remove electrical load from the generator set.
2. Run the engine for a two to three minute cool-down period.
3. Move the Engine Control switch to the STOP position.

---

## Operating Procedures

---

### SHUTDOWNS AND ALARMS

1. Your unit is fitted with a system to protect it from high water temperature or low oil pressure.
  - a. Generator sets have shutdown systems to stop the engine. They have no warning horns.
  - b. Other alarms and shutdowns are available as optional equipment.

**NOTE: If your unit is equipped with optional shutdowns and alarms, do not rely on your warning or shutdown system to the exclusion of careful gauge monitoring. Watching your gauges can prevent damage to the unit and dangerous power losses.**

2. Do the following when your warning or shutdown system is activated:
  - a. Check the temperature gauge. If above 205° F (96° C), shut off the engine immediately.
  - b. Use the Trouble Shooting Guide on page 25 to isolate the cause of the overheat.



***CAUTION: Do not remove the water fill cap of an overheated engine. Escaping high temperature steam can cause severe burns. Allow the engine to cool and then remove the cap slowly using protective clothing.***

- c. Make repairs and restart after the temperature gauge registers below 200° F (94° C).
  - d. Watch the temperature gauge regularly and turn off the unit if the temperature rises above 205° F (96° C). Repeat troubleshooting.
3. If shutdown is activated and the temperature gauge shows temperature within normal temperature range:
  - a. Check the engine crankcase oil level.
  - b. If the oil level is low, fill with recommended lubricating oil and restart. Watch the oil pressure gauge carefully and shut off the engine if it does not show a normal reading (20-60 PSI) after a few seconds of operation.
  - c. If the oil level is normal, DO NOT restart the engine. Call your dealer for assistance.

### SPARE PARTS

1. Northern Lights recommends that you keep the following spare parts on hand for field service. Spare parts and world class spare parts kits are available from your local Northern Lights dealer.
  - a. Primary fuel filters
  - b. Oil filters
  - c. Air filter element
  - d. Drive belt
  - e. Thermostat and seal ring
  - f. Rocker arm cover gasket
  - g. Raw water pump impellers
  - h. Zinc anodes
2. Northern Lights standard spare parts kit (P/N 38-01207 or 38-01204)\* contains:
  - a. Primary fuel filters
  - b. Oil filters
  - c. Air filter element
  - d. Drive belt
  - e. Thermostat and seal ring
  - f. Rocker arm cover gasket
  - g. Raw water pump impellers
  - h. Zinc anodes
3. Intended for long-distance cruisers, Northern Lights world class spare parts kit (P/N 38-01205 or 38-01209)\* contains:
  - a. Primary fuel filters
  - b. Oil filters
  - c. Air filter element
  - d. Drive belt
  - e. Thermostat and seal ring
  - f. Rocker arm cover gasket
  - g. Raw water pump impellers
  - h. Zinc anodes
  - i. Fuel injector
  - j. Glow plug
  - k. Raw water pump
  - l. O-ring
  - m. 12VDC, 50A replay
  - n. Gasket kit
  - o. Workshop manual

\*- For use with M944T, M944T3 or M944T3F generator sets with heat exchangers. Consult your Northern Lights dealer for your unit's specific spare parts requirements.

## Servicing Schedule Chart

The Servicing Schedule Chart below shows the service schedule required for proper maintenance of your generator set. More detailed coverage of each Service Point (SP) is listed on the page noted in the 'page' column.

**DAILY:**

- Inspect for any signs of fluid leaking
- SP1 Check oil level in engine
- SP8 Check primary fuel filter
- SP14 Check cooling water level
- Check sea strainer

**AFTER FIRST 50 HOURS:**

- SP2-3 Change engine oil and filter
- SP5 Check V-belt tension
- SP19 Check electrolyte level in batteries

**EVERY 50 HOURS:**

- SP5 Check V-belt tension
- SP19 Check electrolyte level in batteries

**AFTER FIRST 100 HOURS:**

- SP2-3 Change engine oil and filter

**EVERY 250 HOURS:**

- SP2-3 Change engine oil and filter
- SP4 Check air cleaner
- SP13 Check turbocharger
- SP18 Check zinc electrodes

**EVERY 500 HOURS:**

- SP6 Check valve clearances
- SP8 Change primary fuel filter element
- SP9 Change secondary fuel filter
- SP11 Check injectors
- SP14-15 Check cooling system
- SP17 Change impeller
- SP20 Check battery charge with hydrometer

**EVERY 2000 HOURS or as needed:**

- SP4 Change air cleaner
- SP12 Check fuel injection pump
- SP16 Check and clean heat exchanger

SERVICE POINT	PAGE	OPERATION	DAILY	50 Hours	100 Hours	250 Hours	500 Hours	2000 Hours
<b>ENGINE:</b>								
SP1	20	Check oil level	•					
SP2	20	Change engine oil <sup>1,5</sup>		•	•	•		
SP3	21	Change lube oil filters <sup>1,5</sup>		•	•	•		
SP4	21	Check air cleaner <sup>1,3,4</sup>				•		•
SP5	21	Check V-belt tension <sup>1,5</sup>		•				
SP6	22	Check valve clearances <sup>1,8</sup>					•	
<b>FUEL SYSTEM:</b>								
SP7	23	Check primary filter <sup>2</sup>	•					
SP8	23	Change primary filter element <sup>1,2,3</sup>					•	
SP9	23	Change secondary fuel filter <sup>1,3</sup>					•	
SP10	24	Bleed the fuel system <sup>3</sup>						
SP11	25	Check injectors <sup>1,6</sup>					•	
SP12	26	Check fuel injection pump <sup>3</sup>						•
<b>TURBOCHARGER:</b>								
SP13	27	Check air, oil, & or leakage <sup>1</sup>				•		
<b>COOLING SYSTEM:</b>								
SP14	28	Check cooling water level	•					
SP15	28	Check and flush cooling system <sup>7</sup>						•
SP16	29	Check and clean heat exchanger <sup>3</sup>						•
SP17	29	Change impeller in raw water pump <sup>1,3</sup>					•	
SP18	29	Check zinc electrodes <sup>3</sup>				•		
<b>ELECTRICAL SYSTEM:</b>								
SP19	31	Check electrolyte level in batteries <sup>1,3</sup>		•				
SP20	31	Check condition of batteries with hydrometer <sup>1</sup>					•	
<b>OUT OF SERVICE:</b>								
SP21	31	Winterizing or out-of-service <sup>3</sup>						

1) Perform maintenance once a year even if hour level has not been reached.  
 2) Consult manufacturer's maintenance schedule, note on chart.  
 3) Or whenever necessary.  
 4) Change at 1000 hours.

5) After first 50 hours.  
 6) Fuel inj. valve opening pressure: 11.77 MPa (120 kgf/cm<sup>2</sup>)  
 7) Or every 2 years.  
 8) Valve clearance = .25 mm (0.0098").

## Service Record

Service Point	OPERATION	HOURS/ DATE									
<b>50 HOURS</b>											
SP5	Check V-belt tension										
SP19	Check electrolyte in batteries										
<b>250 HOURS</b>											
SP2	Change engine oil										
SP3	Change lubricating oil filters										
SP4	Check air cleaner										
SP13	Check turbocharger										
SP18	Check zinc electrodes										
<b>EVERY 500 HOURS</b>											
SP6	Check valve clearances										
SP8	Change primary filter element										
SP9	Change secondary fuel filter										
SP11	Check injectors										
SP15	Flush cooling system										
SP17	Change impeller in seawater pump										
SP20	Check condition of batteries with hydrometer										
<b>2000 HOURS or as required</b>											
SP-4	Change air cleaner										
SP12	Check fuel injection pump										
SP16	Check and clean heat exchanger										

**Service Notes:**

## Servicing

### LUBRICATION - GENERAL

1. Use only clean, high quality lubricants stored in clean containers in a protected area.
2. These lubricants are acceptable:
  - a. API Service CD, CE, and CF-4 single viscosity oils.
  - b. API Service CD, CE, and CF-4 multi-viscosity oils.
3. Use the proper weight oil for your average operation temperature.

Air Temperature	Multi-Viscosity
Above 32° F (0° C)	SAE 15-40W
-10° to 32° F (-23° to 0° C)	SAE 10-30W

Figure 7: Lube Oils

4. Never put additives or flushing oil in crankcase.

### SP-1. CHECKING OIL LEVEL

1. Ensuring that the engine is stopped, check the oil level in the crankcase daily. The oil level must be between the high and low marks on the stick. Fill with recommended oil (see Figure 7) and fill only to the high mark on the dipstick.

### SP-2. OIL CHANGES

1. The set is delivered with special break-in oil. Change the engine oil and oil filter after 50 hours of operation. Use diesel-rated break in oil (John Deere pre-packaged or equivalent) during the first 100 hours. Consult your dealer for more information.
2. Change the oil and filter again at 100 hours using the oil recommended in the above paragraph. After this, change oil and filter every 250 hours.
3. During intermittent cold weather operation, change oil level every 1000 hours or six weeks, whichever comes first.
4. Change oil at any seasonal change in temperature when a new viscosity of oil is required.
5. Change oil when engine is warm but not hot.
6. Dispose of waste oil in an approved manner.
7. Never use a flushing oil.
8. Loosen clamp on oil change tube. Remove cap. Drain oil. Replace cap and tube.
9. Refill engine with recommended oil.
10. Engine capacity with new oil filter is:  
.....2.64 gallons (10 liters)

---

## Servicing

---

### SP-3. CHANGING LUBE OIL FILTER

1. Change the lube oil filter every 250 hours.
2. Use a filter wrench to remove old filter. Dispose of filter in approved manner.
3. Make sure the gasket from the old filter is removed and discarded. Clean mount face.
4. Spread a thin film of engine oil on the rubber gasket on the new filter and screw it on nipple until gasket meets the sealing surface.
5. Using hands only – no wrench – tighten filter one-half turn farther. Overtightening can do damage to filter housing.
6. Fill engine with recommended oil. Start engine and check for leakage. Stop engine, wait 3 minutes, and check oil level. Add additional oil if necessary.
7. Oil filter part number is:  
.....#24-01201

### SP-4. AIR CLEANER

1. Visually inspect air cleaner every 250 hours.
2. Take off the hose clamp on the bracket and the hump hose to detach the air cleaner.
3. Make sure the hump hose is clean inside and also that the new filter element is absolutely clean and installed properly.

**Note: Make absolutely sure no impurities enter the engine while changing the element, and do not run the engine with the air cleaner removed.**

**Do not clean the filter with diesel fuel, solvent, or gasoline. Serious engine damage can result.**

### SP-5. V-BELTS

1. Check the tension and wear on the V-belt after 50 hours.
2. Use your thumb to press on the belt at the midpoint between the crankshaft and alternator pulleys. The tension is correct if the belt can be depressed about 10-12 mm (approximately 1/3" to 1/5") with 10 kg (22 lbs.) force.

## Servicing

### SP-6. VALVE CLEARANCES

1. Readjust valve clearance after first 50 hours of operation. Check valves every 500 hours thereafter.
2. Check the valves when the engine is cold.
3. Rotate the crankshaft in a clockwise direction in the front 180° to bring each piston to the top dead center on the compression stroke. Top dead center (TDC) is when notch on the pulley aligns with the pointer and the two valves on cylinder No. 1 “rock”. Rocking is when the rocker arms (for the two valves on a given cylinder) are moving in opposite directions, one up closing the valve and one down opening the other valve. The moment when the two rocker arms are exactly aligned with each other is when they “rock”.

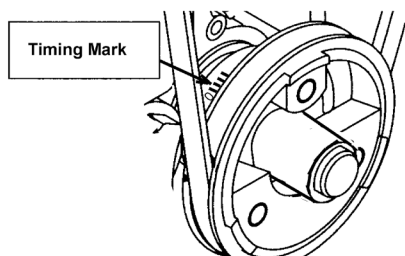

*Figure 8: Timing Mark*

4. Measure the valve clearance for each of the valves, with a feeler gauge, in the firing order (1-3-4-2). Standard valve clearances for a cold engine are:  
Intake (IN).....0.0098 in. (0.25 mm)  
Exhaust (EX).....0.0098 in. (0.25 mm)
5. To adjust valve clearance, loosen the lock nut on the adjustment screw. Insert a feeler gauge between the rocker arm and the valve stem cap. Adjust, while measuring the clearance, until the feeler gauge slides with a slight drag. Tighten the lock nut and recheck the clearance (Figure 9).

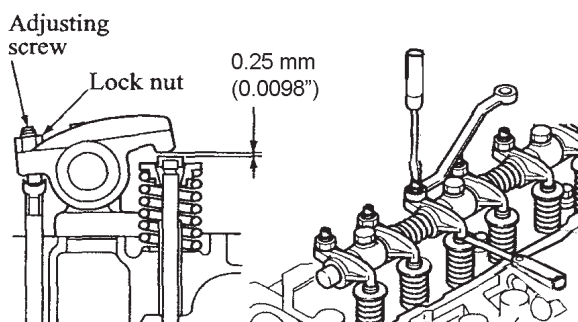

*Figure 9: Valve Adjustment*

6. Adjust the remaining valves.
7. Replace the rocker arm cover.



---

## Servicing

---

### FUELS - GENERAL

1. Use only clean, high quality fuels of the following specifications, as defined by ASTM designation D975 for diesel fuels:
  - a. Use grade No. 2 diesel at ambient temperatures above freezing 32° F (0° C).
  - b. Use grade No. 1 at ambient temperatures below freezing.
  - c. International fuel specifications:  
JIS K2204  
ISO-8217-DMA  
BS 2869 Part 1 Class A1  
BS 2869 Part 2 Class A2
2. Use fuel having less than 0.2% sulphur of weight (less than 0.05% recommended).
3. The cetane number should be 45 or higher.
4. Particulate contaminate should be 5.0 mg/l (0.00018 oz/U.S. gal) or lower.
5. DO NOT use these unsuitable grades of fuel:
  - a. Domestic heating oils, all types.
  - b. Class B engine.
  - c. Class D domestic fuels.
  - d. Class E, F, G or H industrial or marine fuels.
  - e. ASTM-D975-60T No. 4-D and higher number fuels.
6. Storing fuel:
  - a. Keep dirt, scale, water, and other foreign matter out of fuel.
  - b. Avoid storing fuel for long periods of time.
  - c. Fill the fuel tank at the end of each day's operation. This will reduce condensation.

### SP-7. PRIMARY FUEL FILTER

- a. Check the primary fuel filter daily as recommended by the filter manufacturer.

### SP-8. PRIMARY FUEL FILTER ELEMENT

- b. Change the element as often as necessary or every 200 hours.
- c. If the bowl fills with water, change the primary and secondary element immediately.

### SP-9. SECONDARY FUEL FILTER

- d. Change the engine mounted filter as often as necessary or every 250 hours.
- e. Remove the fuel filter with a filter wrench.
- f. Apply a coating of fuel to the o-ring of the new fuel filter.
- g. Tighten the new filter by hand, do not use a filter wrench for tightening.
- h. The filter should be dry.
- i. Do not add fuel to the fuel filter before installation, as this could cause unfiltered fuel to enter the fuel pump.
- j. Bleed the air out of the filter.

The fuel filter part number is:

**24-51201**

## Servicing

### SP-10. BLEEDING THE FUEL SYSTEM



**CAUTION:** Escaping diesel fuel under pressure can penetrate skin causing serious personal injury. Before disconnecting lines be sure to relieve all pressure. Before applying pressure, be sure all connections are tight and lines, pipes and hoses aren't damaged. Fuel escaping from a very small hole can be almost invisible. Use a piece of cardboard or wood, rather than hands, to search for suspected leaks. If injured by escaping fuel, see a doctor at once. Serious infection or reaction can develop if proper medical treatment is not administered immediately.

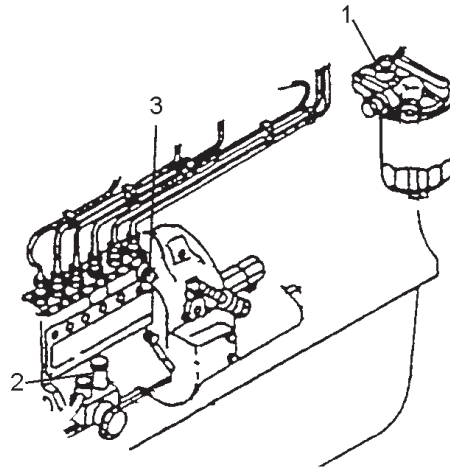

Figure 10 Fuel Feed Pump

1. Fuel system air bleeding may be needed when:
  - a. After fuel has been added to a newly installed engine.
  - b. A new fuel filter is installed.
  - c. The engine has run out of fuel.
  - d. The fuel lines, injection pump, or any other fuel system component has been removed and installed.
2. After changing the fuel filter, air only needs to be bled from the fuel filter. To do this:
  - a. Loosen the air vent plug (#1 on Figure 10) on the fuel filter by about 1-1/2 turns. (Be sure to cover the vent with a cloth to prevent fuel from splashing.)
  - b. Turn the priming pump cap on the fuel feed pump counterclockwise to unlatch it. Move the priming pump plunger (#2 on Figure 10) up and down. To close the pump turn the cap clockwise while depressing it.
  - c. Close the air vent plug when no more air bubbles can be seen in the fuel flowing from the air vent plug hole.
3. To bleed air at the fuel injection pump:
  - a. Turn the air vent plug (#3 on Figure 10) about 1-1/2 turns to loosen it. (Cover the vent with a cloth to prevent fuel from splashing.)
  - b. Pump the feed pump cap up and down.
  - c. When there are no air bubbles to be seen in the fuel flowing from the air vent plug hole, push down the priming pump cap and turn it clockwise to lock it in place.

#### NOTE:

**Do not close the air vent plug before locking the priming pump cap in place, because the internal pressure in the pump will prevent the priming pump cap from returning to the original position.**

4. If the engine does not start after this bleeding process, loosen a fuel line at the injector while cranking the engine with the starter motor until pure fuel escapes. Then tighten the connections. Do each line one-at-a-time. After the engine has started, use a piece of cardboard to look for fuel leaks.

---

## Servicing

---

### SP-11. INJECTOR SERVICE

1. Injectors should be checked every 500 hours. This check should be made by a Northern Lights dealer or local injection repair station.



**CAUTION:** Escaping diesel fuel under pressure can have sufficient force to penetrate the skin causing serious personal injury. If injured by escaping fuel, see a doctor at once.

2. Injector removal:
  - a. Clean loose dirt from around the injectors and the fuel lines.
  - b. Relieve high pressure in the fuel lines by loosening the delivery line flare nuts at each injector.
  - c. Remove delivery lines by disconnecting them from the injectors and injection pump. Remove all lines as an assembly; do not remove the spacers. Cover the ends of the lines, the injector inlets, and the injection pump outlets to keep dirt out.
  - d. Remove the return line retaining bolts, washers, and return line.
  - e. Loosen the injector retaining nuts at the same time a little at a time. Remove the injector.
  - f. Remove the injector seat. Cover the holes to prevent debris from entering the cylinders.

**Note:** Do not use pry bars to remove injectors from the cylinder head.

3. Injector repair and cleaning:
  - a. Take injectors to your Northern Lights dealer or local injection repair station for testing and service.
4. Injector installation:
  - a. Install new injector seal washer seat and injector. Evenly tighten the injector retaining nuts to 18.1 to 25.3 ft/lbs (24.5 to 34.3 N•m), or 2.5 to 3.5 kgf•m. Do not overtighten.
  - b. Reinstall the return line using new sealing washers. Tighten bolts to 13.0 to 15.9 ft/lbs (17.7 to 21.6 N•m), or 1.8 to 2.2 kgf•m.

**NOTE:** Overtightening can damage injectors.

- c. Reinstall injection lines. Tighten flare nuts at injection pump to 19.5 to 23.9 ft/lbs (26.5 to 32.4 N•m), or 2.7 to 3.3 kgf•m. Leave the lines loose at injectors for bleeding.
- d. Bleed the injection lines. Crank the engine to fill the lines. Tighten flare nuts at injectors to 14.5 to 17.4 ft/lbs (21.0 to 23.0 N•m), 2.0 to 2.4 kgf•m.
- e. Start the engine and check for leaks using a piece of paper or cardboard. Do not use your hand to check for leaks.

## Servicing

### SP-12. INJECTION PUMP

1. Since operating conditions may vary considerably, it is difficult to give a definite interval for checking the injection pump. But as a rule, pump settings, maximum speed, and exhaust smoke should be checked after every 2000 hours of operation. Service of the fuel injection pump should only be done if checks indicate pump malfunction.
2. Black smoke can be an indication of pump malfunction. Before servicing the pump, check other possible causes:
  - a. Check cleanliness of the air filter.
  - b. Check valve clearances.
  - c. Clean and check injectors.
3. Any repair which involves disassembly of the injection pump must be carried out by specially trained mechanics with the proper tools and test equipment.

**NOTE: All warranties on the engine become null and void if the injection pump seals are broken by unauthorized persons.**

#### 4. Injection Pump Removal:



**CAUTION: Escaping diesel fuel under pressure can have sufficient force to penetrate the skin, causing serious personal injury. If injured by escaping diesel fuel, see a doctor at once.**

- a. Clean the injection pump, hoses, and area around the pump with a cleaning solvent or steam cleaner.

**NOTE: Never steam clean or pour cold water on an injection pump while the engine is running or the pump is warm.**

- b. Remove the injection lines from the pump and injectors. Remove all lines as an assembly. Do not remove the spacers. Cover the ends of the lines, the injector inlets, and the injection pump outlets to keep dirt out of the injectors, lines, and pump.

- c. Remove the injection pump drive gear cover plate and the sea water pump.
- d. Align timing marks on timing gears.
- e. Remove the pump support bracket on rear of pump.
- f. Remove the 4 mounting nuts.
- g. Take the pump to your Northern Lights dealer or an injection repair station for testing and service.

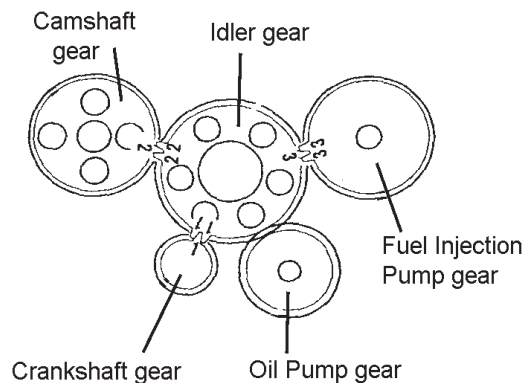

Figure 11: Timing Marks

5. Injection Pump Installation:
  - a. Install the fuel injection pump after having aligned its gear alignment mark with that of the idler gear alignment mark as shown in Figure 11 above. When the alignment marks of the timing gears align as in the diagram to the right, the No. 1 piston is top dead center in the compression stroke.
  - b. Install the injection pump to the side of the engine first then put in the end bolts, and then the tube with its bolts, and then the side bracket.
  - c. Torque mounting bolts to 13.0 - 18.1 ft/lbs (17.7 to 24.5 N•m), 1.8 to 2.5 kgf•m.

---

## Servicing

---

### **SP-13. TURBOCHARGER**

1. Check for air leaks every 250 hours. Air leakage will lower engine output and may cause black exhaust smoke and soot.
2. Listen along air line while the engine is running. A whistling or hissing sound could indicate leakage.
3. Leakage on the pressure side, between turbo and engine, can be found by applying soapy water to the air line.
4. Tighten the hose clamps and replace hoses or gaskets as required.
5. Check to see that the lubrication and cooling lines are tight and without leaks.

## Servicing

### COOLING SYSTEM - GENERAL

**NOTE:** Be sure to close the sea-cock before working on the engine cooling system.



**CAUTION:** The cooling water in the engine reaches extremely high temperatures. You must use extreme caution when working on hot engines to avoid burns. Allow the engine to cool before working on the cooling system. Open the filler cap carefully, using protective clothing when the engine is warm.

### WATER QUALITY

1. Distilled, deionized, soft water is preferred for use in cooling systems. Bottled distilled water from a food store or water supplier is recommended. Tap water often has a high mineral content. Tap water should NEVER be put in a cooling system unless first tested by a water quality laboratory. Do not use water made by the reverse osmosis method unless it has been PH neutralized.
2. Here are acceptable water quality specifications:

Contaminates	Parts per Million	Grains per Gallon
Maximum Chlorides	40	2.5
Maximum Sulfates	100	5.9
Maximum Dissolved Solids	340	20.0
Maximum Total Hardness	170	10.0
PH Level 5.5 to 9.0		

3. If chlorides, sulfates or total dissolved solids are higher than the above given specification, the water must be distilled, demineralized, or deionized before it is used in a cooling system.
4. If total hardness is higher than 170 ppm and all other parameters are within the given specifications, the water must be softened before it is used to make coolant solution.

### SP-14. CHECKING COOLANT LEVEL

1. Check the coolant level each day before starting the engine.
  - a. Check the water level by removing the pressure cap from the expansion tank. In order to give the cooling water an opportunity to expand, the level should be about 1 in. (2.5 cm) below the filler cap sealing surface when the engine is cold.
  - b. Soft water with about a pH about 6.5 to 8.5 combined with an antifreeze in a 30% to 50% (maximum) solution should be used.
  - c. The antifreeze should not contain amine, silicate, or borate.

### SP-15. COOLING SYSTEM FLUSHING

1. Flush the cooling system every 2000 hours or every 12 months, whichever comes first.
2. Remove fill cap and open drains on engine block. The engine block drain is on the service side of the engine above the dipstick, next to the flywheel housing.
3. Pour clean water into the engine until water coming from engine is clear of discoloration. Close drains and refill the engine with recommended coolant mixture.
4. Use 50% water / 50% (maximum) ethylene glycol antifreeze mix. Antifreeze mixture is recommended as a good year-round coolant.
5. Coolant capacity is approximately 3 gal. (11.4 liters).
6. Check hoses and connections and repair any leakage.
7. Start the engine and check for leaks. Run the engine for five minutes, then shut it down. Let engine cool, and then check the coolant level in the engine. Add coolant as needed.

**NOTE:** Be sure to open the sea-cock after working on the engine cooling system and starting the engine.

---

## Servicing

---

**SP-16. HEAT EXCHANGER**

1. Clean the heat exchanger core as needed.
2. Drain the expansion tank and heat exchanger.
3. Remove the heat exchanger end covers.
4. Clean the inside of the exchanger core tubes using a metal rod. Flush, inspect, and clean again if necessary.

To remove scaling, cleaning the heat exchanger using a 50/50 mix of muriatic acid and water may be necessary. The heat exchanger will need to be removed from the generator. **To be performed only by qualified technician.**

5. Reassemble the heat exchanger. Fill the cooling system. Start the engine and check for leaks.

**SP-17. RAW WATER PUMP**

1. Change the raw water pump impeller every 500 hours, or as needed.
2. Remove the pump cover. Pry out the impeller using needle-nose pliers or two screwdrivers. Be sure to remove all pieces of the failed impeller.

**NOTE: Place some kind of protection under the screwdrivers in order to not damage the pump housing.**

3. Clean the inside of the housing.
4. Press in the new impeller and place the sealing plug in the outer end of the impeller center if this has not already been done.

**NOTE: Make sure that there is always an extra impeller and cover gasket in reserve on board.**

**SP-18. ZINC ELECTRODES**

1. A zinc electrode is installed in the heat exchanger cooling system to protect the engine from electrolysis. Check it faithfully every 250 hours. If you are in warm saltwater, or where electrolysis is a known problem, check it more often. Wear rate of zinc varies from vessel to vessel. Operators will develop their own service schedule based on observed wear pattern.
2. Remove the zinc holder from the bottom of the exchanger. This will drain raw water from the exchanger.
3. Scrape or steel brush the zinc electrode clean. If more than 50% of the electrode is corroded away, replace it with a new zinc. The electrode screws out of the holder.
4. Reinstall the zinc holders. Be sure the threads are clean for good metal-to-metal contact. Do not use thread sealant.
5. Refill the cooling system. Start the engine and check for leaks.

---

## Servicing

---

### GENERATOR END

The maintenance and operation recommendations for the generator end are in a separate Owner's Manual (OPX300K2 or OLXE, check generator end part number for correct manual)

Megger generator end windings every two years.

Generator end bearings should be replaced every 10,000 hours.

If you do not have one of these manuals, they can be obtained through the Northern Lights web site [www.northern-lights.com](http://www.northern-lights.com).

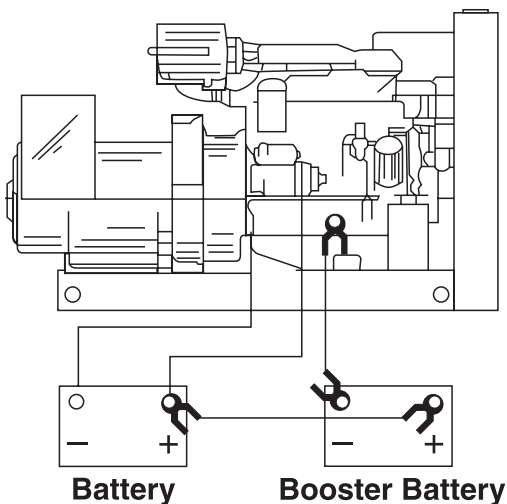

**Figure 12:** *Booster Battery Connections*

### ELECTRICAL SYSTEM - GENERAL



1. Never switch the battery switch off or break the circuit between the alternator and the batteries while the engine is running. Alternator damage can result.

2. Do not reverse the polarity of the battery cables when installing the battery.

### BOOSTER BATTERIES

**CAUTION:** *Battery gas can explode. Keep all flames and sparks away from batteries.*

1. Before changing or using booster batteries, check the battery electrolyte level. Add distilled water if necessary.

2. Booster and main batteries must have the same voltage rating.

3. First, connect the positive (+) terminal of the booster battery to the positive (+) terminal of the main battery. Then, connect the negative (-) terminal of the booster battery to ground on the engine block (Figure 10).

4. Remove the booster battery after starting the engine.

5. Sealed Batteries:

See the manufacturer's charging and booster instructions.



---

## Servicing

---

### SP-19 and 20. BATTERY CARE

1. Check the electrolyte level every 50 hours, or once a month. Add distilled water to the manufacturer's recommended level.
2. Batteries, cables, and cable terminals should be checked and cleaned every 100 hours. Clean corrosion with a water and baking soda solution. Flush with clean water. Tighten terminals and grease them to inhibit future corrosion.
3. Check the battery condition with a hydrometer every 500 hours.

### SP-21. WINTERIZING / OUT-OF-SERVICE

**NOTE: Remember to close the sea-cock before opening drain cocks.**

If the generator set will not be used for more than 3 months the following preparations should be taken for long term storage.

- Change engine oil and filter, as per recommendations on page 16.
- Run the engine up to at least 140° F from a small, clean source of fuel dosed with either “Stab-il” brand fuel system stabilizer (diesel engine formula), or Stanadyne Performance fuel system conditioner. If neither of these fuel treatments is available, you may also use John Deere fuel system conditioner.
- Completely drain, flush, and fill the cooling system with pre-mixed, 50/50, conventional ethylene-glycol heavy-duty diesel engine coolant.
- Loosen alternator drive belt.
- Completely seal off intake and exhaust openings with heavy plastic bags and duct tape.
- Cover entire engine in large plastic bag and tape closed at bottom of bag-place several moisture absorbing desiccant packs inside plastic bag
- Store engine inside a building (preferably climate controlled) to prevent corrosion.

To Remove Generator Set from Long-Term Storage:

1. Take off all protective coverings and unseal all the openings that were covered up.
2. Install batteries that are fully charged and connect the terminals.
3. Re-install the alternator belt if it had been removed.
4. Fill the fuel tank.
5. Perform all pre-start checks.
6. Crank the engine for 10 seconds with the starter, without letting the engine start. Wait 2 minutes and crank the engine an additional 10 seconds to make sure all bearing surfaces are well coated.
7. Start the engine and run at no load in a low idle for several minutes. Make sure the engine is warmed up and check gauges before going under load.
8. Check all gauges and check for leaks.

## Troubleshooting

### DC ELECTRICAL SYSTEM

PROBLEM	POSSIBLE CAUSE	RECOMMENDATION(S)
<b>Battery Will Not Charge</b>	Loose or corroded connections	<ul style="list-style-type: none"> <li>• Clean and tighten battery connections.</li> </ul>
	Sulfated or worn out batteries	<ul style="list-style-type: none"> <li>• Check specific gravity of each battery.</li> <li>• Check electrolyte level of each battery.</li> </ul>
	Loose or defective alternator belt	<ul style="list-style-type: none"> <li>• Adjust belt tension.</li> <li>• Replace belt.</li> </ul>
<b>Starter Inoperative</b>	Check DC circuit breaker	<ul style="list-style-type: none"> <li>• If the breaker is tripped, reset it.</li> </ul>
	Loose or corroded connections	<ul style="list-style-type: none"> <li>• Clean and tighten loose battery and harness plug connection.</li> </ul>
	Low battery condition	<ul style="list-style-type: none"> <li>• Check specific gravity of each battery.</li> <li>• Check electrolyte level of each battery.</li> </ul>
	Defective electrical system ground wire:	<ul style="list-style-type: none"> <li>• Repair or replace.</li> </ul>
<b>Starter Cranks Slowly</b>	Low battery condition	<ul style="list-style-type: none"> <li>• Battery is too small.</li> <li>• Battery cables are too small.</li> </ul>
	Check specific gravity of each battery	<ul style="list-style-type: none"> <li>• Replace battery if necessary.</li> </ul>
	Check electrolyte level of each battery	<ul style="list-style-type: none"> <li>• If low, fill cells with distilled water.</li> </ul>
	Crankcase oil too heavy	<ul style="list-style-type: none"> <li>• Fill with oil of appropriate viscosity.</li> </ul>
	Loose or corroded connections	<ul style="list-style-type: none"> <li>• Clean and tighten loose connections.</li> </ul>
<b>Entire Electrical System Does Not Function</b>	Check DC circuit breaker	<ul style="list-style-type: none"> <li>• If breaker is tripped, reset it.</li> </ul>
	Faulty connection	<ul style="list-style-type: none"> <li>• Clean and tighten battery and harness plug connections.</li> </ul>
	Sulfated or worn out batteries	<ul style="list-style-type: none"> <li>• Check specific gravity and electrolyte level of each battery.</li> </ul>

If you cannot correct problems with these procedures, see your **Northern Lights** dealer.

## Troubleshooting

### ENGINE

PROBLEM	POSSIBLE CAUSE	RECOMMENDATION(S)
<b>Engine Hard to Start or Will Not Start</b>	Improper starting procedure	<ul style="list-style-type: none"> <li>• See starting section of this manual. Take special note of Bypass Switch operation.</li> </ul>
	No fuel	<ul style="list-style-type: none"> <li>• Check level of fuel in fuel tank.</li> </ul>
	Low battery condition	<ul style="list-style-type: none"> <li>• Check electrolyte level and condition.</li> </ul>
	Excessive resistance in starting circuit	<ul style="list-style-type: none"> <li>• Clean and tighten all battery connections.</li> </ul>
	Crankcase oil too heavy	<ul style="list-style-type: none"> <li>• Use oil of proper viscosity.</li> </ul>
	Improper type of fuel	<ul style="list-style-type: none"> <li>• Consult fuel supplier and use proper type of fuel for operating condition.</li> </ul>
	Water, dirt or air in fuel system	<ul style="list-style-type: none"> <li>• Drain, flush, fill and bleed system.</li> </ul>
	Clogged primary fuel filter element	<ul style="list-style-type: none"> <li>• Clean or replace filter element.</li> </ul>
	Clogged secondary fuel filter element	<ul style="list-style-type: none"> <li>• Replace filter element.</li> </ul>
	Dirty or faulty injection nozzles	<ul style="list-style-type: none"> <li>• Have your dealer check injection nozzles.</li> </ul>
<b>Engine Runs Irregularly or Stalls Frequently</b>	Below normal engine temperature	<ul style="list-style-type: none"> <li>• Remove and check thermostat.</li> </ul>
	Clogged primary fuel filter element	<ul style="list-style-type: none"> <li>• Clean or replace filter element.</li> </ul>
	Clogged secondary fuel filter element	<ul style="list-style-type: none"> <li>• Replace secondary filter element.</li> </ul>
	Water or dirt in the fuel system	<ul style="list-style-type: none"> <li>• Drain, flush, fill and bleed system.</li> </ul>
	Dirty or faulty injection nozzles	<ul style="list-style-type: none"> <li>• Have your dealer check injection nozzles.</li> </ul>
	Air in fuel system	<ul style="list-style-type: none"> <li>• Inspect clamps and hoses on suction side of fuel pump for air leak.</li> </ul>
	Improper type of fuel	<ul style="list-style-type: none"> <li>• Consult fuel supplier and use proper type of fuel for operating condition.</li> </ul>
<b>Lack of Engine Power</b>	Engine overloaded	<ul style="list-style-type: none"> <li>• Reduce the load.</li> </ul>
	Intake air restriction	<ul style="list-style-type: none"> <li>• Service air cleaner.</li> </ul>
	Clogged primary fuel filter element	<ul style="list-style-type: none"> <li>• Clean or replace filter element.</li> </ul>
	Clogged secondary fuel filter element	<ul style="list-style-type: none"> <li>• Replace filter element.</li> </ul>
	Improper type of fuel	<ul style="list-style-type: none"> <li>• Consult fuel supplier and use proper type of fuel for operating conditions.</li> </ul>
	Overheated engine	<ul style="list-style-type: none"> <li>• See “Engine Overheats” in next category.</li> </ul>
	Below normal engine temperature	<ul style="list-style-type: none"> <li>• Remove and check thermostat.</li> </ul>
	Improper valve clearance	<ul style="list-style-type: none"> <li>• Reset valves. Best done by dealer.</li> </ul>
	Dirty or faulty injection nozzles	<ul style="list-style-type: none"> <li>• Replace injectors. Best done by dealer.</li> </ul>

## Troubleshooting

### ENGINE

PROBLEM	POSSIBLE CAUSE	RECOMMENDATION(S)
<b>Lack of Engine Power</b> <i>(continued)</i>	Low compression pressure (worn piston rings, etc...)	<ul style="list-style-type: none"> <li>• Consult dealer.</li> </ul>
<b>Engine Overheats</b>	Engine overloaded	<ul style="list-style-type: none"> <li>• Reduce the electrical load.</li> </ul>
	Low coolant level	<ul style="list-style-type: none"> <li>• Fill tank or radiator to proper level.</li> <li>• Check hoses for loose connections and leaks.</li> </ul>
	Keel cooling tubes (marine sets) have been painted	<ul style="list-style-type: none"> <li>• Remove paint from tubes.</li> </ul>
	Cooling system needs flushing	<ul style="list-style-type: none"> <li>• Flush cooling system.</li> </ul>
	Defective thermostat	<ul style="list-style-type: none"> <li>• Remove and check thermostat.</li> </ul>
	Defective temperature gauge	<ul style="list-style-type: none"> <li>• Check water temperature with thermometer and replace gauge if necessary.</li> </ul>
	Water pump impeller worn or broken	<ul style="list-style-type: none"> <li>• Check the impeller and replace if necessary.</li> </ul>
<b>Engine Knocks</b>	Insufficient oil	<ul style="list-style-type: none"> <li>• Call your dealer.</li> </ul>
	Injection pump out of time	<ul style="list-style-type: none"> <li>• Call your dealer.</li> </ul>
	Below normal engine temperature	<ul style="list-style-type: none"> <li>• Check your thermostats.</li> <li>• Check water temperature to see if temperature gauge is working properly.</li> </ul>
	Faulty fuel injector	<ul style="list-style-type: none"> <li>• Call your dealer.</li> </ul>
	Engine overheating	<ul style="list-style-type: none"> <li>• See "Engine Overheating" section.</li> </ul>
<b>High Fuel Consumption</b>	Improper type of fuel	<ul style="list-style-type: none"> <li>• Use correct fuel for temperature.</li> </ul>
	Clogged or dirty air cleaner	<ul style="list-style-type: none"> <li>• Service air cleaner.</li> </ul>
	Engine overloaded	<ul style="list-style-type: none"> <li>• Reduce the electrical load.</li> </ul>
	Improper valve clearance	<ul style="list-style-type: none"> <li>• See your dealer.</li> </ul>
	Injection nozzles dirty	<ul style="list-style-type: none"> <li>• See your dealer.</li> </ul>
	Injection pump out of time	<ul style="list-style-type: none"> <li>• See your dealer.</li> </ul>
	Engine not at proper temperature	<ul style="list-style-type: none"> <li>• Check your thermostats.</li> <li>• Check water temperature with thermometer and replace gauge if necessary.</li> </ul>
<b>Below Normal Engine Temperature</b>	Thermostats not working properly	<ul style="list-style-type: none"> <li>• Check thermostats.</li> </ul>
	Temperature gauge not working properly	<ul style="list-style-type: none"> <li>• Check water temperature with thermometer.</li> </ul>
<b>Low Oil Pressure</b>	Low oil level	<ul style="list-style-type: none"> <li>• Fill crankcase to proper level.</li> </ul>
	Improper type of oil	<ul style="list-style-type: none"> <li>• Drain and fill crankcase with correct oil.</li> </ul>
	Partially plugged oil filter	<ul style="list-style-type: none"> <li>• Replace filter.</li> </ul>

If you cannot correct problems with these procedures, see your **Northern Lights** dealer.

## Troubleshooting

### ENGINE

PROBLEM	POSSIBLE CAUSE	RECOMMENDATION(S)
<b>High Oil Consumption</b>	Break-in period	• Oil consumption decreases after break in.
	Crankcase oil too light	• Use proper viscosity oil.
	Oil leaks	• Check for leaks in lines around gaskets and drain plug.
	Crankcase over full	• Remove excess oil.
<b>Engine Emits Black or Gray Exhaust Smoke</b>	Clogged or dirty air cleaner	• Service air cleaner.
	Defective muffler (back pressure too high)	• Have dealer check back pressure.
	Improper fuel	• Use correct fuel for temperature.
	Fuel pump faulty	• See your dealer.
	Injection nozzles dirty	• See your dealer.
	Engine overloaded	• Reduce the electrical load.
	Injection nozzles dirty	• See your dealer.
	Injection pump faulty	• Consult your dealer.
	Engine out of time	• See your dealer.
	Incorrect valve clearance	• Consult your dealer.
<b>Engine Emits White Smoke</b>	Improper fuel	• Use correct fuel for temperature.
	Cold engine	• Warm up engine to normal operating temperature.
	Defective thermostat	• Remove and check thermostat.
	Engine out of time	• See your dealer.
	Low Compression Pressure	• See your dealer.
	Low engine oil viscosity	• Use proper viscosity of oil to ambient temperature.
	Excessive amount of engine oil	• Maintain correct oil level.
	Fuel injection nozzles faulty (uneven injection)	• See your dealer.

# AC Wiring Diagram

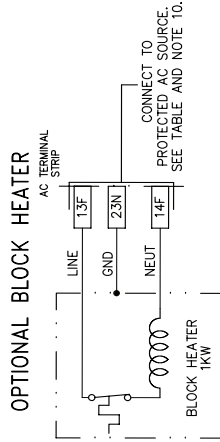
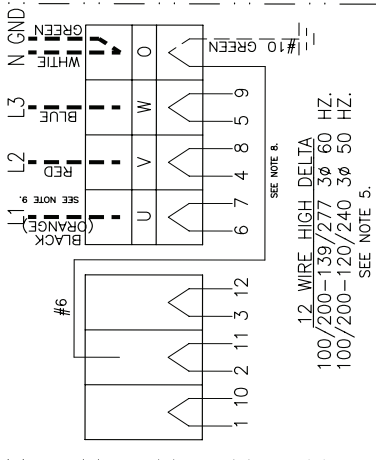
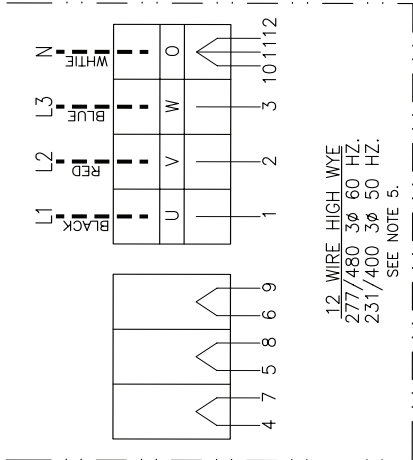
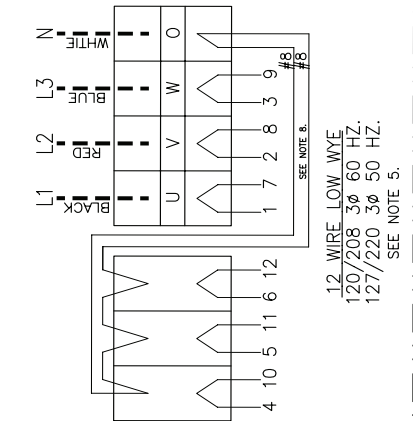
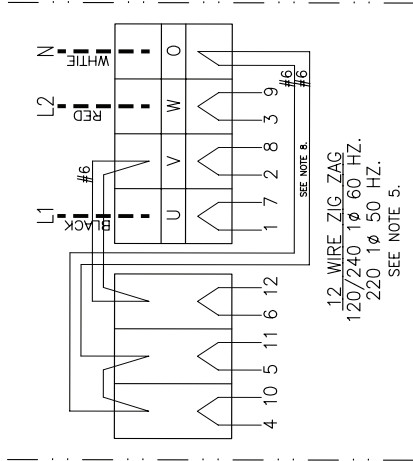

HEATER SPEC	VOLTAGE	CURRENT
120 VAC	100-120 VAC	9 A
240 VAC	200-240 VAC	5 A

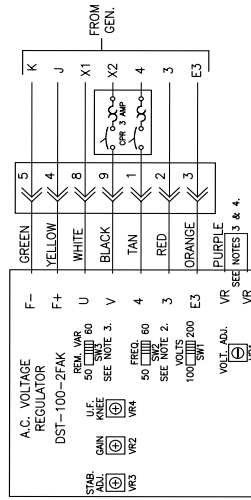

**NOTES:**

- ALL N.L.I. INSTALLED CONDUCTORS ARE TO BE TYPE MTW, 105°C, STRANDED, 600VAC.
- SET SW2 FOR CURRENT APPLICATION. (50 OR 60 HZ)
- SET SW3 PER APPLICATION IF REMOTE VOLTAGE ADJUST RHEOSTAT IS USED.
- FOR REMOTE VOLTAGE ADJUST RHEOSTAT CUT JUMPER AND SPLICE INTO PURPLE LEADS.
- DELETE NEUTRAL CONDUCTOR (AND JUMPER IF PRESENT), IF LOWER VOLTAGE IS NOT REQUIRED.
- MARINE GENSETS ARE GROUNDED BY CUSTOMER, AT CUSTOMER'S DISCRETION.
- THICK HIDDEN (DASHED) LINES INDICATE CUSTOMER SUPPLIED AND CONNECTED MAIN OUTPUT CONDUCTORS. SIZING TO BE DETERMINED PER INSTALLATION.
- NEUTRAL CONDUCTORS SIZED FOR 38KW UNITS AT THE LOWEST LISTED VOLTAGE. CONSULT NLI ENGINEERING FOR CONDUCTOR SIZING AT OTHER GENSET VOLTAGE/KW RATINGS.
- LINE ONE (HIGH LEG) TO BE MARKED ORANGE WHEN NEUTRAL IS PRESENT, IN ACCORDANCE WITH ARTICLE 215-8 OF THE NATIONAL ELECTRIC CODE.

Northern Lights AC Wiring Diagram –  
DST-100-2FAK Voltage Regulator  
Drawing B-9582F

*Drawings subject to change without notice.*

## AC Wiring Diagram

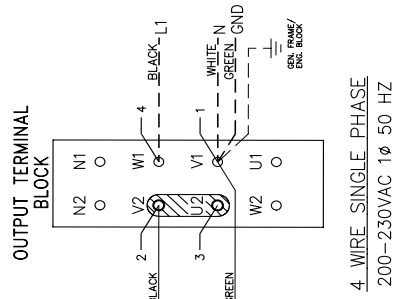
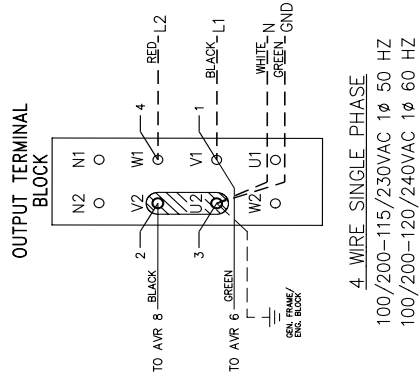
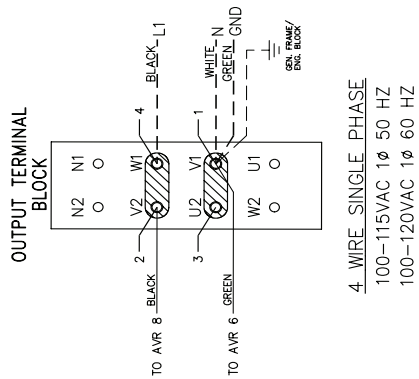

4 WIRE SINGLE PHASE  
200-230VAC 1Ø 50 HZ



INDICATES LINK BAR USED.

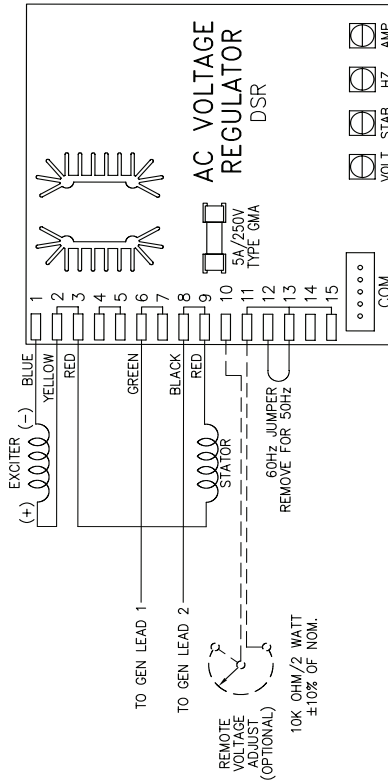

### OPTIONAL BLOCK HEATER

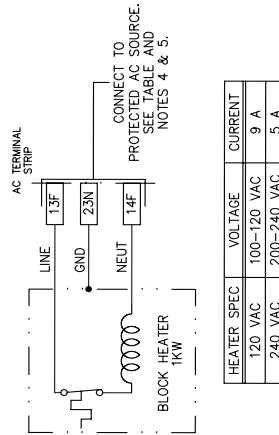

### OPTIONAL GENERATOR SPACE HEATER

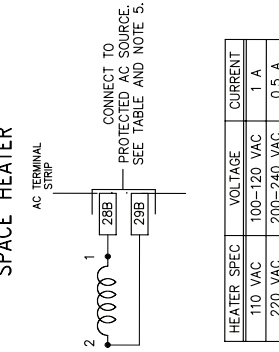

### NOTES:

- ALL INSTALLATION CONDUCTORS ARE TO BE AWG 14, TYPE MTW, 105°C, 600VAC, STRANDED, EXCEPT AS NOTED.
- MARINE GENSETS ARE TO BE GROUNDED BY CUSTOMER ONLY. AT CUSTOMER'S DISCRETION. INDUSTRIAL GENSETS TO BE GROUNDED IN ACCORDANCE WITH THE NATIONAL ELECTRICAL CODE AND ANY APPLICABLE LOCAL CODES.
- DASHED LINES INDICATE CUSTOMER SUPPLIED AND CONNECTED MAIN OUTPUT CONDUCTORS. SIZING DETERMINED PER INSTALLATION.
- REMOVE THREE-POLE PLUG AND WIRE BLOCK HEATER LEADS TO TERMINALS NUMBERED AS INDICATED FOR MARINE DUTY UNITS ONLY.
- DO NOT ENERGIZE HEATER WHEN UNIT IS IN OPERATION.

Northern Lights AC Wiring Diagram –  
M40C3 single phase DSR regulator  
Drawing B-10606

Drawings subject to change without notice.

# AC Wiring Diagram

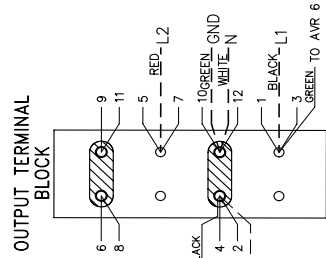

12 WIRE HIGH WYE 3φ  
220/380VAC - 254/440VAC 50 HZ  
240/416VAC - 277/480VAC 60 HZ

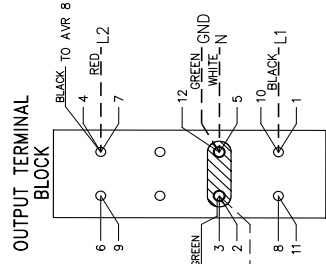

12 WIRE SERIES DELTA 3φ  
110/220VAC 50 HZ  
120/240VAC 60 HZ

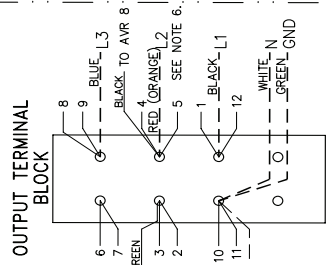

12 WIRE DOUBLE DELTA 1φ  
110/220VAC 50 HZ  
120/240VAC 60 HZ

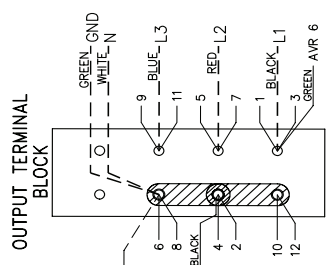

12 WIRE LOW WYE 3φ  
110/190VAC - 127/220VAC 50 HZ  
120/208VAC - 139/240VAC 60 HZ

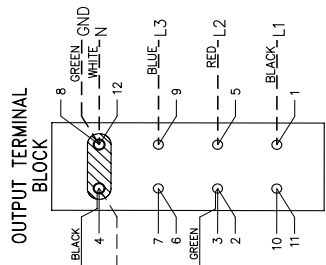

12 WIRE ZIG ZAG 1φ  
110/220VAC 50 HZ  
120/240VAC 60 HZ

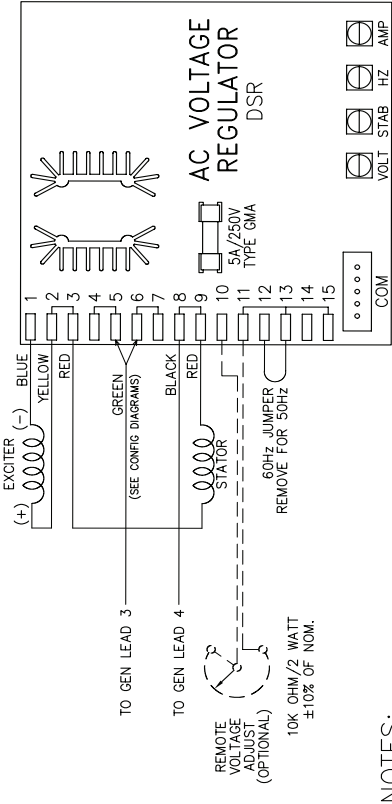

**NOTES:**

1. ALL INSTALLATION CONDUCTORS ARE TO BE AWG 14, TYPE MTW, 105°C, 600VAC, STRANDED, EXCEPT AS NOTED.
2. CUSTOMER'S DISCRETION. INDUSTRIAL GENSETS TO BE GROUNDED IN ACCORDANCE WITH THE NATIONAL ELECTRICAL CODE AND ANY APPLICABLE LOCAL CODES.
3. DELETE NEUTRAL CONNECTION IF L-N VOLTAGE IS NOT REQUIRED.
4. CONNECT GREEN SENSE LEAD FROM GENERATOR LEAD 3 TO AVR TERMINAL 5 OR 6 PER INDIVIDUAL CONFIGURATION DIAGRAMS.
5. MAIN OUTPUT CONDUCTORS. SIZING DETERMINED PER INSTALLATION.
6. HIGH LEG IS TO BE MARKED ORANGE WHEREVER NEUTRAL IS PRESENT, IN ACCORDANCE WITH ARTICLE 215-8 OF THE NATIONAL ELECTRICAL CODE.
7. REMOVE THREE-POLE PLUG AND WIRE BLOCK HEATER LEADS TO TERMINALS NUMBERED AS INDICATED FOR MARINE DUTY UNITS ONLY.

**OPTIONAL BLOCK HEATER**

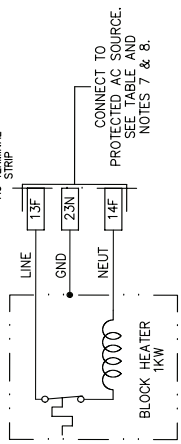

HEATER SPEC	VOLTAGE	CURRENT
120 VAC	100-120 VAC	9 A
240 VAC	200-240 VAC	5 A

**OPTIONAL GENERATOR SPACE HEATER**

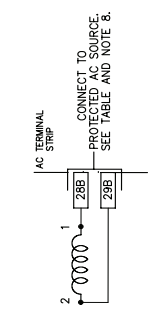

HEATER SPEC	VOLTAGE	CURRENT
110 VAC	100-120 VAC	1 A
220 VAC	200-240 VAC	0.5 A



INDICATES LINK BAR USED.

Northern Lights AC Wiring Diagram - M40C3 three phase DSR regulator Drawing B-10539

Drawings subject to change without notice.



# DC Wiring Diagram

- NOTES:**
1. ALL INSTALLATION CONDUCTORS ARE TO BE AWG 14, TYPE MTW, 600VAC, 105°C, MULTISTRAND, EXCEPT THE ENGINE HARNESS, TWISTED PAIRS AND AS NOTED.
  2. ALL CONDUCTORS, INCLUDING TWISTED PAIRS, MUST BE IDENTIFIED BY WIRE MARKER AT EACH CONNECTION POINT.
  3. WITH WAGNET PANELS, THE WIRE IDENTIFICATION LABEL (SIR) AS SHOWN WHEN USING A 50 HZ OVERSPEED SWITCH TRIP.....1695 RPM (3446 HZ) MUST BE IDENTIFIED TO THE WAGNET PANELS.
  4. 50 HZ OVERSPEED SWITCH TRIP.....1695 RPM (3446 HZ) MUST BE IDENTIFIED TO THE WAGNET PANELS.
  5. 50 HZ OVERSPEED SWITCH TRIP.....1695 RPM (3446 HZ) MUST BE IDENTIFIED TO THE WAGNET PANELS.
  6. IF TWO GAUGED CONTROL PANELS ARE USED, DUAL STATION WIRE IDENTIFICATION LABELS MUST BE USED.
  7. WIRE OPTIONAL 24V PTO CLUTCH TO TERMINAL STRIP IN J-BOX.

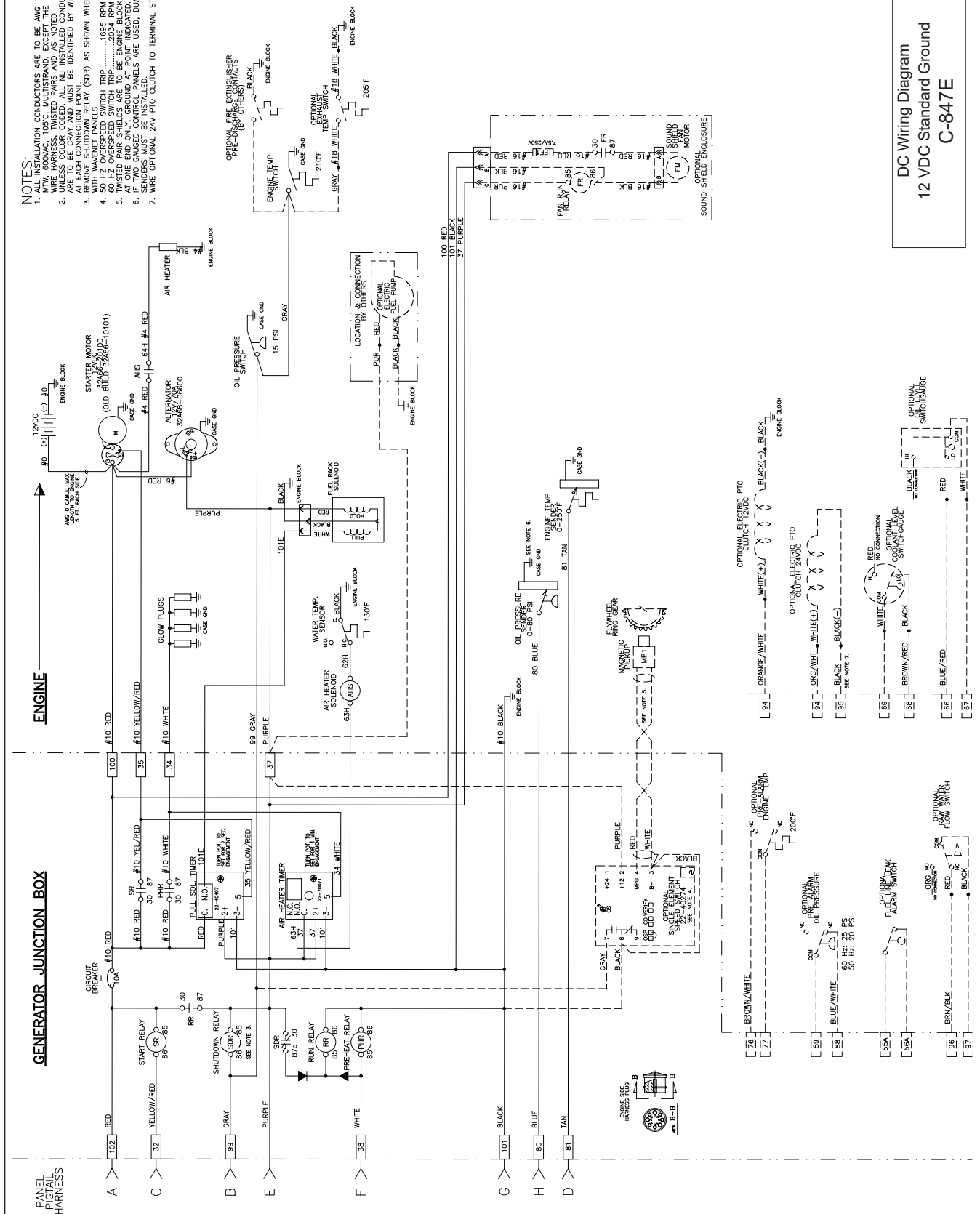

DC Wiring Diagram  
12 VDC Standard Ground  
C-847E

Drawings subject to change without notice.

# DC Wiring Diagram

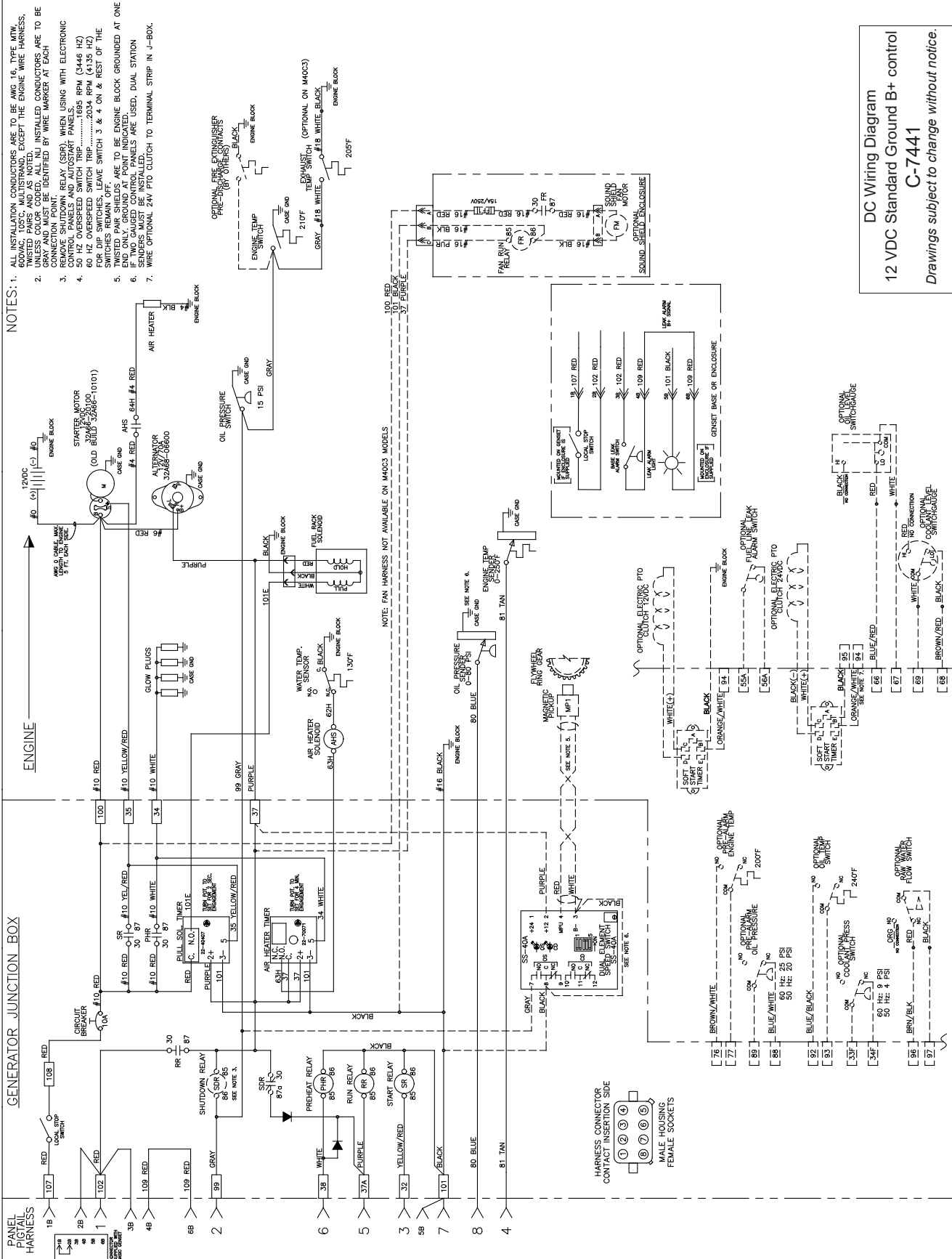

- NOTES:**
1. ALL INSTALLATION CONDUCTORS ARE TO BE AWG. 16 TYPE UTV, TWISTED PAIRS AND AS NOTED. INSTALLED CONDUCTORS ARE TO BE GRAY AND MUST BE IDENTIFIED BY WIRE MARKER AT EACH CONNECTION POINT.
  2. REMOVE SHUTDOWN RELAY (SDR) WHEN USING WITH ELECTRONIC SWITCHES REMAINING.
  3. 50 HZ OVERSPEED SWITCH TRIP.....2034 RPM (4135 HZ)
  4. FOR DIP SWITCHES, LEAVE SWITCH 3 & 4 ON & REST OF THE SWITCHES REMAIN OFF.
  5. SWITCHES REMAINING ARE TO BE ENGINE BLOCK GROUNDED AT ONE END ONLY. GROUND AT POINT INDICATED.
  6. IF TWO GAUGED CONTROL PANELS ARE USED, DUAL STATION WIRE OPTIONAL 24V PTO CLUTCH TO TERMINAL STRIP IN J-BOX.
  7. WIRE OPTIONAL 24V PTO CLUTCH TO TERMINAL STRIP IN J-BOX.

DC Wiring Diagram  
 12 VDC Standard Ground B+ control  
 C-7441  
 Drawings subject to change without notice.

# DC Wiring Diagram

- NOTES:**
1. ALL INSTALLATION CONDUCTORS ARE TO BE AWG 14, TYPE MTW, 600VAC, 105°C, MULTI-STRAND, EXCEPT THE ENGINE WIRELESS COILS, WIRELESS TAPERS AND WIRELESS CONDUCTORS ARE TO BE GRAY AND MUST BE IDENTIFIED BY WIRE MARKER AT EACH CONNECTION POINT.
  2. WITH WAVENET PANELS.
  3. 50 HZ OVERSPEED SWITCH TRIP.....1695 RPM (3448 HZ)
  4. TWISTED PAIR SHIELDS ARE TO BE ENGINE BLOCK GROUNDED AT ONE END ONLY. GROUND AT POINT INDICATED.
  5. TWISTED PAIR SHIELDS ARE TO BE ENGINE BLOCK GROUNDED AT ONE END ONLY. GROUND AT POINT INDICATED.
  6. WIRELESS COILS AND WIRELESS TAPERS ARE USED, DUAL STATION SENDERS MUST BE INSTALLED.

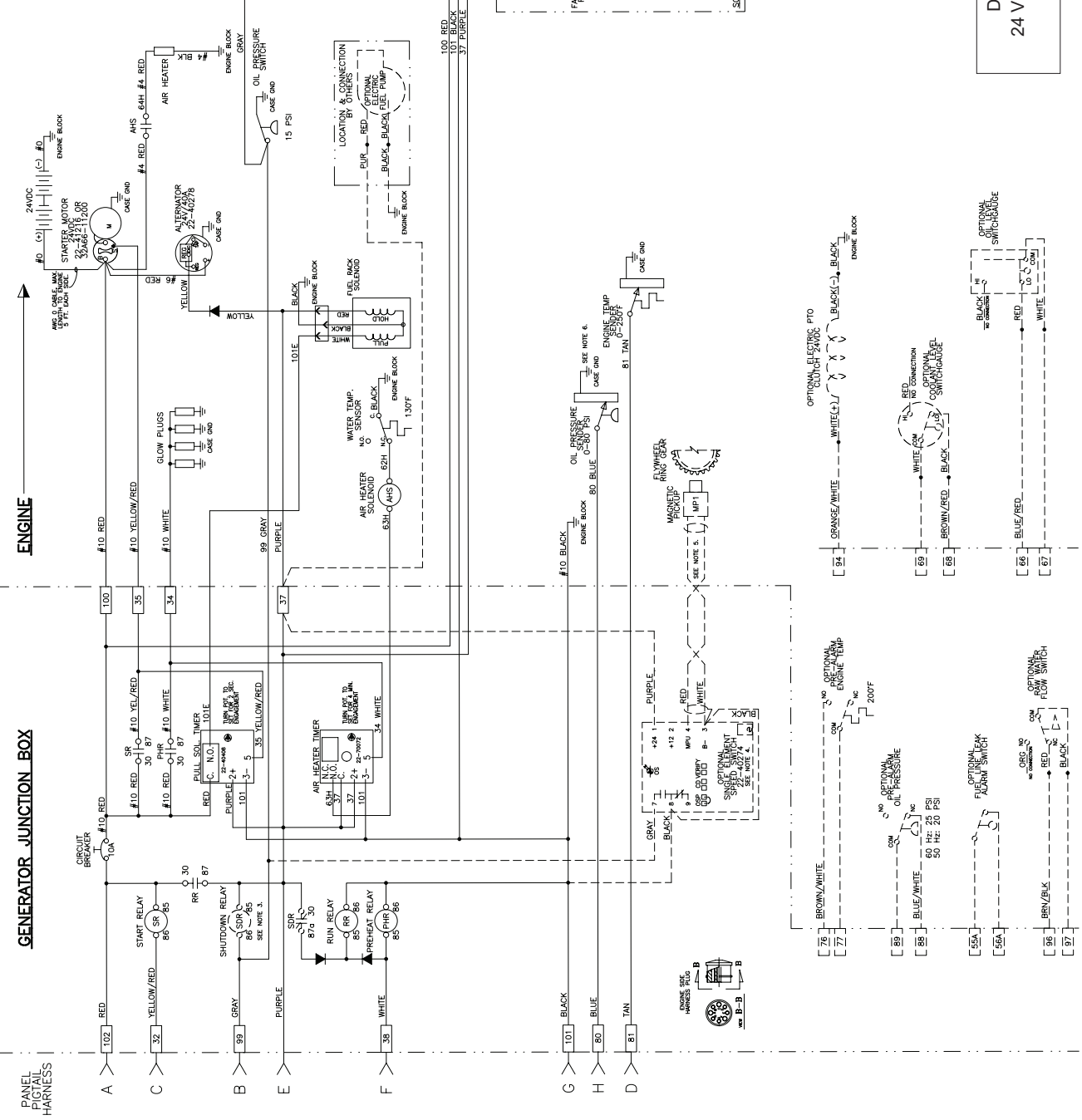

DC Wiring Diagram  
24 VDC Standard Ground  
C-891C

Drawings subject to change without notice.

# DC Wiring Diagram

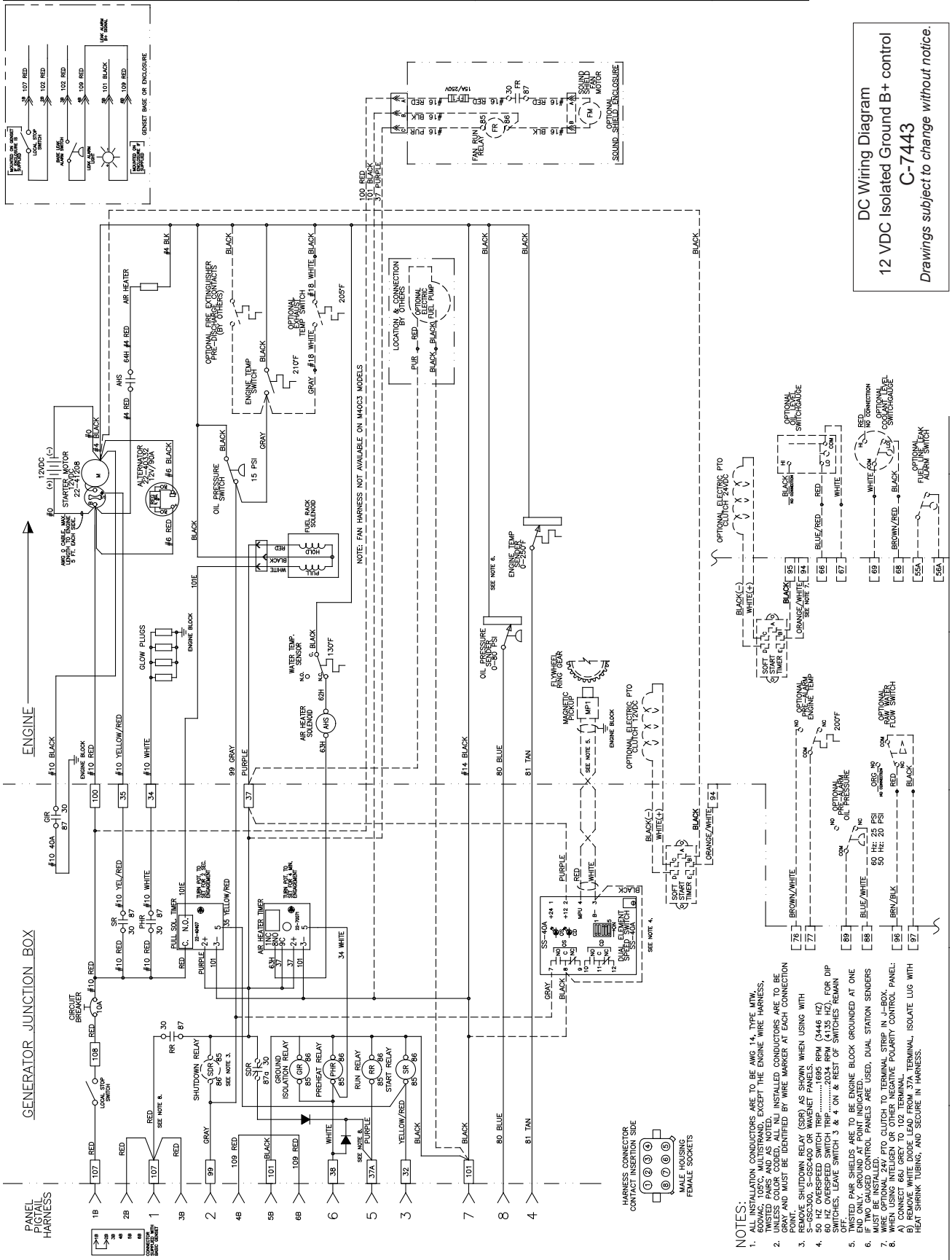

DC Wiring Diagram  
 12 VDC Isolated Ground B+ control  
 C-7443  
 Drawings subject to change without notice.

- NOTES:**
1. WIRE TERMINAL CONDUITS ARE TO BE AWG. 14, TYPE ALTY, 600V, 105°C MULTISTRAND EXCEPT THE ENGINE WIRE HARNESS, UNLESS COLOR CODED, ALL IN INSTALLED CONDUCTORS ARE TO BE IDENTIFIED BY WIRE MARKER AT EACH CONNECTION POINT.
  2. REMOVE SHUTDOWN RELAY (SR) AS SHOWN WHEN USING WITH 50 HZ OVERSPEED SWITCH TRIP .....2034 RPM (4135 HZ), FOR DIP SWITCHES, LEAVE SWITCH 3 & 4 ON & REST OF SWITCHES REMAIN SWITCHED.
  3. SWITCH PAIR SHIELDS ARE TO BE ENGINE BLOCK GROUNDED AT ONE END ONLY, GROUND AT POINT INDICATED.
  4. WIRE OPTIONAL 24V PTO CLUTCH TO TERMINAL STRIP IN J-BOX. AT CONNECTION POINTS OR OTHER NEGATIVE POLARITY CONTROL PANEL.
  5. REMOVE WHITE DIODE LEAD FROM 37A TERMINAL, SOLDATE LUG WITH HEAT SHRINK TUBING, AND SECURE IN HARNESS.

# DC Wiring Diagram

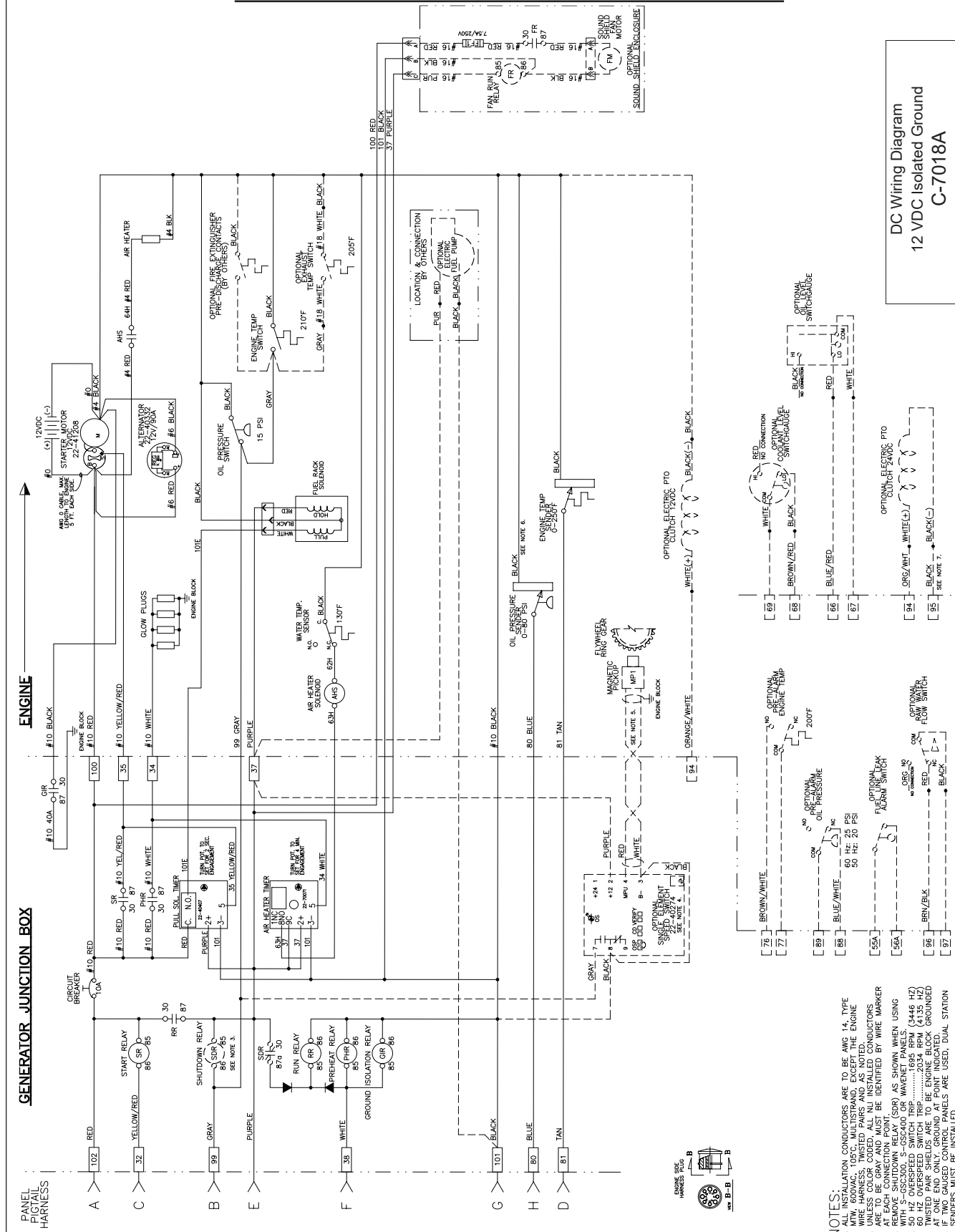

- NOTES:**
1. ALL INSTALLATION CONDUCTORS ARE TO BE AWG 14, TYPE THHN UNLESS OTHERWISE NOTED. ALL WIRING TO BE DONE IN ACCORDANCE WITH THE ENGINE WIRE HARNESS, TWISTED PAIRS AND AS NOTED.
  2. UNLESS COLOR CODED, ALL NU INSTALLED CONDUCTORS ARE TO BE IDENTIFIED BY WIRE MARKER. ALL CONDUCTORS MUST BE IDENTIFIED BY WIRE MARKER AT EACH CONNECTION POINT.
  3. REMOVE SHUTDOWN RELAY (SOR) AS SHOWN WHEN USING WITH S-GSC300, S-GSC400 OR WAVELET PANELS.
  4. 60 HZ OVERSPEED SWITCH TRIP POINT ..... 2034 RPM (4135 HZ)
  5. TWISTED PAIR SHIELDS ARE TO BE ENGINE BLOCK GROUNDED AT ONE END ONLY, GROUND AT POINT INDICATED.
  6. ALL ELECTRICAL RELAYS ARE USED, DUAL STATION SENDERS MUST BE INSTALLED.
  7. WIRE OPTIONAL 24V PTO CLUTCH TO TERMINAL STRIP IN J-BOX.

# DC Wiring Diagram

- NOTES:**
1. ALL INSTALLATION CONDUCTORS ARE TO BE AWG 16, TYPE MTW, 600VAC, 105°C, MULTISTRAND, EXCEPT THE ENGINE WIRE HARNESS, TWISTED PAIRS AND AS NOTED. INSTALLED CONDUCTORS ARE TO BE GRAY AND MUST BE IDENTIFIED BY WIRE MARKER AT EACH CONNECTION POINT.
  2. CONTROL PANELS AND AUTOSTART PANELS:
  3. CONNECTION POINT: RELAY (SR) MUST BE USING WITH ELECTRONIC CONTROL PANELS AND AUTOSTART PANELS.
  4. 50 HZ OVERSPEED SWITCH TRIP .....1695 RPM (3446 HZ) FOR DIP SWITCHES, LEAVE SWITCH 3 & 4 ON & REST OF THE SWITCHES OFF.
  5. TWISTED PAIR SHIELDS ARE TO BE ENGINE BLOCK GROUNDED AT ONE END ONLY. GROUND AT POINT INDICATED.
  6. TWISTED PAIR SHIELDS ARE TO BE ENGINE BLOCK GROUNDED AT ONE END ONLY. GROUND AT POINT INDICATED.
  7. WIRE OPTIONAL 24V PTO CLUTCH TO TERMINAL STRIP IN J-BOX.

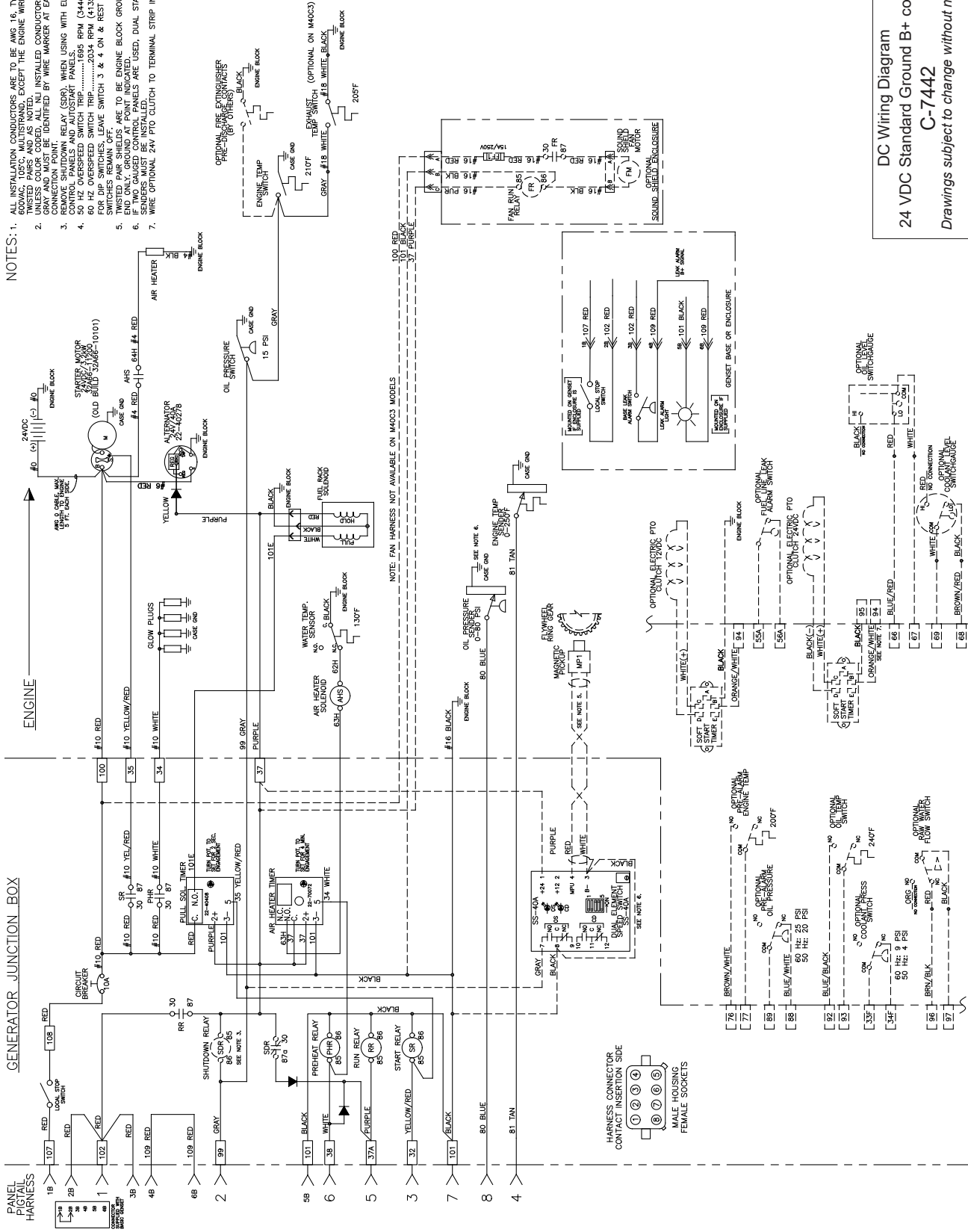

DC Wiring Diagram  
 24 VDC Standard Ground B+ control  
 C-7442  
 Drawings subject to change without notice.

# DC Wiring Diagram

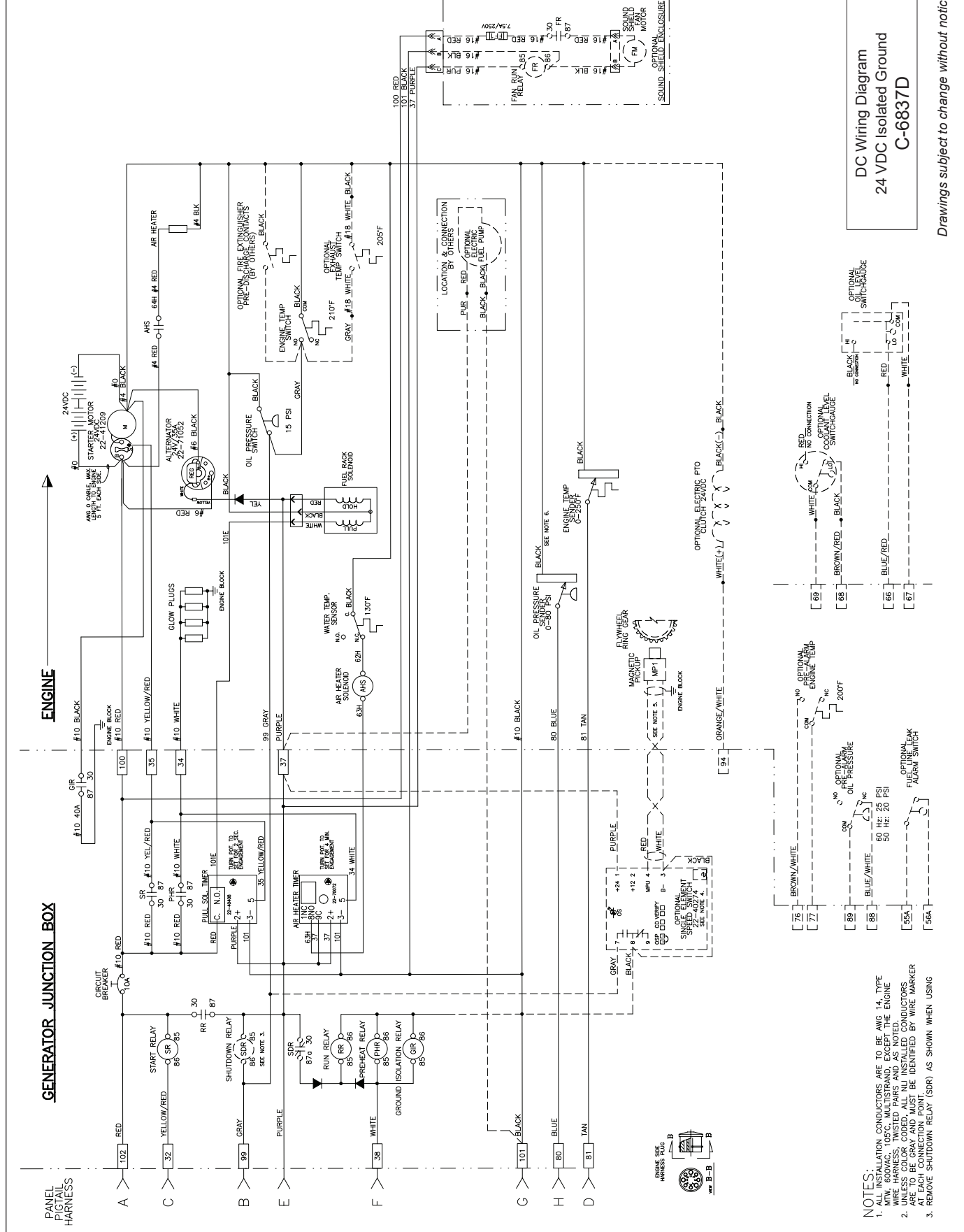

DC Wiring Diagram  
24 VDC Isolated Ground  
C-6637D

Drawings subject to change without notice.

# DC Wiring Diagram

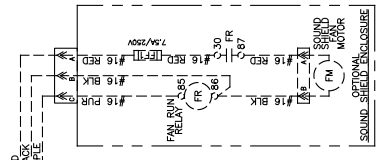
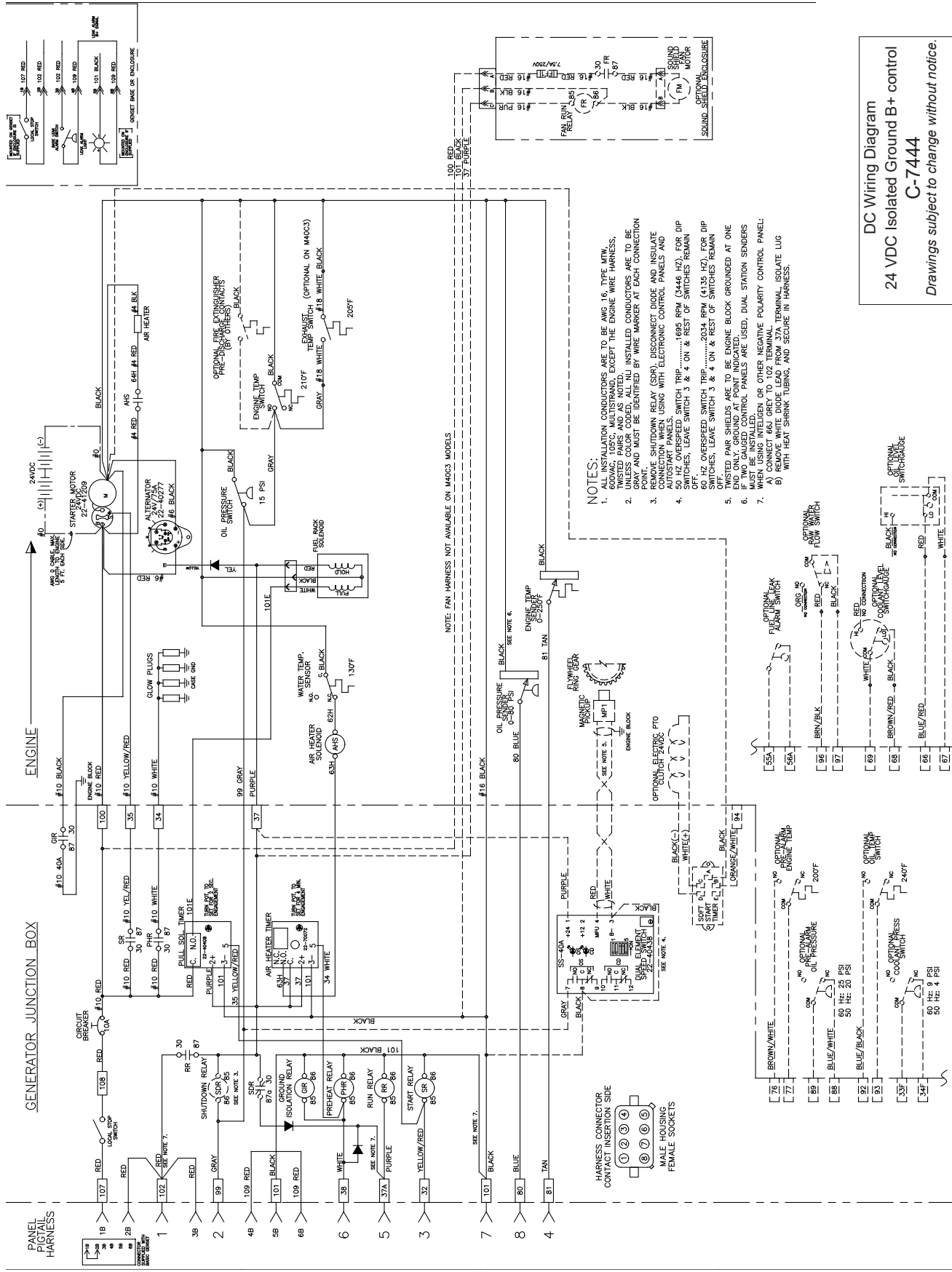

- NOTES:**
1. ALL INSTALLATION CONDUCTORS ARE TO BE AWG. 16, TYPE MTW, 60VAC, 105°C, MULTISTRAND, EXCEPT THE ENGINE WIRE HARNESS, WHICH IS AWG. 18, TYPE MTW, 60VAC, 105°C, MULTISTRAND.
  2. TWISTED PAIRS AND AS NOTED, INSTALLED, CONDUCTORS ARE TO BE IDENTIFIED BY WIRE MARKER AT EACH CONNECTION POINT.
  3. SHUTDOWN RELAY (SR), DISCONNECT BODE AND INSULATE CONNECTION WHEN USING WITH ELECTRONIC CONTROL PANELS AND AUTOSTART PANELS.
  4. 50 HZ OVERSPEED SWITCH TRIP.....1695 RPM (3446 HZ), FOR DIP SWITCHES, LEAVE SWITCH 3 & 4 ON & REST OF SWITCHES REMAIN OFF.
  5. 60 HZ OVERSPEED SWITCH TRIP.....2034 RPM (4135 HZ), FOR DIP SWITCHES, LEAVE SWITCH 3 & 4 ON & REST OF SWITCHES REMAIN OFF.
  6. TWISTED PAIR SHIELDS ARE TO BE ENGINE BLOCK GROUNDED AT ONE END ONLY, GROUND AT POINT INDICATED.
  7. WHEN USING INTELIJEN OR OTHER NEGATIVE POLARITY CONTROL PANEL:
    - A) CONNECT WIRE TO NEGATIVE TERMINAL, ISOLATE LUG WITH HEAT SHRINK TUBING, AND SECURE IN HARNESS.
    - B) WITH HEAT SHRINK TUBING, AND SECURE IN HARNESS.

DC Wiring Diagram  
 24 VDC Isolated Ground B+ control  
 C-7444  
 Drawings subject to change without notice.



## S-1B Wiring Diagram

### CONTROL PANEL

V	P/N
12	22-92120
12	22-95905
24	22-92125

V	P/N
12	22-90013
24	22-90016

TERMINAL STRIP

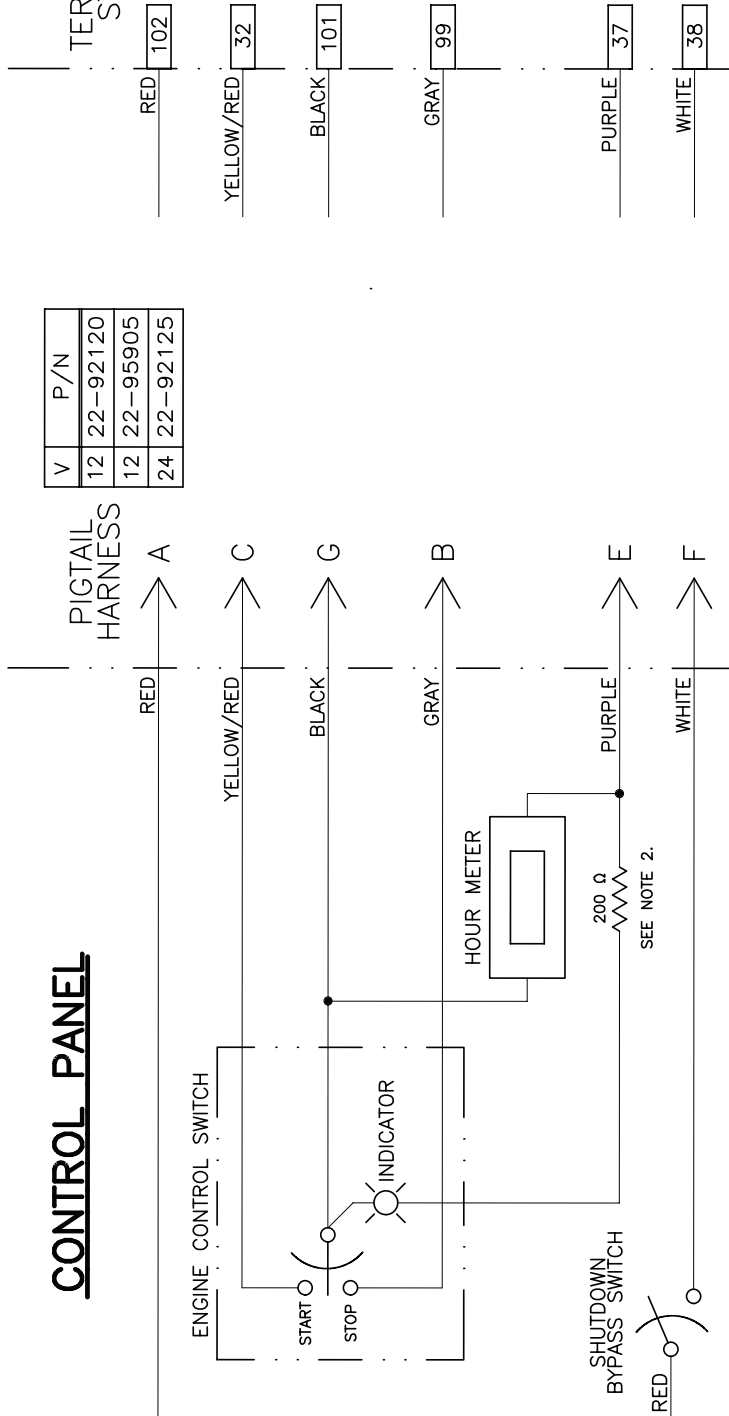

### NOTES:

1. ALL INSTALLATION CONDUCTORS ARE TO BE AWG 14, TYPE MTW, 600VAC, 105°C, STRANDED, EXCEPT AS NOTED.
2. RESISTOR USED ON 24V UNITS ONLY.
3. COMBINES AND REPLACES DRAWINGS A-3170, A-4792, A-6650, AND A-4134.

S-1B Panel  
A-12667A

*Drawings subject to change without notice.*

### S-3 Wiring Diagram

## CONTROL PANEL

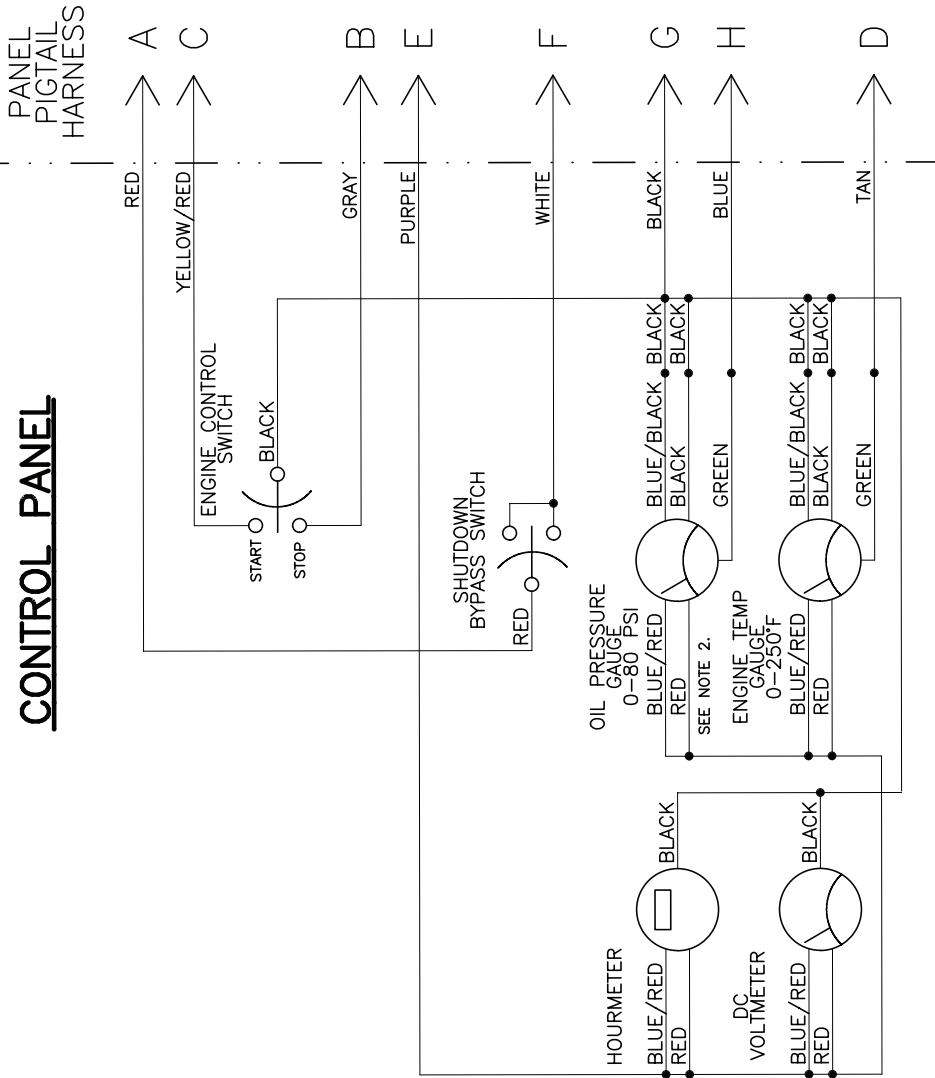

P/N'S
22-91216
22-91217
22-98708
22-98709
22-95916

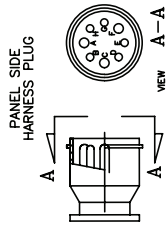

#### NOTES:

1. ALL INSTALLATION CONDUCTORS ARE TO BE AWG 14, TYPE MTW, 600VAC, 105°C, STRANDED, EXCEPT AS NOTED.
2. OIL PRESSURE GAUGE IS TO BE 0-150 PSI ON PANELS 22-98708 & 22-98709.

S-3 Panel  
A12645B

*Drawings subject to change without notice.*





4420 14th Ave. NW., Seattle WA 98107

Tel: (206) 789-3880 • 1-800-762-0165 • [www.northern-lights.com](http://www.northern-lights.com)

Northern Lights and Lugger are registered trademarks of Northern Lights, Inc.

© 2020 All rights reserved. Litho USA.