

# OPERATOR'S MANUAL

Publication #0NL382 for Model:

**NL382W**



**NORTHERN LIGHTS**  
®



— CALIFORNIA —  
**Proposition 65 Warning:**

*Diesel engine exhaust and some of its constituents  
are known to the State of California to cause  
cancer, birth defects, and other reproductive harm.*



**Northern Lights**  
4420 14th Avenue N.W.  
Seattle, WA 98107  
Tel: (206) 789-3880  
Fax: (206) 782-5455

Copyright ©2005 Alaska Diesel Electric, Inc.  
All rights reserved. Northern Lights™, and  
the Northern Lights logo are trademarks of  
Alaska Diesel Electric, Inc.

Printed in U.S.A.  
PART NO.: ONL382 08/05

# OPERATOR'S MANUAL

for Model  
NL382W

*Read this operator's manual thoroughly before starting to operate your equipment.  
This manual contains information you will need to run and service your new unit.*

## Table of Contents

<b>INTRODUCTION</b> .....	2	V-Belts .....	12
Model Included .....	2	Retightening Cylinder Head Bolts .....	12
Model Number .....	2	Valve Clearances .....	12
Serial Numbers .....	2	Fuels - General .....	13
<b>WARRANTY</b> .....	3	Fuel Filters .....	13
<b>SAFETY RULES</b> .....	3	Bleeding the Fuel System .....	14
<b>COMPONENT LOCATION</b>		Injector Service .....	14 - 15
Industrial Generator .....	4	Injection Pump .....	15
<b>CONTROL PANELS</b>		Cooling System - General .....	15
Northern Lights Generator Sets .....	5 - 6	Checking Coolant Level .....	15
<b>OPERATING PROCEDURES</b>		Cooling System Flushing .....	15
Break-in Period .....	7	Clean Radiator .....	15
Before Starting .....	7	Generator Ends .....	16
Starting .....	7	D.C. Electrical System - General .....	16
Operating .....	7	Booster Batteries .....	16
Stopping .....	7	Battery Care .....	16
Shutdowns and Alarms .....	8	Winterizing / Out-of-Service .....	16
Spare Parts .....	8	<b>TROUBLESHOOTING</b>	
<b>SERVICING SCHEDULE CHART</b> .....	9 - 10	Electrical .....	17
<b>SERVICING</b>		Engine .....	18 - 20
Lubrication - General .....	11	<b>WIRING DIAGRAMS</b>	
Checking Oil .....	11	AC Electrical .....	21
Oil Changes .....	11	DC Electrical .....	22
Changing Oil Filter .....	11		
Air Filter .....	11		

### Proprietary Information

This publication is the property of Alaska Diesel Electric, Inc.  
It may not be reproduced in whole or in part without the written permission of Alaska Diesel Electric, Inc.  
© Alaska Diesel Electric, Inc. All rights reserved. Litho U.S.A. Publication number ONL382 08/05

## Introduction

The servicing of generator sets presents unique problems. In many cases, the generator sets cannot be moved to a repair facility. Failures often occur in remote areas far from competent assistance; therefore, maintenance schedules must be adhered to more strictly. Failures begin with minor problems that are overlooked and become amplified when not corrected during routine maintenance.

As operator, it is your obligation to learn about your equipment and its proper maintenance. This is not a comprehensive technical service manual. Nor will it make the reader into an expert mechanic. Its aim is to aid you in maintaining your unit properly.

## Unit Identification

### MODELS INCLUDED

This manual covers the operating instructions for:  
**NL382W** industrial generator sets.

## Model Numbers

Model numbers give the unit's application, block model, aspiration, and RPM:

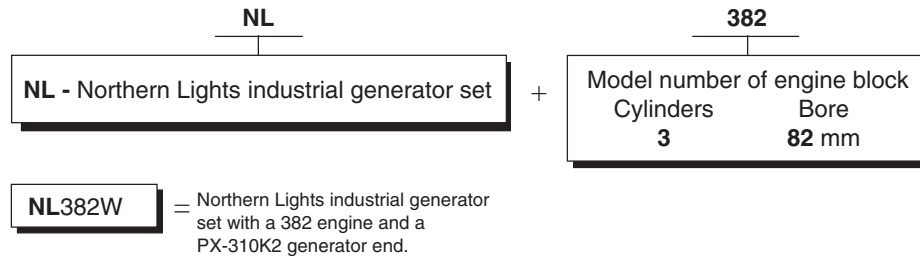

## Serial Numbers

**NORTHERN LIGHTS**

**Generator Set Data**

Set Serial #

Set Model #

**AC Generator Data**

Model #

Serial #

DUTY	<input style="width: 50%;" type="text"/>	WIRE	<input style="width: 50%;" type="text"/>
KW	<input style="width: 50%;" type="text"/>	INSUL	<input style="width: 50%;" type="text"/>
KVA	<input style="width: 50%;" type="text"/>	AMB °C	<input style="width: 50%;" type="text"/>
RPM	<input style="width: 50%;" type="text"/>	PF	<input style="width: 50%;" type="text"/>
HERTZ	<input style="width: 50%;" type="text"/>	VOLTS	<input style="width: 50%;" type="text"/>
PHASE	<input style="width: 50%;" type="text"/>	VOLTS	<input style="width: 50%;" type="text"/>
°C RISE	<input style="width: 50%;" type="text"/>	AMPS	<input style="width: 50%;" type="text"/>
RULE	<input style="width: 50%;" type="text"/>	AMPS	<input style="width: 50%;" type="text"/>

Alaska Diesel Electric, Inc. • Seattle, WA U.S.A.  
[www.northern-lights.com](http://www.northern-lights.com)      00-4002-1-1

Your set has three serial numbers: ① an engine number stamped on a plate attached to the valve cover, ② a generator end serial number, and ③ a generator set serial number.

**NOTE:** Always use the generator set serial number when ordering parts or in correspondence. The generator set serial number plate is found on the service side of the generator and resembles the drawing in Figure 1.

Figure 1: Generator set serial number plate.

A warranty registration certificate is supplied with your set. It entitles the original purchaser of our equipment to a warranty covering material or assembly faults. The extent of coverage is described in the Limited Warranty Statement. We recommend that you study the statement carefully.

**NOTE:** If the warranty is to apply, the servicing instructions outlined in this manual must be followed. If further information is needed, please contact an authorized dealer or the factory.



**CAUTION:** *Accident reports show that careless use of engines causes a high percentage of accidents.*

*You can avoid accidents by observing these safety rules. Study these rules carefully and enforce them on the job.*

- Never leave engine without proper security.
- Turn the coolant tank cap slowly to relieve pressure before removing. Add coolant only when the engine is stopped and cool.
- Mount a fire extinguisher near engine.
- Always disconnect the battery ground strap before making adjustments.
- Operate engines in properly ventilated areas.
- Keep trash and other objects away from engine.
- Escaping fluids under pressure can penetrate your skin. Use a piece of cardboard or wood, not your hands, to search for leaks.
- Avoid wearing loose clothing without a belt when working around engines.
- Do not oil or grease engine while it is running.
- Use caution in handling fuel. Never refuel a hot or running engine. Do not smoke while filling fuel tank or servicing fuel system.
- Keep your hands, feet, hair and clothing away from power-driven parts.
- Check for any loose electrical connections or faulty wiring.
- Engines should be operated only by knowledgeable, qualified personnel.
- Look completely around engine to make sure that everything is clear before starting.
- Do not operate an engine that isn't in proper working order. If an unsafe operating condition is noted, tag the set and control panel so others will also know about the problem.
- Provide first aid kits.



**CAUTION:** *This symbol is used throughout this book to alert you to possible danger areas. Please take special notice of these sections.*

### **CALIFORNIA Proposition 65 Warning:**

*Diesel engine exhaust and some of its constituents are known to the State of California to cause cancer, birth defects, and other reproductive harm.*

## Industrial Generator Component Locations

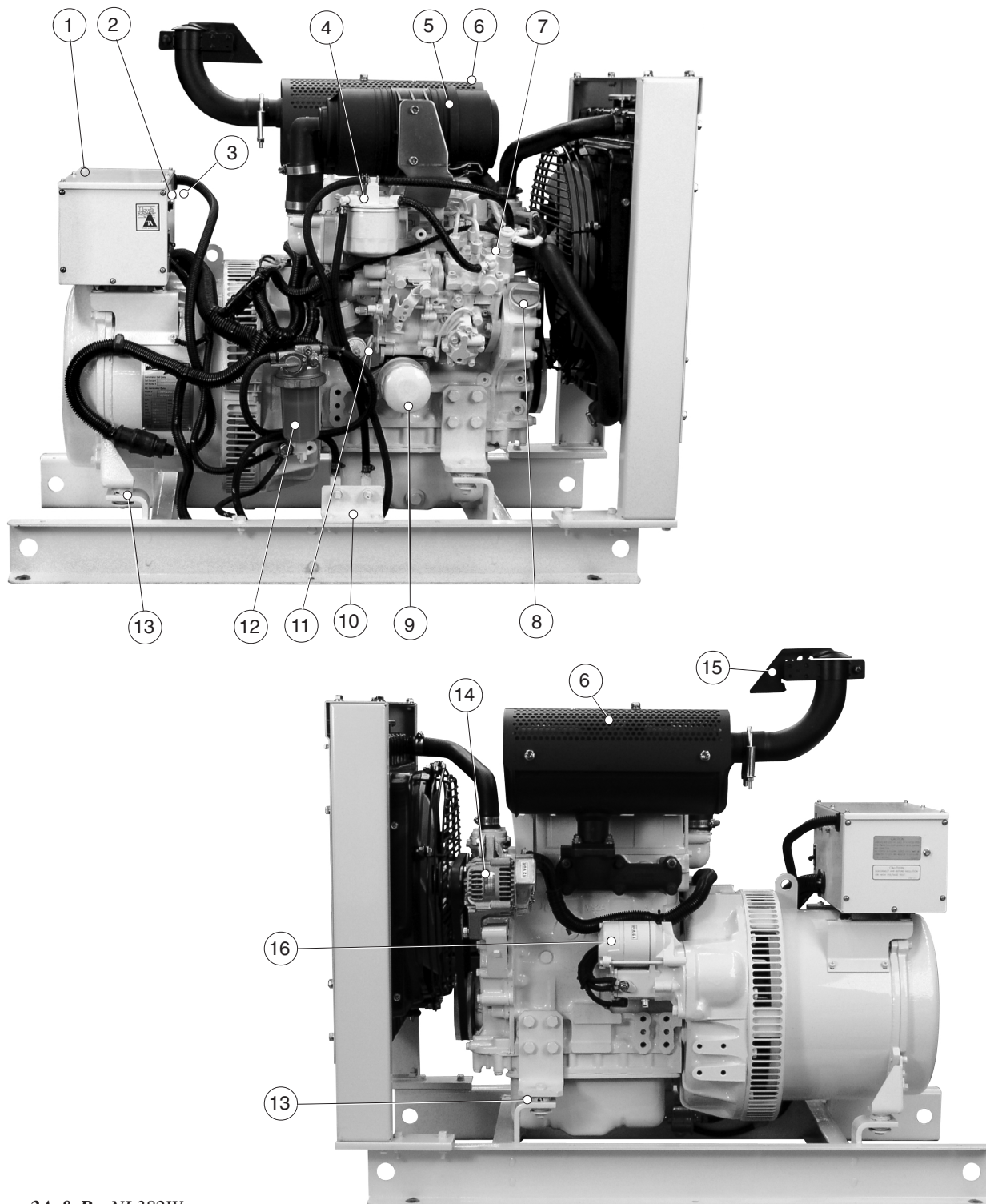

**Figure 2A & B:** NL382W

- |                           |                        |                          |                                  |
|---------------------------|------------------------|--------------------------|----------------------------------|
| 1. Generator Junction Box | 6. Muffler             | 10. Fuel Return Manifold | 14. Alternator                   |
| 2. DC Circuit Breaker     | 7. Fuel Injection Pump | 11. Lube Oil Dipstick    | 15. Muffler Outlet with Rain Cap |
| 3. AVR Fuse               | 8. Lube Oil Fill       | 12. Primary Fuel Filter  | 16. Starter                      |
| 4. Secondary Fuel Filter  | 9. Lube Oil Filter     | 13. Centerbonded Mounts  |                                  |
| 5. Air Cleaner            |                        |                          |                                  |



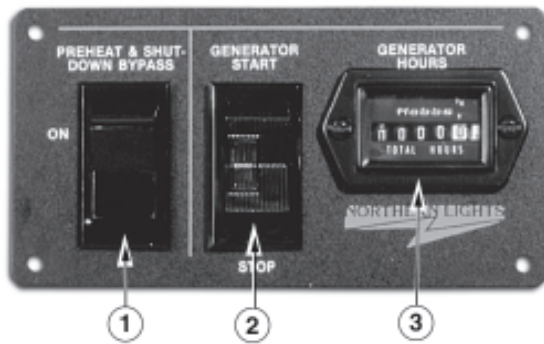

Figure 3-A: Series 1-B Generator Control Panel



Figure 3-B: Series 3 Generator Control Panel

### 1. SHUTDOWN BYPASS-PREHEAT SWITCH

There are two functions built into this switch: preheating the engine and bypassing the engine safety shutdown circuit, enabling a quicker start. Hold the switch in the ON position for approximately 10 to 20 seconds before starting a cold engine. Holding the switch ON for too long can burn out the glow plugs. *NOTE: Three position Engine Control switches must be in the RUN position during preheating. Preheat switch must be held in ON position during starting.*

### 2. ENGINE CONTROL SWITCH

To start the engine, hold this switch in the START position until the engine is running.

After the engine starts, release the switch and it will return to RUN position. To stop the engine, hold the switch in the STOP position.

*NOTE: The rocker switch is used on Series 1 panels only, and has a light that glows when the set is running.*

### 3. HOUR METER

Keeps track of engine running time.

### 4. OIL PRESSURE GAUGE

Shows the oil pressure in the engine lubricating system.

### 5. WATER TEMPERATURE GAUGE

Registers the temperature of the cooling water.

### 6. D.C. VOLTMETER OR AMMETER

When the engine is stopped, the voltmeter indicates the condition of the battery. When the engine is running, the voltmeter indicates the voltage output of the alternator.

## Control Panels

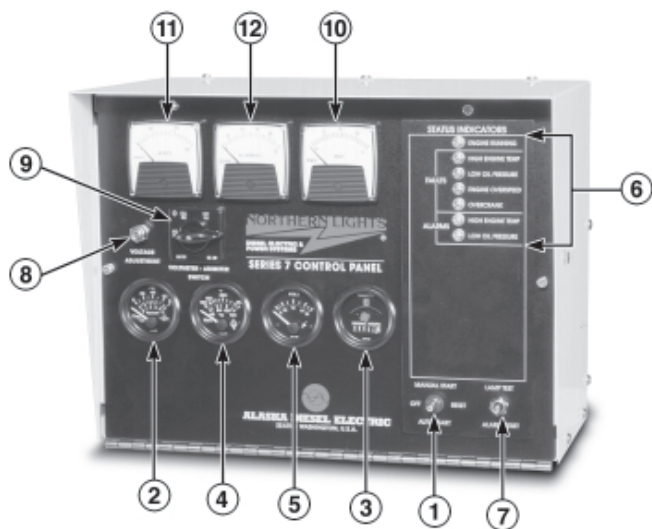

**Figure 4:** Series 7.1 through Series 7.6 Generator Control Panels.

### 1. SHUTDOWN BYPASS SWITCH

Manual Start Panels  
(S-7.1 and S-7.3)

Hold the switch in the START position until the engine is running.

*NOTE: Excessive cranking may cause engine damage.*

After the engine starts, release the switch and it will return to the RUN position. To stop the engine, hold the switch in the STOP position.

Auto Start Panels  
(S-7.2, S-7.4, S-7.5, and S-7.6)

When the switch is placed in the AUTO START position, the unit will automatically start when there is a drop in utility power.

### 2. OIL PRESSURE GAUGE

Shows the oil pressure in the engine lubricating system.

### 3. HOUR METER

Keeps track of engine running time.

### 4. ENGINE TEMPERATURE GAUGE

Registers the temperature of the coolant.

### 5. D.C. VOLTMETER

When the engine is running, the voltmeter indicates the voltage output of the alternator.

### 6. STATUS INDICATOR PANEL

Engine monitoring alarms and lamps for monitoring engine functions.

### 7. ALARM LAMP TEST AND RESET BUTTON

Press UP to test the indicator lights and press DOWN to reset the alarm.

### 8. A.C. VOLTAGE ADJUSTMENT RHEOSTAT

Voltage has been set at the factory and should only be adjusted by factory-trained personnel.

### 9. AMMETER SELECTOR SWITCH

Used to check each phase for load condition.

*NOTE: Always leave this switch in the ON position while the unit is running.*

### 10. FREQUENCY METER (HERTZ)

The frequency meter indicates alternator current frequency: 60 Hz (1200 or 1800 RPM), or 50 Hz (1500 RPM).

### 11. A.C. VOLTMETER

Shows the generator output voltage.

### 12. A.C. AMMETER

Shows the generator load on each phase. The phase is selected with the Ammeter Selector switch (Item 9).



### BREAK-IN PERIOD

1. The first 100 hours on a new or reconditioned engine are critical to its life and performance.
2. Constantly check the engine temperature and oil pressure gauges.
3. Oil consumption is greater during break-in as piston rings take time to seat.
4. Break-In Oil Changes: Change engine oil and filter at 50 hours. Change oil and filter again at 100 hours (consult Lubricants section for oil recommendation), then every 250 hours.
5. Retighten head bolts at 50 hours.

#### Operating Instructions:

Maintain at least a 75% load on your generator set for the first 100 hours. If this is not possible, maintain no less than a 50% load to ensure proper seating of the piston rings. Vary the load to help seat the rings.

### BEFORE STARTING

1. Check the water level by removing the pressure cap from the radiator. In order to give the cooling water an opportunity to expand, the level should be about 1 in. (2.5 cm) below the filler cap sealing surface when the engine is cold.



**CAUTION:** Use protective clothing and open the filler cap carefully when the engine is warm to prevent burns.

2. Check the oil level in the crankcase with the dipstick. The oil level must be between high and low marks on the stick. Never allow the level to go below this area. Always add the same viscosity of oil as is already in the crankcase.
3. Check the fuel tank level and open any fuel valves on the tank and at the secondary fuel filter.
4. Turn on any optional battery switch that may have been installed.

### STARTING

1. Hold the Shutdown Bypass-Preheat switch in the ON position for 10 to 20 seconds before starting a cold engine. Holding the switch too long can burn out the heater elements. This step is not necessary if the engine is already warm.
2. While holding the Shutdown Bypass-Preheat switch in the ON position, push the Engine Control switch to the START position.
3. As soon as the engine starts, release both switches. Do not crank the starter for more than 20 seconds consecutively. If the engine fails to start with the first attempt, be sure that it has stopped completely before re-engaging.

### OPERATING

1. Units with Series 3 and Series 7 Control Panels: check gauges often. Oil pressure must be above 15 PSI. The D.C. voltmeter should read between 11 and 15 volts at 80°F (25°C) ambient temperature. The water temperature gauge must be below 200°F (94°C). Check the A.C. voltage and frequency meters (Series 7 panel). If the gauges deviate from normal levels, shut down the generator set and investigate.
2. Let the unit run unloaded for a three to five minute warm-up period.
3. Add electrical load.

### STOPPING

1. Remove electrical load from the generator set.
2. Run the engine for a three to five minute cool-down period.
3. Move the Engine Control switch to the STOP position until the engine stops completely.
4. Shut off fuel valve at the tank.

## Operating Procedures

### SHUTDOWNS AND ALARMS

1. Your unit is fitted with a system to protect it from high water temperature or low oil pressure.
  - a. Generator sets have shutdown systems to stop the engine. They have no warning horns.
  - b. Other alarms and shutdowns are available as optional equipment.

***NOTE: If your unit is equipped with optional shutdowns and alarms, do not rely on your warning or shutdown system to the exclusion of careful gauge monitoring. Watching your gauges can prevent damage to the unit and dangerous power losses.***

2. Do the following when your warning or shutdown system is activated:

Depress the shutdown bypass switch and check the temperature gauge. If above 230°F (110°C), use the Trouble Shooting Guide on page 19 to isolate the cause of the overheat.



***CAUTION: Do not remove the water fill cap of an overheated engine. Escaping high temperature steam can cause severe burns. Allow the engine to cool and then remove the cap slowly using protective clothing.***

- c. Make repairs and restart after the temperature gauge registers below 210°F (99°C).
  - d. Watch the temperature gauge regularly and turn off the unit if the temperature rises above 220°F (105°C). Repeat troubleshooting.
3. If shutdown is activated and the temperature gauge shows temperature within normal temperature range:
  - a. Check the engine crankcase oil level.
  - b. If the oil level is low, fill with recommended lubricating oil and restart. Watch the oil pressure gauge carefully and shut off the engine if it does not show a normal reading (20-60 PSI) after a few seconds of operation.
  - c. If the oil level is normal, DO NOT restart the engine. Call your dealer for assistance.

### SPARE PARTS

1. ADE recommends that you keep the following spare parts on hand for field service. The parts are available from your local Northern Lights dealer.
  - a. Primary and secondary fuel filter elements
  - b. Oil filters
  - c. Air filter elements
  - d. Alternator belt
  - e. Thermostat and gaskets
  - f. Heater element
  - g. Injector and washer
2. If your set is operating a long distance from a servicing dealer, add the following:
  - a. Complete set of injectors
  - b. Fuel lift pump

## Servicing Schedule Chart

The Servicing Schedule Chart below shows the service schedule required for proper maintenance of your generator set. More detailed coverage of each Service Point (SP) is listed on the page noted in the 'page' column.

**DAILY:**

- SP1 Check oil level in engine
- SP4 Check air cleaner dust trap, replace element @250 hrs. or when needed
- SP8 Check primary fuel filter
- SP14 Check cooling water level

**AFTER FIRST 50 HOURS:**

- SP2/3 Change engine oil and filter
- SP5 Check V-belt tension
- SP6 Re-tighten cylinder head bolts

**EVERY 50 HOURS:**

- SP5 Check V-belt tension
- SP11 Bleed the fuel system
- SP17 Check electrolyte in batteries

**EVERY 250 HOURS:**

- SP2/3 Change engine oil and filter
- SP5 Check V-belt tension
- SP9 Change primary fuel filter element
- SP10 Change secondary fuel filter
- SP11 Bleed the fuel system
- SP16 Check and clean radiator

**EVERY 500 HOURS:**

- SP12 Check injectors
- SP18 Check state of charge of batteries

**EVERY 1000 HOURS:**

- SP7 Check valve clearances
- SP20 Check fuel injection nozzle pressure

**EVERY 2000 HOURS:**

- SP13 Check fuel injection pump
- SP15 Check and flush cooling system

SERVICE POINT	PAGE	OPERATION	DAILY	50 Hours	250 Hours	500 Hours	1000 Hours	2000 Hours
<b>ENGINE:</b>								
SP1	11	Check oil level	●					
SP2	11	Change engine oil 1)		5)	●			
SP3	11	Change lube oil filters 1)		5)	●			
SP4	11	Check air cleaner, replace element 1) 4)	●		●			
SP5	12	Check V-belt tension 1)		●	●			
SP6 & 7	12	Re-tighten cyl. head bolts, Check valve clearances 4)		5)			●	
<b>FUEL SYSTEM:</b>								
SP8	13	Check primary filter 2)	●					
SP9	13	Change primary filter element 2) 3)			●			
SP10	13	Change secondary fuel filter 1) 3)			●			
SP11	14	Bleed the fuel system 3)		●				
SP12	14 - 15	Check injectors 1) 7)				●		
SP20		Check fuel injection nozzle pressure 7)					●	
SP13	15	Check fuel injection pump 7)						●
<b>COOLING SYSTEM:</b>								
SP14	15	Check cooling water level	●					
SP15	15	Check and flush cooling system						●
SP16	15	Check and clean radiator fins			●			
<b>ELECTRICAL SYSTEM:</b>								
SP17	16	Check electrolyte level in batteries 1) 4)		●				
SP18	16	Check condition of batteries with hydrometer 1)				●		
<b>OUT OF SERVICE:</b>								
SP19	16	Winterizing or out-of-service 3)						

- 1) Perform all maintenance once a year even if hour level has not been reached.
- 2) Consult manufacturer's maintenance schedule, note on chart.
- 3) Whenever necessary.
- 4) More often if necessary.
- 5) After first 50 hours.

- 6) Adjust at first 100 hours.
- 7) For EPA emission standards fuel nozzle needs to be cleaned every 1500 hours, the fuel nozzle and fuel pump need to be cleaned, adjusted, or repaired every 3000 hours, and the quality guarantee for these parts is 3000 hours or 5 years.

## Service Record

Service Point	OPERATION	HOURS/DATE									
<b>50 HOURS</b>											
SP5	Check V-belt tension										
SP17	Check electrolyte in batteries										

<b>250 HOURS</b>											
SP2	Change engine oil										
SP3	Change lubricating oil filters										
SP4	Check air cleaner										
SP9	Change primary filter element										
SP10	Change secondary fuel filter										
SP16	Check and clean radiator										

<b>500 HOURS</b>											
SP12	Check injectors										
SP18	Check condition of batteries with hydrometer										

<b>1000 HOURS</b>											
SP6	Re-tighten head bolts (after first 50 hrs.)										
SP7	Check valve clearances										
SP20	Check fuel injection nozzle pressure										

<b>2000 HOURS</b>											
SP13	Check fuel injection pump										
SP15	Check and flush cooling system										

**Service Notes:**

**LUBRICATION - GENERAL**

1. Use only clean, high quality lubricants stored in clean containers in a protected area.
2. These lubricants are acceptable:
  - a. API Service CC/CD/CE single viscosity oils.
  - b. API Service CC/CD/SF multi-viscosity oils.
3. Use the proper weight oil for your average operation temperature.

Air Temperature	Single Viscosity	Multi-Viscosity
Above 32°F (0°C)	SAE 30W	SAE 15-40W
-10 to 32°F (-23 to 0°C)	SAE 10W	SAE 10-30W
Below -10°F (-23°C)	SAE 5W	SAE 5-20W

*Figure 5: Lube Oils*

4. Some increase in oil consumption may be expected when SAE 5W and SAE 5-20W oils are used. Check oil level frequently.
5. Never put additives or flushing oil in crankcase.

**SP1. CHECKING OIL LEVEL**

1. Check the oil level in the crankcase with the dipstick daily. The oil level must be between the high and low marks on the stick. Fill with the recommended oil, and fill only to the high mark on the dipstick. Follow the lubrication recommendations above.

**SP2. OIL CHANGES**

1. The set is delivered with special break-in oil. Change the engine oil and oil filter after 50 hours of operation. Use Service CC 30 weight oil during the first 100 hours.
2. Change the oil and filter again at 100 hours using the oil recommended in the above diagram. After this, change oil and filter every 250 hours.
3. During intermittent cold weather operation, change oil every 100 hours or six weeks, whichever comes first.

4. Change oil at any seasonal change in temperature when a new viscosity of oil is required.
5. Change oil when engine is warm but not hot.
6. Dispose of waste oil in an approved manner.
7. Never use a flushing oil.
8. Loosen plug in oil pan and drain oil into basin.
9. Refill engine with recommended oil.
10. Engine capacity with new oil filter is:

382 – 5.81 quarts (5.5 liters)

**SP3. CHANGING LUBE OIL FILTER**

1. Change the lube oil filter every 250 hours.
2. Use a filter wrench to remove old filter. Dispose of filter in approved manner.
3. Make sure the gasket from the old filter is removed and discarded. Clean mount face.
4. Spread a thin film of engine oil on the rubber gasket on the new filter and screw it on nipple until gasket meets the sealing surface.
5. Using hands only – no wrench – tighten filter one-half turn farther. Overtightening can do damage to filter housing.
6. Fill engine with recommended oil. Start engine and check for leakage. Stop engine, wait 3 minutes, and check oil level. Add additional oil if necessary.
7. Oil filter part number is: #24-07301.

**SP4. AIR CLEANER**

1. Check dust trap on bottom of air cleaner daily. Squeezing the lips of the rubber cap allows dirt to fall out.
2. Visually inspect air cleaner every 250 hours. In dusty conditions, check more often.
3. An element cannot be cleaned. Replace dirty elements when necessary. Part numbers are:

NL382W – #24-27302

**NOTE:** *Make absolutely sure no impurities enter the engine while changing the element, and do not run the engine with the air cleaner removed.*

# Servicing

## SP5. V-BELTS

1. Check the tension and wear on the V-belt after every 50 hours.
2. Use your thumb to press on the belt at the midpoint between the crankshaft and alternator pulleys. The tension is correct if the belt can be depressed about 10-14 mm at point A, 7-10 mm at point B, and 9 to 13 mm at point C for a belt used on a running engine for more than 5 minutes (Fig. 6).

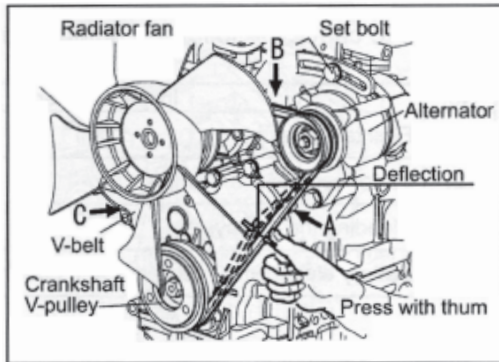

Figure 6: Alternator Drive Belt (V-belt) Adjustment

3. To adjust the belt tension, loosen bolt in the tensioning arm and move the alternator to tighten the belt. If the belt has to be replaced, adjust it and then run the engine for 5 minutes and re-adjust if needed.

## SP6. RETIGHTENING CYLINDER HEAD BOLTS

1. Retighten the head bolts after the first 50 hours.
2. Tighten bolts when the engine is cold.
3. Loosen the nuts and remove rocker arm cover.
4. Tighten head bolts with a torque wrench in the order shown in figure 7. Tighten bolts evenly in 2 or 3 passes, ending at the specified torque in final pass.
5. Replace rocker arm cover.

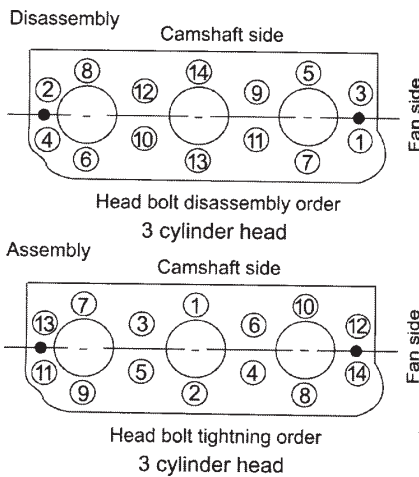

Figure 7: 3  
Cylinder Head  
Torque Sequence

Tightening Torque specifications:

First Step: 30.0 to 34.0 N•m (3.1 to 3.5 kgf•m)

Second Step: 61.7 to 65.7 N•m (6.3 to 6.7 kgf•m)

## SP7. VALVE CLEARANCES

1. Readjust valve clearance after first 50 hours of operation. Adjust valves every 1000 hours thereafter.
2. Valve adjustments should be done after the cylinder head bolts have been re-tightened. Engine should be cold and NOT running.
3. Remove the rocker arm cover.
4. Watch the valves while turning the engine over by hand. Turn until the inlet valve starts to open and the exhaust valve starts to close (the valves are rocking). Then turn the crankshaft one more full turn and adjust the clearance on both valves for this cylinder.
5. To adjust, insert a thickness gauge in between the rocker arm and valve cap. Then loosen the lock nut and adjust the clearance between the rocker arm and valve cap of both the intake and exhaust valves with the adjustment screw (Figures 8 and 9). Clearance on intake and exhaust valves should be 0.006 - .01 in. (0.15 - 0.25 mm).

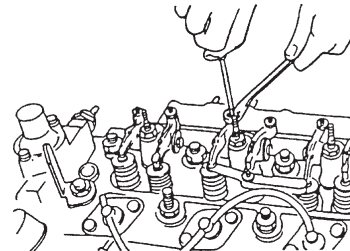

Figure 8: Valve Adjustment

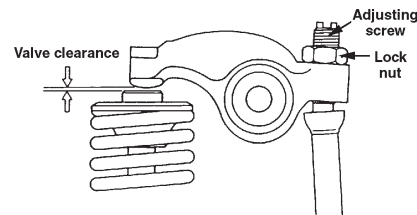

Figure 9: Valve Clearance

6. Turn the crankshaft 240° and adjust the No. 3 cylinder, then the No. 2.
7. Replace the rocker arm cover.



**FUELS - GENERAL**

1. Use only clean, high quality fuels of the following specifications, as defined by ASTM designation D975 for diesel fuels:
  - a. Use grade no. 2 diesel at ambient temperatures above freezing 32°F (0°C).
  - b. Use grade no. 1 at ambient temperatures below freezing and for all temperatures at an altitude of above 5,500 ft. (1500 meters).
  - c. International fuel specifications:  
 ISO-8217-DMA  
 BS 2869 Part 1 Class A1  
 BS 2869 Part 2 Class A2
2. Use fuel having less than 1% sulphur (preferably less than 0.5%).
3. The cetane number should be a minimum of 45.
4. DO NOT use these unsuitable grades of fuel:
  - a. Domestic heating oils, all types.
  - b. Class B engine.
  - c. Class D domestic fuels.
  - d. Class E, F, G or H industrial or marine fuels.
  - e. ASTM-D975-60T No. 4-D and higher number fuels.
5. Storing fuel:
  - a. Keep dirt, scale, water, and other foreign matter out of fuel.
  - b. Avoid storing fuel for long periods of time.
  - c. Fill the fuel tank at the end of each day's operation. This will reduce condensation.

2. Change secondary fuel filter every 250 hours.  
 NOTE: The fuel filter on the engine is considered the "secondary fuel filter". The engine will be fitted with an element or cannister type secondary fuel filter.

- a. Element:
 

Turn off the fuel valve. Remove the bowl retaining ring by hand. Dispose of fuel and contaminants from bowl and wipe clean. Put in new element. Fill bowl with fuel and replace by tightening retaining ring. Open fuel valve.
- b. Spin-on type filter:
 

Turn off the fuel valve. Remove the spin-on filter by turning it counterclockwise with a filter wrench. Fill the new cartridge with fuel and install it after applying engine oil to gasket surface. Screw on until the gasket surface comes into contact with the sealing surface of the filter base. Then, follow instructions on filter regarding additional tightening. Do not overtighten. Open fuel valve.
- c. Fuel filter part numbers are:
 

Model	Part Number	
NL382W	#24-57304	Final Fuel Filter
	#119802-55710	Primary Fuel Filter

**SP8-10. FUEL FILTERS**

1. Your generator set should have a primary fuel filter installed. We recommend the Northern Lights brand of fuel filter-water separators.
  - a. Check the primary fuel filter daily as recommended by the filter manufacturer. Empty the collection bowl as necessary.
  - b. Change the element as often as necessary or every 250 hours.
  - c. If the bowl fills with water, change the primary and secondary element immediately.

## SP11. BLEEDING THE FUEL SYSTEM

**CAUTION:** Escaping diesel fuel under pressure can penetrate skin causing serious personal injury. Before disconnecting lines be sure to relieve all pressure. Before applying pressure, be sure all connections are tight and lines, pipes and hoses aren't damaged. Fuel escaping from a very small hole can be almost invisible. Use a piece of cardboard or wood, rather than hands, to search for suspected leaks. If injured by escaping fuel, see a doctor at once. Serious infection or reaction can develop if proper medical treatment isn't administered immediately.

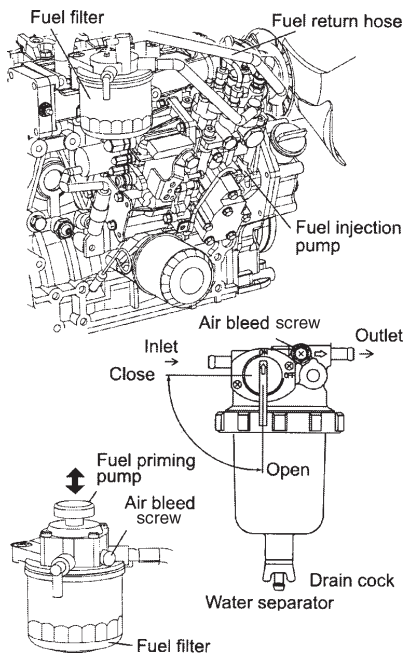

Figure 10: Bleeding Fuel System

1. The fuel system is self-bleeding. However, any system may need manual bleeding when:
  - a. A new fuel filter is installed;
  - b. The engine has run out of fuel;
  - c. The fuel lines, injection pump or any other fuel system component has been removed and installed.
2. Loosen bleed screw on top of the fuel filter (Figure 10). Pump hand primer on fuel lift pump until pure fuel (no bubbles) escapes from bleed screw. Tighten bleed screw.
3. Loosen bleed screw on the injection pump. Pump hand primer until pure fuel (no bubbles) escapes. Tighten bleed screw.

4. If the engine does not start after this bleeding process, loosen a fuel line at the injector while cranking the engine with the starter motor until pure fuel escapes. Then tighten the connection. Do each line **one-at-a-time**.
5. After the engine has started, use a piece of cardboard to look for fuel leaks.

## SP12. INJECTOR SERVICE

1. Injectors should be checked every 500 hours. Check should be made by a Northern Lights dealer or local injection repair station.

**CAUTION:** Escaping diesel fuel under pressure can have sufficient force to penetrate the skin causing serious personal injury. If injured by escaping fuel, see a doctor at once.

2. Injector removal:
  - a. Clean loose dirt from around the injectors and the fuel lines.
  - b. Relieve high pressure in the fuel lines by loosening the delivery line flare nuts at each injector.
  - c. Remove delivery lines by disconnecting from injectors and injection pump.  
Remove all lines as an assembly; do not remove the spacers. Cover the ends of the lines, the injector inlets and injection pump outlets to keep dirt out.  
**NOTE:** On some models it is necessary to remove the air filter housing to access the fuel injection lines.
  - d. Remove the return line retaining clamps and remove the return lines.
  - e. Remove the nuts on each side of the injector body. Remove the hold-down bracket with a 6 mm wrench or socket. Pull the injector body from the hole.  
**NOTE:** Do not use pry bars to remove injectors from cylinder head.
  - f. After removing the injectors, discard the sleeves from the injector hole in the head. Cover holes to prevent dirt and debris from entering the cylinders.  
**IMPORTANT:** Make sure you pull the sleeve out of the injector hole, as it may not come out with the injector.

3. Injector repair and cleaning
  - a. Take injectors to your Northern Lights dealer or local injection repair station for testing and service.
4. Injector installation:
  - a. Place new sleeve in injector hole. Slide injector into hole or on the injector. replace hold-down bracket and nuts. Tighten nuts evenly to 18 - 20 ft-lbs. (2.5 - 2.9 kgf-m).
  - b. Install fuel lines.
  - c. Install return lines and clamps.
  - d. Install delivery lines. Leave loose at injectors for bleeding.
  - e. Pump hand lever on fuel pump to fill lines. Tighten lines at injectors. Start engine and check for leaks using a piece of paper or cardboard.  
**DO NOT use hand to check for leaks.**

### SP13. INJECTION PUMP

1. Since operating conditions may vary considerably, it is difficult to give a definite interval for checking the injection pump. But as a rule, pump settings, maximum speed, idle speed and exhaust smoke should be checked after every 2000 hours of operation. Service of the fuel injection pump should only be done if checks indicate pump malfunction.
2. Black smoke can be an indication of pump malfunction. Before servicing the pump, check other possible causes:
  - a. Check cleanliness of air filter.
  - b. Check valve clearances.
  - c. Clean and check injectors.
3. Any repair which involves disassembly of the injection pump must be carried out by specially trained mechanics with the proper tools and test equipment.

**NOTE:** *All warranties on the engine become null and void if the injection pump seals are broken by unauthorized persons.*

### COOLING SYSTEM - GENERAL



**CAUTION:** *The cooling water in the engine reaches extremely high temperatures. You must use extreme caution when working on hot engines to avoid burns. Allow the engine to cool before working on the cooling system. Open the filler cap carefully, using protective clothing when the engine is warm.*

### SP14. CHECK THE COOLANT LEVEL

1. Check the coolant level each day before starting the engine.
  - a. Check the water level by removing the pressure cap from the radiator. In order to give the cooling water an opportunity to expand, the level should be about 1 in. (2.5 cm) below the filler cap sealing surface when the engine is cold.
  - b. The pressure valve in the filler cap releases when the pressure is approximately 12 PSI (0.9 kgm/cm<sup>2</sup>). Use a cap pressure tester to check cap if you suspect it is faulty.

### SP15. COOLING SYSTEM FLUSHING

1. Flush the cooling system every 2000 hours or every 12 months, whichever comes first.
2. Remove radiator cap and open drains on radiator and engine block. The radiator drain is a rubber cap on the bottom of the radiator. Loosen the hose clamp and remove the clamp and cap. The hex-headed engine block drain is on the service side of the engine below the intake manifold, next to the flywheel housing.
3. Pour clean water into radiator until water coming from radiator is clear of discoloration. Close the radiator drain and continue flushing until water from engine drain is clear. Open all drains and drain the engine and radiator completely. Close drains and refill the radiator with recommended coolant mixture.
4. Use 50% water / 50% ethylene glycol antifreeze mix. Antifreeze mixture is recommended as a good year-round coolant.
5. Check hoses and connections and repair any leakage.
6. Start the engine and check for leaks. Run the engine for five minutes, then shut it down. Let engine cool, and then check the coolant level in the radiator. Add coolant as needed.

### SP16. CLEAN RADIATOR

1. Remove debris from radiator fins daily.
2. In very dusty applications, clean the radiator with compressed air or steam cleaner every 100 hours. Clean in the reverse direction of the airflow.

## Servicing

### GENERATOR ENDS

The maintenance and operation recommendations for the generator end are in a separate Owner's Manual. If you do not have one of these manuals, contact your local Northern Lights dealer.

### ELECTRICAL SYSTEM - GENERAL

1. Never turn an optional battery switch off or break the circuit between the alternator and batteries while the engine is running. Regulator damage can result.
2. Do NOT reverse the polarity of battery cables when installing the battery.
3. When welding on the unit, disconnect the regulator and battery. Isolate the leads.
4. Disconnect the battery cables when servicing the D.C. alternator.
5. Never test with a screwdriver, etc., against any terminal to see if it emits sparks.
6. Do not polarize the alternator or regulator.
7. A D.C. circuit breaker protects your control panel and wiring harness. It is located in the side of the generator junction box.

### INTAKE HEATER

Model NL488 has a heater element in the end of the intake manifold. To test the heater element, remove the power wire from the terminal. Connect D.C. test bulb between the positive (+) pole of the battery and the terminal of the heater. If the bulb lights up, the heater is functioning properly. If not, the heater isn't functioning, and the heater elements need replacing.

### BOOSTER BATTERIES



**CAUTION: Battery gas can explode.**  
**Keep all flames and sparks away from batteries.**

1. Before changing or using booster batteries, check battery electrolyte level. Add distilled water if necessary.
2. Booster and main batteries must have the same voltage rating.
3. First, connect positive (+) terminal of booster battery to positive (+) terminal of main battery. Then, connect negative (-) terminal of booster battery to ground on the engine block (see Figure 11).

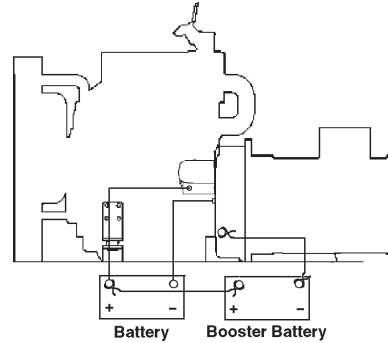

**Figure 11: Battery Connections**

4. Remove booster battery after starting engine.
5. Sealed batteries: See manufacturer charging and booster instructions.

### SP 17-18. BATTERY CARE

1. Check electrolyte level every 50 hours or once per month. Add distilled water to manufacturer's recommended level.
2. Batteries, cables and cable terminals should be checked and cleaned every 100 hours. Clean corrosion with a water and baking soda solution. Flush with clean water. Tighten terminals and grease them to inhibit corrosion.
3. Check the battery condition with a hydrometer every 500 hours.

### SP19. WINTERIZING / OUT-OF-SERVICE

1. Drain and flush the radiator and cooling system. Leave dry or refill with antifreeze-water mixture. If refilling, start the engine and run to circulate the antifreeze.
2. Fill the fuel tank or add biocide as per manufacturer's instructions.
3. Seal the air cleaner inlet, exhaust opening, crankcase breather pipe, and fuel tank vent with plastic bags and tape.
4. Change the crankcase oil and filter.
5. Loosen the alternator belt.
6. Disconnect and clean battery. Remove to warm storage place if possible.
7. Clean outside of unit. Paint any scratched or chipped surfaces. Put corrosion preventative on all exposed metal surfaces.
8. Store the set in a dry, protected place. If unit must be stored outside, be sure it is well protected with a cover.

### DC ELECTRICAL SYSTEM

PROBLEM	POSSIBLE CAUSE	RECOMMENDATION(S)
<b>Battery Will Not Charge</b>	Loose or corroded connections	<ul style="list-style-type: none"> <li>• Clean and tighten battery connections.</li> </ul>
	Sulfated or worn out batteries	<ul style="list-style-type: none"> <li>• Check specific gravity of each battery.</li> <li>• Check electrolyte level of each battery.</li> </ul>
	Loose or defective alternator belt	<ul style="list-style-type: none"> <li>• Adjust belt tension.</li> <li>• Replace belt.</li> </ul>
<b>Starter Inoperative</b>	Check DC circuit breaker	<ul style="list-style-type: none"> <li>• If the breaker is tripped, reset it.</li> </ul>
	Loose or corroded connections	<ul style="list-style-type: none"> <li>• Clean and tighten loose battery and harness plug connection.</li> </ul>
	Low battery output	<ul style="list-style-type: none"> <li>• Check specific gravity of each battery.</li> <li>• Check electrolyte level of each battery.</li> </ul>
	Defective electrical system ground wire:	<ul style="list-style-type: none"> <li>• Repair or replace.</li> </ul>
<b>Starter Cranks Slowly</b>	Low battery output	<ul style="list-style-type: none"> <li>• Battery is too small.</li> <li>• Battery cables are too small.</li> </ul>
	Check specific gravity of each battery	<ul style="list-style-type: none"> <li>• Replace battery if necessary.</li> </ul>
	Check electrolyte level of each battery	<ul style="list-style-type: none"> <li>• If low, fill cells with distilled water.</li> </ul>
	Crankcase oil too heavy	<ul style="list-style-type: none"> <li>• Fill with oil of appropriate viscosity.</li> </ul>
	Loose or corroded connections	<ul style="list-style-type: none"> <li>• Clean and tighten loose connections.</li> </ul>
<b>Entire Electrical System Does Not Function</b>	Check DC circuit breaker	<ul style="list-style-type: none"> <li>• If breaker is tripped, reset it.</li> </ul>
	Faulty connection	<ul style="list-style-type: none"> <li>• Clean and tighten battery and harness plug connections.</li> </ul>
	Sulfated or worn out batteries	<ul style="list-style-type: none"> <li>• Check specific gravity and electrolyte level of each battery.</li> </ul>

If you cannot correct problems with these procedures, see your **Northern Lights** dealer.

## Troubleshooting

### ENGINE

PROBLEM	POSSIBLE CAUSE	RECOMMENDATION(S)
<b>Engine Hard to Start or Will Not Start</b>	Improper starting procedure	• See starting section of this manual. Take special note of Bypass Switch operation.
	No fuel	• Check level of fuel in fuel tank.
	Low battery output	• Check electrolyte level and condition.
	Excessive resistance in starting circuit	• Clean and tighten all battery connections.
	Crankcase oil too heavy	• Use oil of proper viscosity.
	Improper type of fuel	• Consult fuel supplier and use proper type of fuel for operating condition.
	Water, dirt or air in fuel system	• Drain, flush, fill and bleed system.
	Clogged primary fuel filter element	• Clean or replace filter element.
	Clogged secondary fuel filter element	• Replace filter element.
	Dirty or faulty injection nozzles	• Have your dealer check injection nozzles.
<b>Engine Runs Irregularly or Stalls Frequently</b>	Below normal engine temperature	• Remove and check thermostat.
	Clogged primary fuel filter element	• Clean or replace filter element.
	Clogged secondary fuel filter element	• Replace secondary filter element.
	Water or dirt in the fuel system	• Drain, flush, fill and bleed system.
	Dirty or faulty injection nozzles	• Have your dealer check injection nozzles.
	Air in fuel system	• Inspect clamps and hoses on suction side of fuel pump for air leak.
	Improper type of fuel	• Consult fuel supplier and use proper type of fuel for operating condition.
<b>Lack of Engine Power</b>	Intake air restriction	• Service air cleaner.
	Clogged primary fuel filter element	• Clean or replace filter element.
	Clogged secondary fuel filter element	• Replace filter element.
	Improper type of fuel	• Consult fuel supplier and use proper type of fuel for operating conditions.
	Overheated engine	• See "Engine Overheats" in next category.
	Below normal engine temperature	• Remove and check thermostat.
	Improper valve clearance	• Reset valves. Best done by dealer.
	Dirty or faulty injection nozzles	• Replace injectors. Best done by dealer. • See your local dealer.



### ENGINE

PROBLEM	POSSIBLE CAUSE	RECOMMENDATION(S)
<b>Engine Overheats</b>	Low coolant level	<ul style="list-style-type: none"> <li>• Fill tank or radiator to proper level.</li> <li>• Check hoses for loose connections and leaks.</li> </ul>
	Cooling system needs flushing	<ul style="list-style-type: none"> <li>• Flush cooling system.</li> </ul>
	Defective thermostat	<ul style="list-style-type: none"> <li>• Remove and check thermostat.</li> </ul>
	Defective temperature gauge	<ul style="list-style-type: none"> <li>• Check water temperature with thermometer and replace gauge if necessary.</li> </ul>
	Fan belt loose	<ul style="list-style-type: none"> <li>• Adjust belt tension (see page 12).</li> </ul>
<b>Engine Knocks</b>	Insufficient oil	<ul style="list-style-type: none"> <li>• Call your dealer.</li> </ul>
	Injection pump out of time	<ul style="list-style-type: none"> <li>• Call your dealer.</li> </ul>
	Below normal engine temperature	<ul style="list-style-type: none"> <li>• Check your thermostats.</li> <li>• Check water temperature to see if temperature gauge is working properly.</li> </ul>
	Engine overheating	<ul style="list-style-type: none"> <li>• See “Engine Overheating” section.</li> </ul>
	Connecting rod bolt loose	<ul style="list-style-type: none"> <li>• Tighten to torque 44.1 to 49.0 N•m (4.5 kgf-m to 5.0 kgf-m).</li> </ul>
<b>High Fuel Consumption</b>	Improper type of fuel	<ul style="list-style-type: none"> <li>• Use correct fuel for temperature.</li> </ul>
	Clogged or dirty air cleaner	<ul style="list-style-type: none"> <li>• Service air cleaner.</li> </ul>
	Improper valve clearance	<ul style="list-style-type: none"> <li>• See your dealer.</li> </ul>
	Injection nozzles dirty	<ul style="list-style-type: none"> <li>• See your dealer.</li> </ul>
	Injection pump out of time	<ul style="list-style-type: none"> <li>• See your dealer.</li> </ul>
	Engine not at proper temperature	<ul style="list-style-type: none"> <li>• Check your thermostats.</li> <li>• Check water temperature with thermometer and replace gauge if necessary.</li> </ul>
<b>Below Normal Engine Temperature</b>	Thermostats not working properly	<ul style="list-style-type: none"> <li>• Check thermostats.</li> </ul>
	Temperature gauge not working properly	<ul style="list-style-type: none"> <li>• Check water temperature with thermometer.</li> </ul>
<b>Low Oil Pressure</b>	Low oil level	<ul style="list-style-type: none"> <li>• Fill crankcase to proper level.</li> </ul>
	Improper type of oil	<ul style="list-style-type: none"> <li>• Drain and fill crankcase with correct oil.</li> </ul>
	Partially plugged oil filter	<ul style="list-style-type: none"> <li>• Replace filter.</li> </ul>
<b>High Oil Consumption</b>	Break-in period	<ul style="list-style-type: none"> <li>• Oil consumption decreases after break in.</li> </ul>
	Crankcase oil too light	<ul style="list-style-type: none"> <li>• Use proper viscosity oil.</li> </ul>
	Oil leaks	<ul style="list-style-type: none"> <li>• Check for leaks in lines around gaskets and drain plug.</li> </ul>

If you cannot correct problems with these procedures, see your **Northern Lights** dealer.

## Troubleshooting

### ENGINE

PROBLEM	POSSIBLE CAUSE	RECOMMENDATION(S)
<b>Engine Emits Black or Gray Exhaust Smoke</b>	Clogged or dirty air cleaner	• Service air cleaner.
	Defective muffler (back pressure too high)	• Have dealer check back pressure.
	V belt loose	• Adjust the belt (see page 12).
	Improper fuel	• Use correct fuel for temperature.
	Injection nozzles dirty	• See your dealer.
	Engine out of time	• See your dealer.
<b>Engine Emits White Smoke</b>	Intake and exhaust valve timing not set properly	• Adjust valve clearance (see page 12).
	Improper fuel	• Use correct fuel for temperature.
	Cold engine	• Warm up engine to normal operating temperature.
	Defective thermostat	• Remove and check thermostat.
	Engine out of time	• See your dealer.
Intake and exhaust valve timing not set properly	• Adjust valve clearance (see page 12).	

If you cannot correct problems with these procedures, see your **Northern Lights** dealer.

# AC Wiring Diagram

NL382W AC Wiring Diagram  
 PX-310K2 12 & 4 Lead Generators  
 DST-100-2FAK AVR  
 B-8280A

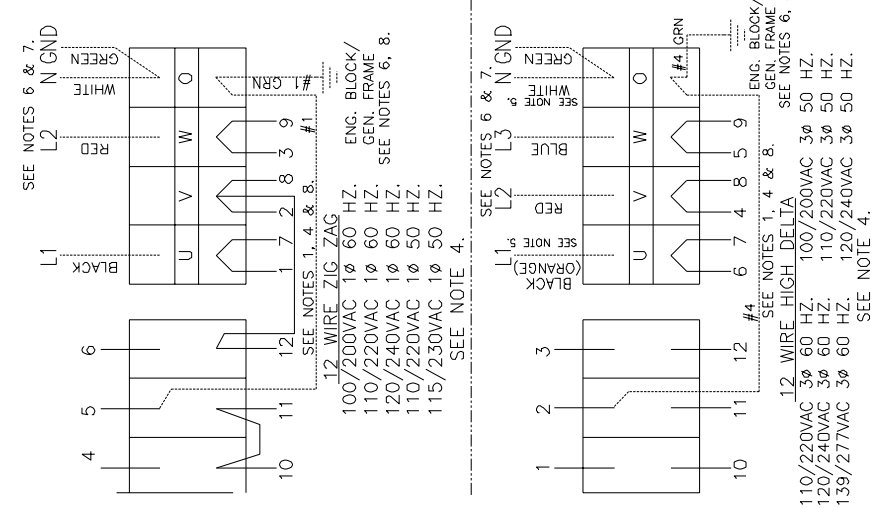
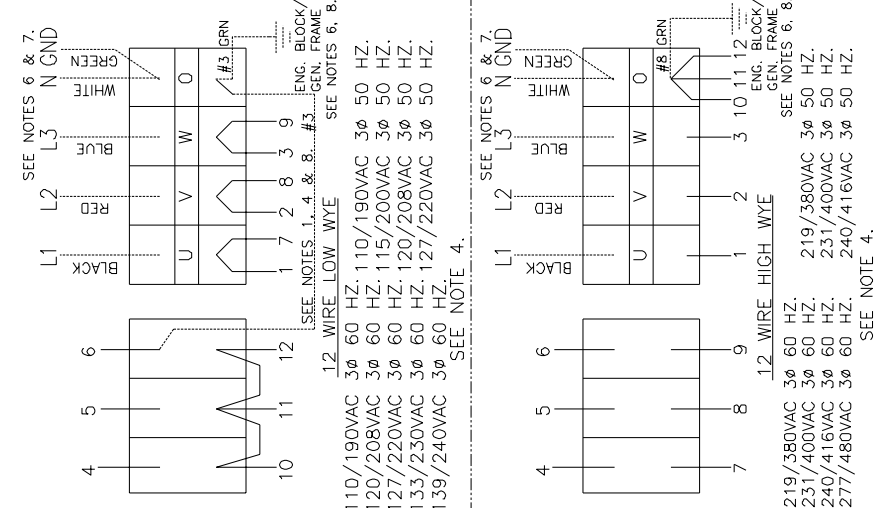
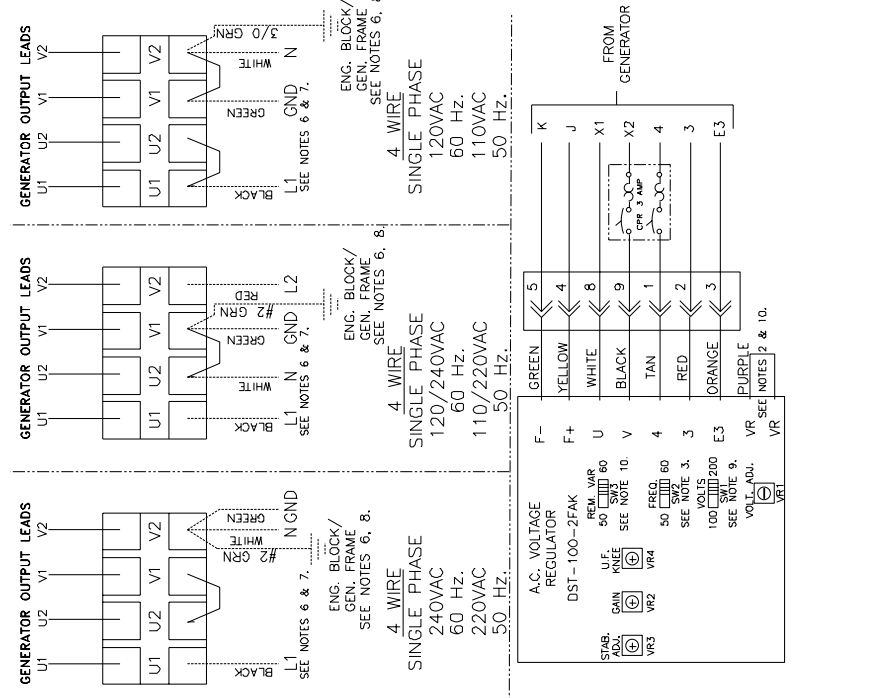

- NOTES: 1. ALL A.D.E. INSTALLED CONDUCTORS ARE TO BE TYPE MTW, 105°C, MULTISTRAND, 600VAC.  
 2. FOR REMOTE VOLTAGE ADJUST RHEOSTAT CUT JUMPER AND SPLICE INTO PURPLE LEADS.  
 3. SET SW2 FOR CURRENT APPLICATION, (50 OR 60 HZ.)  
 4. DELETE NEUTRAL CONDUCTOR (AND JUMPER IF PRESENT), IF LOWER VOLTAGE IS NOT REQUIRED.  
 5. LINE ONE (HIGH LEG) TO BE MARKED ORANGE WHEN NEUTRAL IS PRESENT, IN ACCORDANCE WITH ARTICLE 215-8 OF THE NATIONAL ELECTRIC CODE.  
 6. MARINE GENSETS ARE GROUNDED BY CUSTOMER, AT CUSTOMER'S DISCRETION. INDUSTRIAL GENSETS ARE TO BE GROUNDED IN ACCORDANCE WITH THE NATIONAL ELECTRICAL CODE AND ANY APPLICABLE LOCAL CODES.  
 7. THICK HIDDEN (DASHED) LINES INDICATE CUSTOMER SUPPLIED AND CONNECTED MAIN OUTPUT CONDUCTORS. SIZING TO BE DETERMINED PER INSTALLATION.  
 8. NEUTRAL AND GROUND CONDUCTORS SIZED FOR 33kW UNITS @ LOWEST LISTED VOLTAGE. CONSULT A.D.E. ENGINEERING FOR CONDUCTOR SIZING @ OTHER GENSET VOLTAGE/KW RATINGS.  
 9. INPUT SENSING SWITCH SW1 IS TO BE SET TO THE 200V POSITION FOR ALL VOLTAGES EXCEPT STRAIGHT 120V APPLICATIONS.  
 10. SET SW3 PER APPLICATION IF REMOTE VOLTAGE ADJUST RHEOSTAT IS USED.

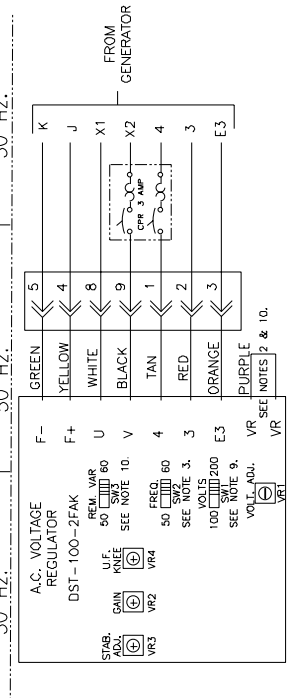

# DC Wiring Diagram

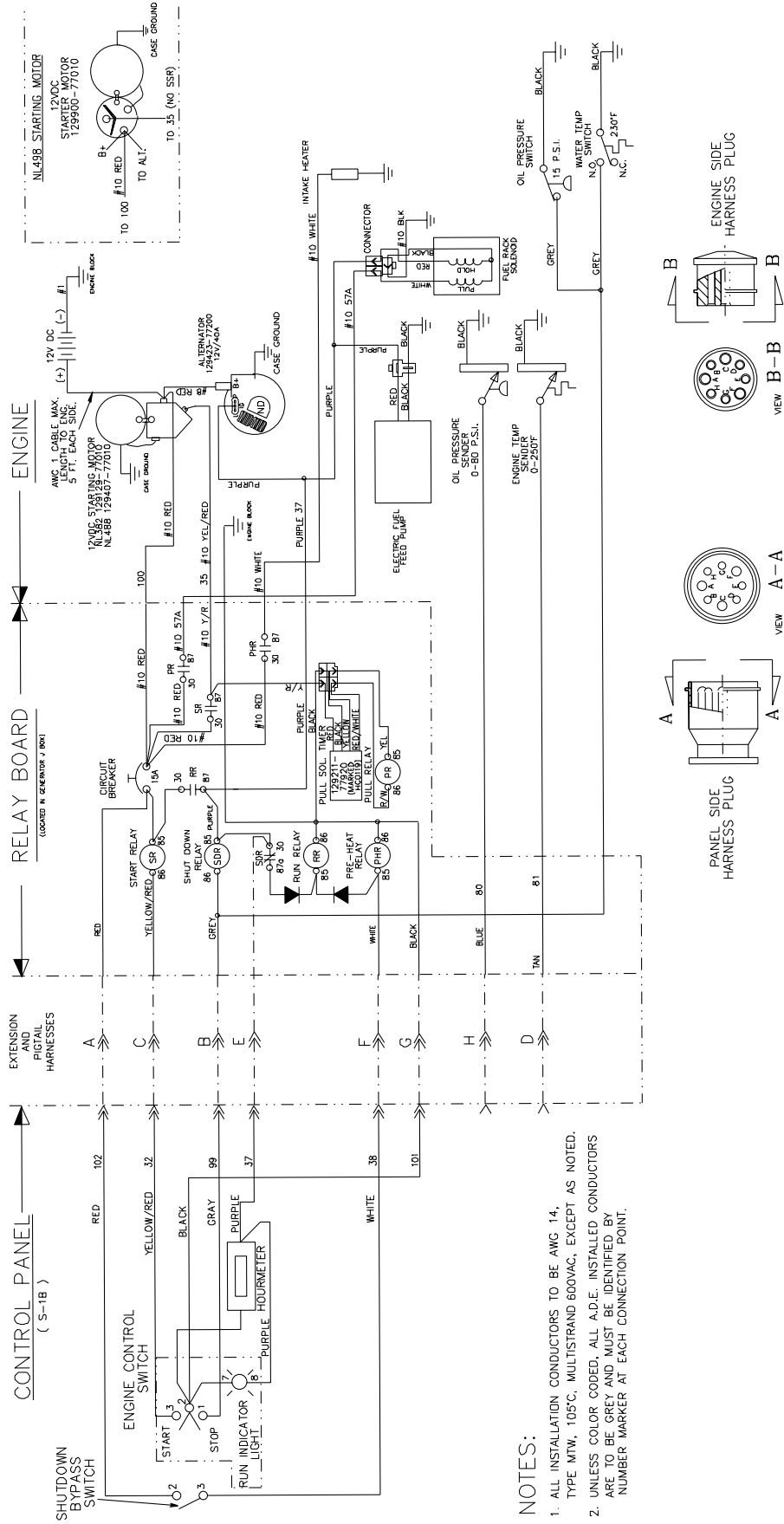

## NOTES:

1. ALL INSTALLATION CONDUCTORS TO BE AWG 14. TYPE MW, 105C, MULTISTRAND 600VAC, EXCEPT AS NOTED.
2. UNLESS COLOR CODED, ALL A.D.E. INSTALLED CONDUCTORS ARE TO BE GREY AND MUST BE IDENTIFIED BY NUMBER MARKER AT EACH CONNECTION POINT.

NL382W DC Wiring Diagram  
12 Volt Standard Ground  
B-8613