

**ONL843NW2**

For Model: NL843NW2

# OPERATOR'S MANUAL

Marine Generators | Marine Diesel Engines | Land-Based Generators



**LUGGER**





— CALIFORNIA —  
Proposition 65 Warning:

*Diesel engine exhaust and some of its constituents are known to the State of California to cause cancer, birth defects, and other reproductive harm.*

**Northern Lights**  
4420 14th Avenue N.W.  
Seattle, WA 98107  
Tel: (206) 789-3880  
Fax: (206) 782-5455

Copyright ©2009 Northern Lights, Inc.  
All rights reserved. Northern Lights™, and  
the Northern Lights logo are trademarks of  
Northern Lights, Inc.

Printed in U.S.A.  
PART NO.: ONL843NW2 10/09



# OPERATOR'S MANUAL

## for Model NL843NW2

*Read this operator's manual thoroughly before starting to operate your equipment.  
This manual contains information you will need to run and service your new unit.*

### Table of Contents

<b>INTRODUCTION</b> .....	<b>4</b>	<b>SERVICING (continued)</b>	
Models Included .....	4	V-Belts .....	13
Model Numbers .....	4	Valve Clearances .....	13
Serial Numbers .....	4	Fuels - General .....	14
<b>WARRANTY</b> .....	<b>5</b>	Fuel Filters .....	14
<b>SAFETY RULES</b> .....	<b>5</b>	Bleeding the Fuel System .....	15
<b>COMPONENT LOCATIONS</b>		Injector Service .....	16 - 17
NL843NW2 Industrial Generator .....	6	Injection Pump .....	17
<b>CONTROL PANELS</b>		Cooling System - General .....	17
Northern Lights Generator Sets .....	7	Cooling System Flushing .....	18
<b>OPERATING PROCEDURES</b>		Generator Ends .....	18
Break-in Period .....	8	Electrical System - General .....	18
Before Starting .....	8	Glow Plugs .....	18
Starting .....	8	Booster Batteries .....	19
Operating .....	8	Battery Care .....	19
Stopping .....	8	Winterizing / Out-of-Service .....	19
Shutdowns and Alarms .....	9	<b>TROUBLESHOOTING</b>	
Spare Parts .....	9	Electrical .....	20
<b>SERVICING SCHEDULE CHART</b> .....	<b>10</b>	Engine .....	21 - 23
<b>SERVICING</b>		<b>DATA SHEETS</b>	
Lubrication - General .....	12	NL843NW2 .....	24
Checking Oil .....	12	<b>WIRING DIAGRAMS</b>	
Oil Changes .....	12	AC Electrical .....	25
Changing Oil Filter .....	12	DC Electrical .....	26
Air Filter .....	13		

#### Proprietary Information

This publication is the property of Northern Lights, Inc.  
It may not be reproduced in whole or in part without the written permission of Northern Lights, Inc.  
© Northern Lights, Inc. All rights reserved. Litho U.S.A. Publication number ONL843NW2 10/09

## Introduction

Servicing of marine engines and generator sets presents unique problems. In many cases boats cannot be moved to a repair facility. Marine engines cannot be compared to the servicing of automobiles, trucks or even farm equipment. Failures often occur in remote areas far from competent assistance. Marine engines are taxed far more severely than auto or truck engines; therefore, maintenance schedules must be adhered to more strictly.

Failures can begin with minor problems that are overlooked and become amplified when not corrected during routine maintenance.

As operator, it is your obligation to learn about your equipment and its proper maintenance. This is not a comprehensive technical service manual. Nor will it make the reader into an expert mechanic. Its aim is to aid you in maintaining your unit properly.

## Unit Identification

### MODELS INCLUDED

This manual covers the operating instructions for:

**NL843NW2** industrial generator set

Fill in the model number of your unit in the blank space provided.

This will give you a reference whenever service or maintenance is required:

My Northern Lights generator set MODEL number is:

## Model Numbers

Model numbers give the unit's application, block model, aspiration, and RPM:

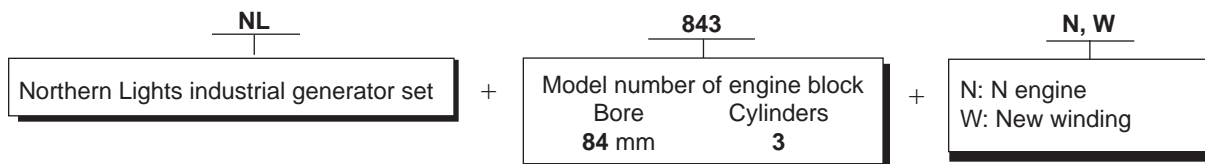

**NL843NW2** = Northern Lights industrial diesel generator set with an 843N engine and a PX-312K2 generator end.

## Serial Numbers



Your set has three serial numbers: ① an engine number stamped on the block, ② a generator plate, and ③ a generator set plate.

Use the serial number on the generator set plate when ordering parts or in correspondence. The generator set plate is found on the service side of the generator and resembles the drawing in Figure 1.

*Figure 1: Generator set serial number plate.*

A warranty registration certificate is supplied with your set. It entitles the original purchaser of our equipment to a warranty covering material or assembly faults. The extent of coverage is described in the Limited Warranty Statement. We recommend that you study the statement carefully.

**NOTE:** If the warranty is to apply, the servicing instructions outlined in this manual must be followed. If further information is needed, please contact an authorized dealer or the factory.

## Safety Rules



**CAUTION:** *Accident reports show that careless use of engines causes a high percentage of accidents.*

*You can avoid accidents by observing these safety rules. Study these rules carefully and enforce them on the job.*

- Never leave engine without proper security.
- Turn the coolant tank cap slowly to relieve pressure before removing. Add coolant only when the engine is stopped and cool.
- Mount a fire extinguisher near engine.
- Always disconnect the battery ground strap before making adjustments.
- Operate engines in properly ventilated areas.
- Keep trash and other objects away from engine.
- Escaping fluids under pressure can penetrate your skin. Use a piece of cardboard or wood, not your hands, to search for leaks.
- Avoid wearing loose clothing without a belt when working around engines.
- Do not oil or grease engine while it is running.
- Use caution in handling fuel. Never refuel a hot or running engine. Do not smoke while filling fuel tank or servicing fuel system.
- Keep your hands, feet, hair and clothing away from power-driven parts.
- Check for any loose electrical connections or faulty wiring.
- Engines should be operated only by knowledgeable, qualified personnel.
- Look completely around engine to make sure that everything is clear before starting.
- Do not operate an engine that isn't in proper working order. If an unsafe operating condition is noted, tag the set and control panel so others will also know about the problem.
- Provide first aid kits.



**CAUTION:** *This symbol is used throughout this book to alert you to possible danger areas. Please take special notice of these sections.*

## Industrial Generator Component Locations

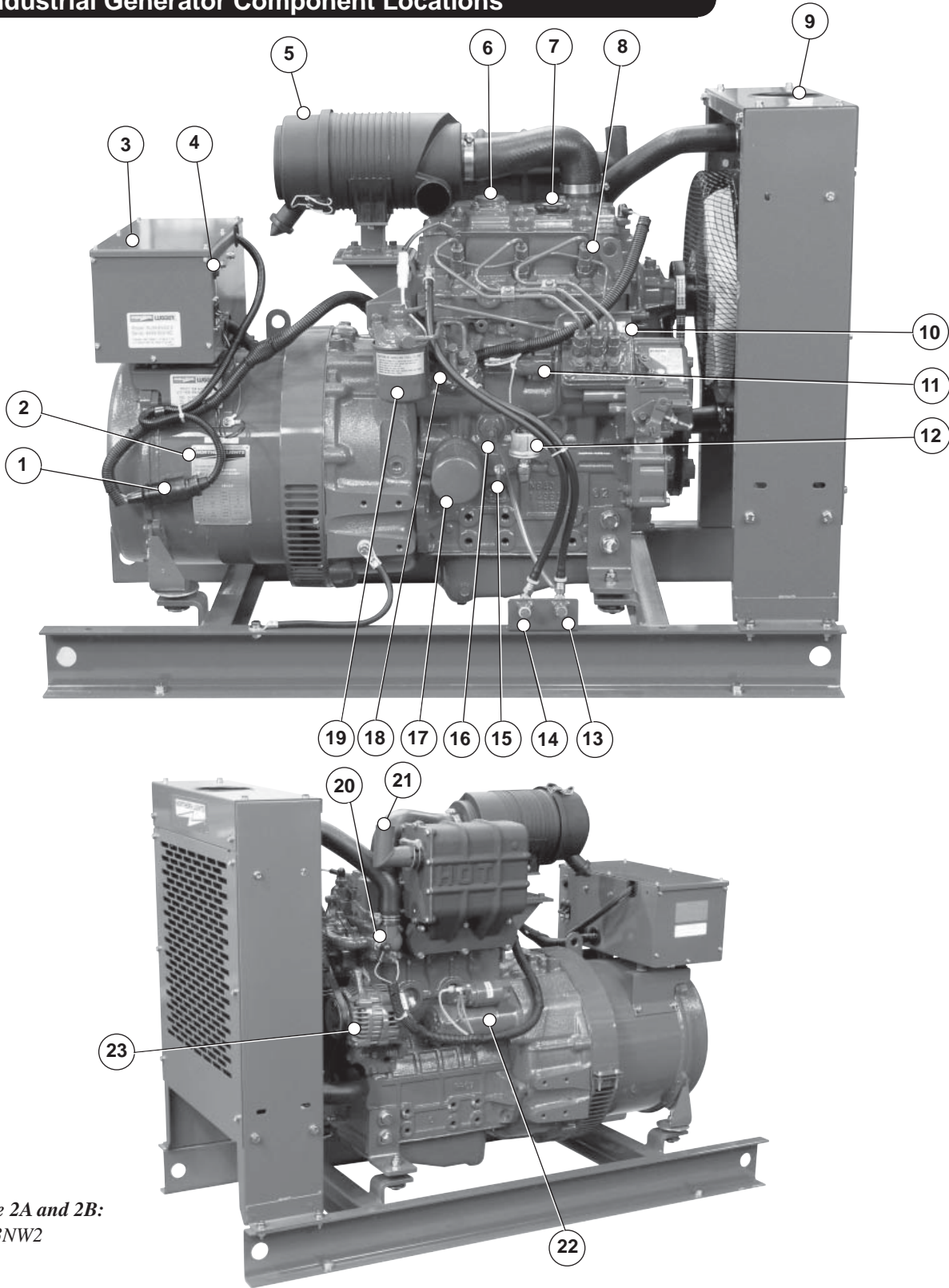

**Figure 2A and 2B:**  
NL843NW2

- |                           |                         |                      |                                |
|---------------------------|-------------------------|----------------------|--------------------------------|
| 1. Control Panel Plug-in  | 7. Oil Fill             | 13. Fuel Inlet Line  | 19. Fuel Filter                |
| 2. Generator Plate        | 8. Fuel Injector        | 14. Fuel Return Line | 20. Coolant Temperature Sender |
| 3. Generator Junction Box | 9. Coolant Fill         | 15. Oil Dipstick     | 21. Exhaust Outlet             |
| 4. DC Circuit Breaker     | 10. Injection Pump      | 16. Block Drain      | 22. Starter                    |
| 5. Air Filter             | 11. Shutdown Solenoid   | 17. Oil Filter       | 23. DC Alternator              |
| 6. Crankcase Vent         | 12. Oil Pressure Sender | 18. Fuel Lift Pump   |                                |



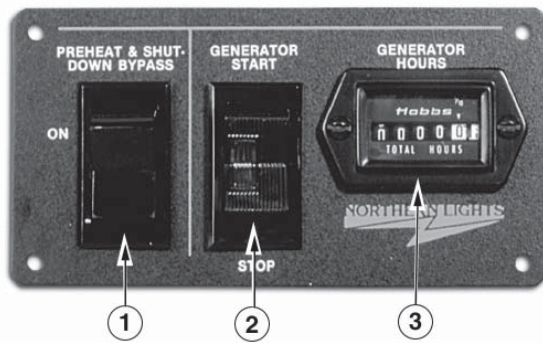

Figure 3-A: Series 1-B Generator Control Panel



Figure 3-B: Series 3 Generator Control Panel

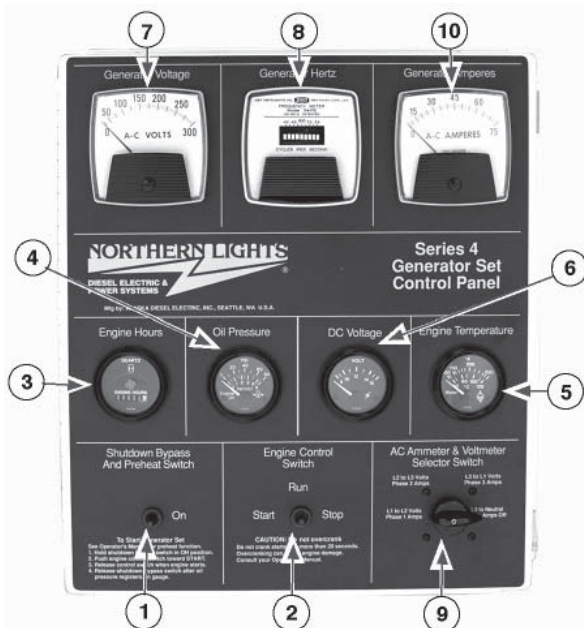

Figure 3-C: Series 4 Generator Control Panel

## 1. SHUTDOWN BYPASS-PREHEAT SWITCH

Two functions are built into this switch: the preheating of the engine, and bypassing of the engine safety shutdown circuit. Hold switch in the ON position 10 - 20 seconds before starting the engine, and continue holding on during engine cranking. Release the switch as soon as the engine is running. Holding the switch on too long can burn out the heater element.

## 2. ENGINE CONTROL SWITCH

To start the engine, hold this switch in the START position until the engine is running.

*NOTE: Excessive cranking of marine sets equipped with water lift muffler systems can cause engine damage. See page 10.*

After the engine starts, release the switch and it will return to RUN position. To stop the engine, hold the switch in the STOP position until the engine has completely stopped.

*NOTE: The rocker switch is used on Series 1 panels only, and has a light that glows when the set is running.*

## 3. HOUR METER

Keeps track of engine running time.

## 4. OIL PRESSURE GAUGE

Shows the oil pressure in the engine lubricating system.

## 5. ENGINE TEMPERATURE GAUGE

Registers the temperature of the engine coolant.

## 6. D.C. VOLTMETER OR AMMETER

When the engine is stopped, the voltmeter indicates the condition of the battery. When the engine is running, the voltmeter indicates the voltage output of the alternator.

## For Series 4 Control Panels Only:

### 7. A.C. VOLTMETER

Shows the generator output voltage.

### 8. FREQUENCY METER (Hertz)

The frequency meter indicates alternating current frequency: 60 Hz (1800 RPM), or 50 Hz (1500 RPM).

### 9. AMMETER/VOLTMETER SELECTOR SWITCH

Used to check voltage and current of each phase.

### 10. A.C. AMMETER

Shows the generator load on each phase. The phase is selected with the Ammeter Selector switch (Item 9).

## Operating Procedures

### BREAK-IN PERIOD

1. The first 100 hours on a new or reconditioned engine are critical to its life and performance.
2. Frequently check the engine temperature and oil pressure gauges (sets with Series 3 or 4 panels).
3. Oil consumption is greater during break-in as piston rings take time to seat.
4. Break-In Oil Changes: Change engine oil and filter at 50 hours. Change oil and filter again at 100 hours (consult Lubricants section for oil recommendation), then every 250 hours.

#### Operating Instructions:

Maintain at least a 75% load on your generator set for the first 100 hours. If this is not possible, maintain no less than a 50% load to ensure proper seating of the piston rings. Vary the load to help seat the rings.

### BEFORE STARTING

1. Check the water level by removing the pressure cap from the radiator. In order to give the cooling water an opportunity to expand, the level should be about 1 in. (2.5 cm) below the filler cap sealing surface when the engine is cold.



**CAUTION:** Use protective clothing and open the filler cap carefully when the engine is warm to prevent burns.

2. Check the oil level in the crankcase with the dipstick. The oil level must be in the waffled area on the stick. Never allow the level to go below this area. Always add the same viscosity of oil as is already in the crankcase.
3. Check the fuel tank level and open any fuel valves.
4. **NOTE:** The battery switch must always be kept ON while the engine is running. If the switch is turned OFF while the engine is running, the battery charging regulator could be ruined.

### STARTING

1. Hold the Shutdown Bypass-Preheat switch in the ON position for 10 to 20 seconds before starting a cold engine. Holding the switch too long can burn out the glow plugs. This step is not necessary if the engine is already warm.
2. While holding the Shutdown Bypass-Preheat switch in the ON position, push the Engine Control switch to the START position.
3. As soon as the engine starts, release both switches. Do not crank the starter for more than 20 seconds consecutively. If the engine fails to start with the first attempt, be sure that it has stopped completely before re-engaging.

### OPERATING

1. Units with Series 3 and Series 4 Control Panels: check gauges often. Oil pressure must be above 15 PSI. The D.C. voltmeter should read between 11 and 15 volts at 80°F (25°C) ambient temperature. Check the A.C. voltage and frequency meters (Series 4 panel). If the gauges deviate from normal levels, shut down the generator set and investigate.
2. Let the unit run unloaded for a three to five minute warm-up period.
3. Apply electrical load.

### STOPPING

1. Remove electrical load from the generator set.
2. Run the engine for a 3 to 5 minute cool down period.
3. Hold the Engine Control switch to the STOP position until the engine comes to a complete stop.



## SHUTDOWNS AND ALARMS

1. Your unit is fitted with a system to protect it from high water temperature or low oil pressure.
  - a. Generator sets have shutdown systems to stop the engine. They have no warning horns.
  - b. Other alarms and shutdowns are available as optional equipment.

**NOTE:** *Do not rely on your warning to the exclusion of careful gauge monitoring. Watching your gauges can prevent damage to the unit and dangerous power losses.*

2. Do the following when your warning or shutdown system is activated:
  - a. Check the temperature gauge. If above 205°F (96°C), shut off the engine immediately.
  - b. Use the Trouble Shooting Guide on page 20 to isolate the cause of the overheat.



**CAUTION:** *Do not remove the water fill cap of an overheated engine. Escaping high temperature steam can cause severe burns. Allow the engine to cool and then remove the cap slowly using protective clothing.*

- d. Make repairs. Restart your set after the temperature gauge registers below 200°F (94°C).
- e. Watch the temperature gauge regularly and turn off the unit if the temperature rises above 205°F (96°C). Repeat troubleshooting.
3. If shutdown is activated and the temperature gauge shows temperature within normal temperature range:
  - a. Check the engine crankcase oil level.
  - b. If the oil level is low, fill with recommended lubricating oil and restart. Watch the oil pressure gauge carefully and shut off the engine if it does not show a normal reading (20-60 PSI) after a few seconds of operation.
  - c. If the oil level is normal, DO NOT restart the engine. Call your dealer for assistance.

## SPARE PARTS

1. Northern Lights recommends that you keep the following spare parts on hand for field service. The parts are available from your local Northern Lights dealer.
 

Some marine models already have “On-Board-Kits,” a handy box that contains the most common parts you will need.
2. All owners should have the following spares:
  - a. Primary and secondary fuel filter elements
  - b. Oil filters
  - c. Air filter
  - d. Alternator belt
  - e. Thermostat and gaskets
  - f. Glow plug
  - g. Injector and washer
3. If your set is operating a long distance from a servicing dealer, add the following:
  - a. Complete set of injectors
  - b. Copper washers for injector change
  - c. Complete set of glow plugs
  - d. Fuel lift pump

## Servicing Schedule Chart

The Servicing Schedule Chart below shows the service schedule required for proper maintenance of your generator set. More detailed coverage of each Service Point (SP) is listed on the page noted in the 'page' column.

**DAILY:**

- SP1 Check oil level in engine
- SP5 Check V-belt tension
- SP7 Check primary fuel filter
- SP13 Check coolant level
- SP18 Check electrolyte in batteries

**AFTER FIRST 50 HOURS:**

- SP2/3 Change engine oil and filter
- SP6 Adjust valves

**AFTER FIRST 100 HOURS:**

- SP2/3 Change engine oil and filter

**EVERY 250 HOURS:**

- SP2/3 Change engine oil and filter
- SP4 Check air cleaner
- SP15 Check and clean radiator
- SP19 Check state of charge of batteries
- SP22 Inspect condition of exhaust system

**EVERY 500 HOURS:**

- SP8 Change primary fuel filter element
- SP9 Change secondary fuel filter

**EVERY 1000 HOURS:**

- SP6 Check valve clearances
- SP11 Check injectors

**EVERY 2500 HOURS:**

- SP12 Check fuel injection pump
- SP14 Check and flush cooling system

SERVICE POINT	PAGE	OPERATION	DAILY	50 Hours	250 Hours	500 Hours	1000 Hours	2500 Hours
<b>ENGINE:</b>								
SP1	12	Check oil level	•					
SP2	12	Change engine oil		•	•			
SP3	12	Change lube oil filters		•	•			
SP4	13	Check air cleaner			•			
SP5	13	Check V-belt tension	•					
SP6	13	Check valve clearances					•	
<b>FUEL SYSTEM:</b>								
SP7	14	Check primary filter (Racor)	•					
SP8	14	Change primary filter element (Racor)				•		
SP9	14	Change secondary fuel filter				•		
SP10	15	Bleed the fuel system						
SP11	17	Check injectors					•	
SP12	17	Check fuel injection pump						•
<b>COOLING SYSTEM:</b>								
SP13	17	Check coolant level	•					
SP14	18	Check and flush cooling system						•
SP15	18	Check and clean radiator fins			•			
<b>ELECTRICAL SYSTEM:</b>								
SP18	19	Check electrolyte level in batteries	•					
SP19	19	Check condition of batteries with hydrometer				•		
<b>OUT OF SERVICE:</b>								
SP21	19	Winterizing or out-of-service						

- 1) Perform all maintenance once a year even if hour level has not been reached.
- 2) Consult manufacturer's maintenance schedule, note on chart.
- 3) Whenever necessary.
- 4) More often if necessary.
- 5) After first 50 hours, then after the first 100 hours, then every 250 hours.

- 6) Clean injection nozzles every 1500 hours.
- 7) For EPA emission standards fuel nozzle needs to be cleaned every 1500 hours, the fuel nozzle and fuel pump need to be cleaned, adjusted, or repaired every 3000 hours, and the quality guarantee for these parts is 1500 hours or 2 years.



## Servicing

### LUBRICATION - GENERAL

1. Use only clean, high quality lubricants stored in clean containers in a protected area.
2. These lubricants are acceptable:
  - a. API Service CC/CD/CE single viscosity oils.
  - b. API Service CC/CD/SF multi-viscosity oils.
3. Use the proper weight oil for your average operation temperature.

Air Temperature	Single Viscosity	Multi-Viscosity
Above 32°F (0°C)	SAE 30W	SAE 15-40W
-10 to 32°F (-23 to 0°C)	SAE 10W	SAE 10-30W
Below -10°F (-23°C)	SAE 5W	SAE 5-20W

Figure 4: Lube Oils

4. Some increase in oil consumption may be expected when SAE 5W and SAE 5-20W oils are used. Check oil level frequently.
5. Never put additives or flushing oil in crankcase.

### SP1. CHECKING OIL LEVEL

1. Check the oil level in the crankcase with the dipstick. The oil level must be in the waffled area on the stick. Never allow the level to go below this area. Follow the lubrication recommendations above.

### SP2. OIL CHANGES

1. The set is delivered with special break-in oil. Change the engine oil and oil filter after 50 hours of operation. Use Service CC 30 weight oil during the first 100 hours.
2. Change the oil and filter again at 100 hours using the oil recommended in the above diagram. After this, change oil and filter every 250 hours.
3. During intermittent cold weather operation, change oil every 100 hours or six weeks, whichever comes first.
4. Change oil at the end of each season and the beginning of each season.
5. Change oil when engine is warm.
6. Dispose of waste oil in an approved manner.
7. Never use a flushing oil.
8. Loosen the clamp on the oil change tube. Remove cap. Drain oil. Replace the cap and tube.
9. Refill engine with recommended oil for the season.
10. Engine capacity with new oil filter is:  
**NL843NW2 – 1.6 gallons (6 liters)**

### SP3. CHANGING LUBE OIL FILTER

1. Change the lube oil filter every 250 hours.
2. Use a filter wrench to remove old filter. Dispose of filter in approved manner.
3. Make sure the gasket from the old filter is removed and discarded. Clean mount face.
4. Spread a thin film of engine oil on the rubber gasket on the new filter and screw it on nipple until gasket meets the sealing surface.
5. Using hands only – no wrench – tighten filter one-half turn farther. Overtightening can do damage to filter housing.
6. Fill engine with recommended oil. Start engine and check for leakage. Stop engine, wait 3 minutes, and check oil level. Add additional oil if necessary.
7. Oil filter part number is:  
**NL843NW2 – #140517020**

## SP4. AIR CLEANER

1. Inspect air cleaner every 250 hours. In dusty conditions, check more often.
2. Replace if necessary. Part number is:  
**NL843NW2 (ELEMENT ONLY) – #24-27302**
3. **NOTE: Make absolutely sure no impurities enter the engine while changing the element. Do NOT run the engine with the air cleaner removed.**

## SP5. V-BELTS

1. Check the tension and wear on the V-belt daily.
2. Use your thumb to press on the belt at the midpoint between the crankshaft and alternator pulleys. The tension is correct if the belt can be depressed about 3/16 in. (5 mm). Fan belt slackness should be about 3/16 in. (5 mm).
3. To adjust the belt tension loosen the alternator adjusting plate bolt and the alternator mounting bolt. Pivot the alternator at the mounting bolt as needed.
4. Tighten the mounting bolt and the adjusting bolt.
5. Operate engine at low idle speed and recheck the belt tension.

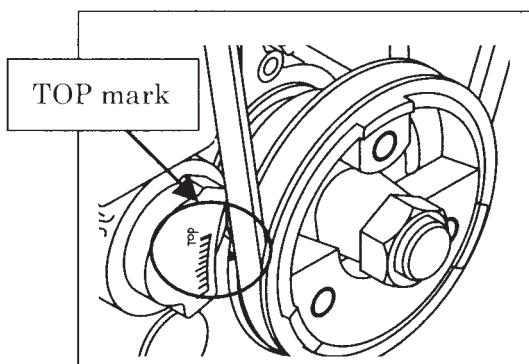

**Figure 5:** Timing mark

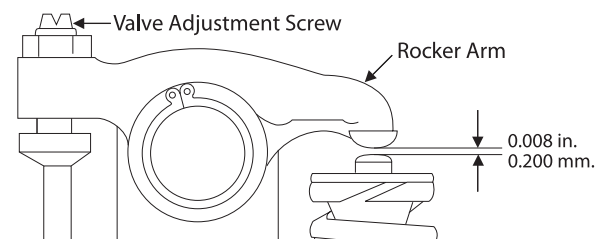

**Figure 6:** Valve Adjustment

## SP6. VALVE CLEARANCES

1. Adjust valve clearance after 1000 hours, or as needed.
2. Valve adjustments should be done after the cylinder head bolts have been re-tightened. Engine should be cold and NOT running.
3. Watch the valves while turning the engine over by hand. Turn until the inlet valve starts to open and the exhaust valve starts to close (the valves are rocking). Then turn the crankshaft one more full turn and adjust the clearance on both valves for this cylinder. Align the top mark of the crank pulley with the TOP mark of the timing gear case.
4. Loosen the lock nut and adjust the clearance between the rocker arm and valve guide of both the intake and exhaust valves with the adjustment screw (Figure 6). Clearance on both intake and exhaust valves should be 0.008 in. (0.2 mm).
5. Repeat steps 3 and 4 for each cylinder. Each set of valves must be adjusted individually.
6. Replace the rocker arm cover. Tighten cover nuts to 5 - 8 ft/lbs (0.8 - 2.3 kg/m).

Cylinder	No. 1		No. 2		No. 3	
	In	Ex	In	Ex	In	Ex
When No. 1 cyl. is at TDC in compression stroke	○	○		○		
With the crankshaft turned by 360° in normal direction from above			○		○	○

**Figure 7:** 843NW2 Valve sequence

## Servicing

### FUELS - GENERAL

1. Use only clean, high quality fuels of the following specifications, as defined by ASTM designation D975 for diesel fuels:
  - a. Use grade no. 2 diesel at ambient temperatures above freezing 32°F (0°C).
  - b. Use grade no. 1 at ambient temperatures below freezing and for all temperatures at an altitude of above 5,500 ft. (1500 meters).
2. Use fuel having less than 1% sulphur (preferably less than 0.5%).
3. The cetane number should be a minimum of 45.
4. **DO NOT** use these unsuitable grades of fuel:
  - a. Domestic heating oils, all types.
  - b. Class B engine.
  - c. Class D domestic fuels.
  - d. Class E, F, G or H industrial or marine fuels.
  - e. ASTM-D975-60T No. 4-D and higher number fuels.
5. Storing fuel:
  - a. Keep dirt, scale, water, and other foreign matter out of fuel.
  - b. Avoid storing fuel for long periods of time.
  - c. Fill the fuel tank at the end of each day's operation. This will reduce condensation and possible biological contamination.
  - d. If biological contamination is detected or suspected, contact your dealer for assistance.

### SP7-9. FUEL FILTERS



*Figure 8: Primary Fuel Filter (if provided by Northern Lights)*

1. Your generator set may have a primary fuel filter installed. We recommend the Racor brand of fuel filter-water separators.
  - a. Check the primary fuel filter daily as recommended by the filter manufacturer. Empty the collection bowl as necessary.
  - b. Change the element as often as necessary or every 500 hours.
  - c. If the bowl fills with water, change the primary and secondary element immediately.
2. Change secondary fuel filter every 500 hours.

*NOTE: The fuel filter on the engine is considered the "secondary fuel filter."*

  - a. Remove the spin-on filter by turning it counterclockwise with a filter wrench. Fill the new cartridge with fuel and install it after applying engine oil to gasket surface. Screw on until the gasket surface comes into contact with sealing surface of filter base. Then, tighten it two-thirds of a turn by hand. Do not overtighten.
  - b. Secondary fuel filter cartridge part number is:  
**NL843NW2 - #24-52020**



**SP10. BLEEDING THE FUEL SYSTEM**



**CAUTION:** Escaping diesel fuel under pressure can penetrate skin causing serious personal injury. Before disconnecting lines be sure to relieve all pressure. Before applying pressure, be sure all connections are tight and lines, pipes and hoses are not damaged. Fuel escaping from a very small hole can be almost invisible. Use a piece of cardboard or wood, rather than hands, to search for suspected leaks. If injured by escaping fuel, see a doctor at once. Serious infection or reaction can develop if proper medical treatment is not administered immediately.

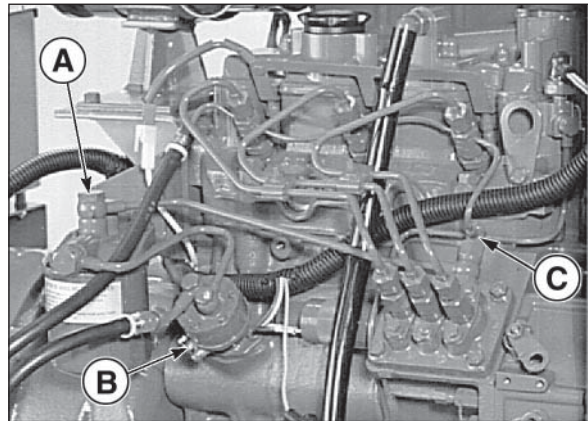
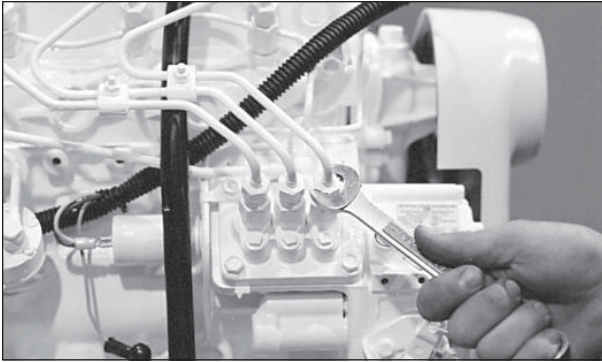

*Figure 9: NL843NW2 Fuel System (for illustration purposes).*

1. The fuel system is self-bleeding. However, any system may need manual bleeding when:
  - a. A new fuel filter is installed;
  - b. The engine has run out of fuel;
  - c. The fuel lines, injection pump or any other fuel system component has been removed and installed.
2. Loosen bleed bolt “A” (Figure 9) on top of the filter. Pump hand primer “B” on fuel lift pump until pure fuel (no bubbles) escapes from bleed bolt “A”. Tighten bleed screw “A”.
3. Loosen bleed screw “C”. Pump hand primer “B” until pure fuel (no bubbles) escapes. Then tighten bleed screw “C”.
4. If the engine does not start after the above bleeding process, loosen a fuel line at the injector while cranking the engine with the starter motor until pure fuel escapes. Then tighten the connection. Do each line **one-at-a-time**.
5. After the engine has started, use a piece of cardboard to look for fuel leaks.

## Servicing

*Figures 10-17: For illustrative purposes only, may not be exact model.*



**Figure 10:** Remove delivery line flare nuts.



**Figure 14:** Remove return line.

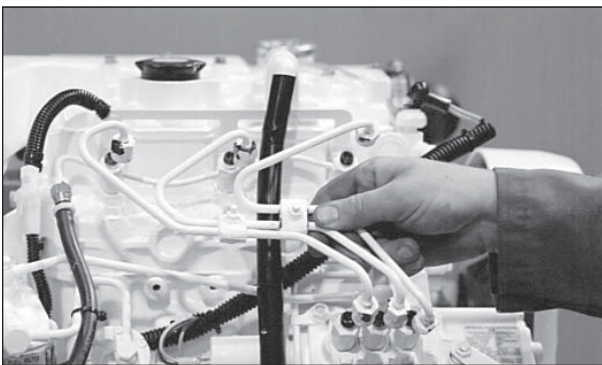

**Figure 11:** Remove delivery lines.

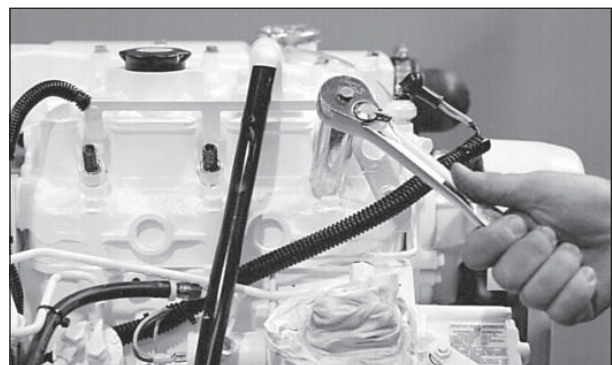

**Figure 15:** Unscrew injector.



**Figure 12:** Cover lines, inlets and injection pump outlets.



**Figure 16:** Remove and replace copper sealing washer.

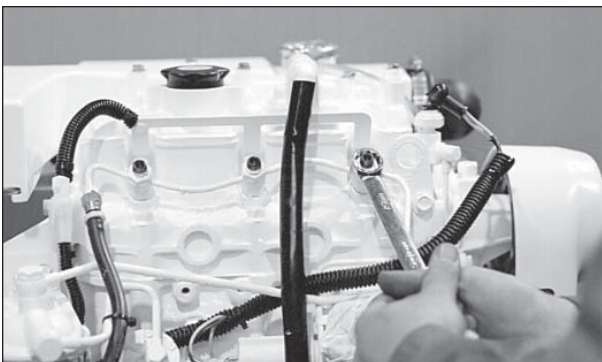

**Figure 13:** Remove return line nuts.



**Figure 17:** Reinstall injector. Torque to proper tightness.

## SP11. INJECTOR SERVICE

1. Injectors should be checked every 1000 hours. Check should be made by a Northern Lights dealer or local injection repair station.



**CAUTION:** Escaping diesel fuel under pressure can have sufficient force to penetrate the skin causing serious personal injury. If injured by escaping diesel fuel, see a doctor at once.

### 2. Injector removal:

- a. Clean loose dirt from around the injectors and the fuel lines.
- b. Relieve high pressure in the fuel lines by loosening the delivery line flare nuts at each injector (Figure 10).
- c. Remove delivery lines by disconnecting from injectors and injection pump (Figure 11). Remove all lines as an assembly; do not remove the spacers. Cover the ends of the lines, the injector inlets and injection pump outlets to keep dirt out (Figure 12).
- d. Remove the return line retaining bolts (Figure 13). Remove the return line (Figure 14).
- e. Unscrew and remove the injectors (Figure 15).  
**NOTE:** Do not use pry bars to remove injectors from cylinder head.
- f. After removing the injectors, discard the copper sealing washers from the injector hole in the head (Figure 16). Cover holes to prevent dirt and debris from entering the cylinders.

### 3. Injector installation:

- a. Install a new copper sealing washer in each injector hole (Figure 16).
- b. Screw in injector and tighten to 44 - 51 ft/lbs (6 to 7 kgm) (Figure 17).  
**NOTE:** Overtightening can damage injector.
- c. Install return line using a new sealing washer below each connection. Tighten return line retaining bolts to 22 - 30 ft/lbs.
- d. Install delivery lines. Leave loose at injectors for bleeding.
- e. Crank engine to fill lines. Tighten lines at injectors to 11-18 ft./lbs. Start engine and check for leaks using a piece of paper or cardboard.

**DO NOT use hand to check for leaks.**

## SP12. INJECTION PUMP

1. Since operating conditions may vary considerably, it is difficult to give a definite interval for checking the injection pump. But as a rule, pump settings, maximum speed, idle speed, and exhaust smoke should be checked after every 2500 hours of operation. Service of the fuel injection pump should only be done if checks indicate pump malfunction.
2. Black smoke can be an indication of pump malfunction. Before servicing the pump, check other possible causes:
  - a. Check cleanliness of air filter.
  - b. Check valve clearances.
  - c. Clean and check injectors.
3. Any repair which involves disassembly of the injection pump must be carried out by specially trained mechanics with the proper tools and test equipment.

**NOTE:** All warranties on the engine become null and void if the injection pump seals are broken by unauthorized persons.

## COOLING SYSTEM - GENERAL



**CAUTION:** The cooling water in the engine reaches extremely high temperatures. You must use extreme caution when working on hot engines to avoid burns. Allow the engine to cool before working on the cooling system. Open the filler cap carefully, using protective clothing when the engine is warm.

## SP13. CHECK THE COOLANT LEVEL

1. Check the coolant level each day before starting the engine. Check the water level by removing the pressure cap from the radiator. In order to give the cooling water an opportunity to expand, the level should be about 1 in. (2.5 cm) below the filler cap sealing surface when the engine is cold.
2. The pressure valve in the filler cap releases when the pressure is approximately 7 PSI (0.5 bar). Use a cap pressure tester to check cap if you suspect it is faulty.



### SP14. COOLING SYSTEM FLUSHING

1. Flush the cooling system every 2500 hours or every 12 months, whichever comes first.
2. Industrial sets:
  - a. Remove radiator cap and drain engine block.
  - b. Pour clean water into radiator until water coming from radiator is free of discoloration and sediment.
  - c. Close the radiator drain and continue flushing until water from the engine drain is clear.
  - d. Open all drain cocks and drain completely.
  - e. Close drain cock and refill with recommended mixture.
  - f. Clean leaves, dust, and other debris off the radiator fins.
3. Coolant Specifications:

Use 50% distilled water / 50% ethylene glycol anti-freeze mix. Antifreeze mixture is recommended as a good year-round coolant.
4. Check hoses and connections and repair any leakage.

### SP15. CLEAN RADIATOR

1. Remove debris from radiator fins daily.
2. In very dusty applications, clean the radiator with compressed air or steam cleaner every 100 hours. and check for leaks.

### GENERATOR ENDS

The maintenance and operation recommendations for the generator end are in a separate Owner's Manual. If you do not have one of these manuals, contact your local Northern Lights dealer.

### ELECTRICAL SYSTEM - GENERAL

1. Never switch battery switch off or break the circuit between the alternator and batteries while the engine is running. Regulator damage can result.
2. Do NOT reverse the polarity of battery cables when installing the battery.
3. If welding on the unit, disconnect the regulator and battery. Isolate the leads.
4. Disconnect the battery cables when servicing the D.C. alternator.
5. Never test with a screwdriver, etc., against any terminal to see if it emits sparks.
6. Do not polarize the alternator or regulator.
7. A D.C. circuit breaker protects your control panel and wiring harness. It is located in the side of the generator junction box.

### GLOW PLUGS

1. Each cylinder is supplied with a glow plug which serves to heat the combustion chamber.
2. To check the glow plugs, loosen the current carrying flat wire between the plus-poles of the glow plugs (Figure 18). Connect a D.C. test bulb between the plus-pole of the battery and the plus-pole of the glow plug. If the bulb lights up, the glow plug is functioning properly.
3. Check all glow plugs and replace any faulty ones.

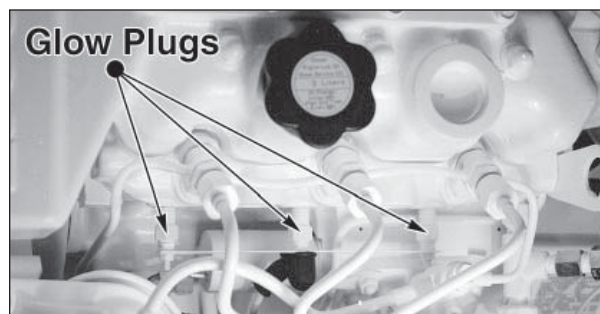

*Figure 18: Glow plugs.*

## BOOSTER BATTERIES



**CAUTION:** *Battery gas can explode. Keep all flames and sparks away from batteries.*

1. Before changing or using booster batteries, check battery electrolyte level. Add distilled water if necessary.
2. Booster and main batteries must have the same voltage rating.
3. First, connect positive (+) terminal of booster battery to positive (+) terminal of main battery. Then, connect negative (-) terminal of booster battery to ground on the engine block (see Figure 19).
4. Remove booster battery after starting engine.
5. Sealed batteries: See manufacturer charging and booster instructions.

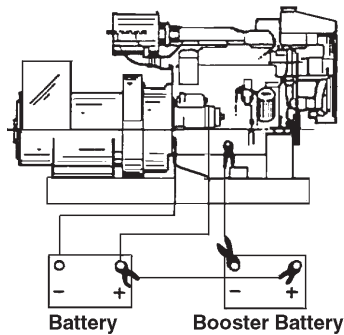

**Figure 19:**  
*Battery connections.*

## SP 18-19. BATTERY CARE

1. Check electrolyte level daily. Add distilled water to manufacturer's recommended level.
2. Batteries, cables and cable terminals should be checked and cleaned every 100 hours. Clean corrosion with a water and baking soda solution. Flush with clean water. Tighten terminals and grease them to inhibit corrosion.
3. Check the battery condition with a hydrometer every 250 hours.

## SP21. WINTERIZING / OUT-OF-SERVICE

1. Industrial sets:
  - a. Drain and flush the radiator and cooling system. Refill with antifreeze-water mixture. Start the engine and run to circulate the antifreeze.
  - b. Fill the fuel tank or add biocide as per the manufacturer's instructions.
  - c. Change the crankcase oil and filter.
  - d. Seal the air cleaner inlet, exhaust opening, crankcase breather pipe, and fuel tank vent with plastic bags and tape.
  - e. Loosen the alternator belt.
  - f. Disconnect and clean battery. Remove to warm storage place if possible.
  - g. Clean outside of unit. Paint any scratched or chipped surfaces. Put corrosion preventative on all exposed metal surfaces.
  - h. Store the set in a dry, protected place. If the unit must be stored outside, be sure it is well protected with a cover.

## Troubleshooting

### DC ELECTRICAL SYSTEM

PROBLEM	POSSIBLE CAUSE	RECOMMENDATION(S)
<b>Battery Will Not Charge</b>	Loose or corroded connections	• Clean and tighten battery connections.
	Sulfated or worn out batteries	• Check specific gravity of each battery. • Check electrolyte level of each battery.
	Loose or defective alternator belt	• Adjust belt tension. • Replace belt.
<b>Starter Inoperative</b>	Check DC circuit breaker	• If the breaker is tripped, reset it.
	Loose or corroded connections	• Clean and tighten loose battery and harness plug connection.
	Low battery output	• Check specific gravity of each battery. • Check electrolyte level of each battery.
	Defective electrical system ground wire:	• Repair or replace.
<b>Starter Cranks Slowly</b>	Low battery output	• Battery is too small. • Battery cables are too small.
	Check specific gravity of each battery	• Replace battery if necessary.
	Check electrolyte level of each battery	• If low, fill cells with distilled water.
	Crankcase oil too heavy	• Fill with oil of appropriate viscosity.
	Loose or corroded connections	• Clean and tighten loose connections.
<b>Entire Electrical System Does Not Function</b>	Check DC circuit breaker	• If breaker is tripped, reset it.
	Faulty connection	• Clean and tighten battery and harness plug connections.
	Sulfated or worn out batteries	• Check specific gravity and electrolyte level of each battery.

If you cannot correct problems with these procedures, see your **Northern Lights** dealer.



### ENGINE

PROBLEM	POSSIBLE CAUSE	RECOMMENDATION(S)
<b>Engine Hard to Start or Will Not Start</b>	Improper starting procedure	<ul style="list-style-type: none"> <li>• See starting section of this manual. Take special note of Bypass Switch operation.</li> </ul>
	No fuel	<ul style="list-style-type: none"> <li>• Check level of fuel in fuel tank.</li> </ul>
	Low battery output	<ul style="list-style-type: none"> <li>• Check electrolyte level and condition.</li> </ul>
	Excessive resistance in starting circuit	<ul style="list-style-type: none"> <li>• Clean and tighten all battery connections.</li> </ul>
	Crankcase oil too heavy	<ul style="list-style-type: none"> <li>• Use oil of proper viscosity.</li> </ul>
	Improper type of fuel	<ul style="list-style-type: none"> <li>• Consult fuel supplier and use proper type of fuel for operating condition.</li> </ul>
	Water, dirt or air in fuel system	<ul style="list-style-type: none"> <li>• Drain, flush, fill and bleed system.</li> </ul>
	Clogged primary fuel filter element	<ul style="list-style-type: none"> <li>• Clean or replace filter element.</li> </ul>
	Clogged secondary fuel filter element	<ul style="list-style-type: none"> <li>• Replace filter element.</li> </ul>
	Dirty or faulty injection nozzles	<ul style="list-style-type: none"> <li>• Have your dealer check injection nozzles.</li> </ul>
<b>Engine Runs Irregularly or Stalls Frequently</b>	Below normal engine temperature	<ul style="list-style-type: none"> <li>• Remove and check thermostat.</li> </ul>
	Clogged primary fuel filter element	<ul style="list-style-type: none"> <li>• Clean or replace filter element.</li> </ul>
	Clogged secondary fuel filter element	<ul style="list-style-type: none"> <li>• Replace secondary filter element.</li> </ul>
	Water or dirt in the fuel system	<ul style="list-style-type: none"> <li>• Drain, flush, fill and bleed system.</li> </ul>
	Dirty or faulty injection nozzles	<ul style="list-style-type: none"> <li>• Have your dealer check injection nozzles.</li> </ul>
	Air in fuel system	<ul style="list-style-type: none"> <li>• Inspect clamps and hoses on suction side of fuel pump for air leak.</li> </ul>
	Improper type of fuel	<ul style="list-style-type: none"> <li>• Consult fuel supplier and use proper type of fuel for operating condition.</li> </ul>
<b>Lack of Engine Power</b>	Intake air restriction	<ul style="list-style-type: none"> <li>• Service air cleaner.</li> </ul>
	Clogged primary fuel filter element	<ul style="list-style-type: none"> <li>• Clean or replace filter element.</li> </ul>
	Clogged secondary fuel filter element	<ul style="list-style-type: none"> <li>• Replace filter element.</li> </ul>
	Improper type of fuel	<ul style="list-style-type: none"> <li>• Consult fuel supplier and use proper type of fuel for operating conditions.</li> </ul>
	Overheated engine	<ul style="list-style-type: none"> <li>• See “Engine Overheats” in next category.</li> </ul>
	Below normal engine temperature	<ul style="list-style-type: none"> <li>• Remove and check thermostat.</li> </ul>
	Improper valve clearance	<ul style="list-style-type: none"> <li>• Reset valves. Best done by dealer.</li> </ul>
	Dirty or faulty injection nozzles	<ul style="list-style-type: none"> <li>• Replace injectors. Best done by dealer.</li> <li>• See your local dealer.</li> </ul>

## Troubleshooting

### ENGINE

PROBLEM	POSSIBLE CAUSE	RECOMMENDATION(S)
<b>Engine Overheats</b>	Low coolant level	<ul style="list-style-type: none"> <li>• Fill tank or radiator to proper level.</li> <li>• Check hoses for loose connections and leaks.</li> </ul>
	Cooling system needs flushing	<ul style="list-style-type: none"> <li>• Flush cooling system.</li> </ul>
	Defective thermostat	<ul style="list-style-type: none"> <li>• Remove and check thermostat.</li> </ul>
	Defective temperature gauge	<ul style="list-style-type: none"> <li>• Check water temperature with thermometer and replace gauge if necessary.</li> </ul>
<b>Engine Knocks</b>	Insufficient oil	<ul style="list-style-type: none"> <li>• Call your dealer.</li> </ul>
	Injection pump out of time	<ul style="list-style-type: none"> <li>• Call your dealer.</li> </ul>
	Below normal engine temperature	<ul style="list-style-type: none"> <li>• Check your thermostats.</li> <li>• Check water temperature to see if temperature gauge is working properly.</li> </ul>
	Engine overheating	<ul style="list-style-type: none"> <li>• See “Engine Overheating” section.</li> </ul>
<b>High Fuel Consumption</b>	Improper type of fuel	<ul style="list-style-type: none"> <li>• Use correct fuel for temperature.</li> </ul>
	Clogged or dirty air cleaner	<ul style="list-style-type: none"> <li>• Service air cleaner.</li> </ul>
	Improper valve clearance	<ul style="list-style-type: none"> <li>• See your dealer.</li> </ul>
	Injection nozzles dirty	<ul style="list-style-type: none"> <li>• See your dealer.</li> </ul>
	Injection pump timing off	<ul style="list-style-type: none"> <li>• See your dealer.</li> </ul>
	Engine not at proper temperature	<ul style="list-style-type: none"> <li>• Check your thermostats.</li> <li>• Check water temperature with thermometer and replace gauge if necessary.</li> </ul>
<b>Below Normal Engine Temperature</b>	Thermostat not working properly	<ul style="list-style-type: none"> <li>• Check thermostat.</li> </ul>
	Temperature gauge not working properly	<ul style="list-style-type: none"> <li>• Check water temperature with thermometer.</li> </ul>
<b>Low Oil Pressure</b>	Low oil level	<ul style="list-style-type: none"> <li>• Fill crankcase to proper level.</li> </ul>
	Improper type of oil	<ul style="list-style-type: none"> <li>• Drain and fill crankcase with correct oil.</li> </ul>
	Partially plugged oil filter	<ul style="list-style-type: none"> <li>• Replace filter.</li> </ul>
<b>High Oil Consumption</b>	Break-in period	<ul style="list-style-type: none"> <li>• Oil consumption decreases after break in.</li> </ul>
	Crankcase oil too light	<ul style="list-style-type: none"> <li>• Use proper viscosity oil.</li> </ul>
	Oil leaks	<ul style="list-style-type: none"> <li>• Check for leaks in lines around gaskets and drain plug.</li> </ul>

If you cannot correct problems with these procedures, see your **Northern Lights** dealer.

### ENGINE

PROBLEM	POSSIBLE CAUSE	RECOMMENDATION(S)
<b>Engine Emits Black or Gray Exhaust Smoke</b>	Clogged or dirty air cleaner	• Service air cleaner.
	Defective muffler (back pressure too high)	• Have dealer check back pressure.
	Improper fuel	• Use correct fuel for temperature.
	Injection nozzles dirty	• See your dealer.
	Engine timing off	• See your dealer.
<b>Engine Emits White Smoke</b>	Improper fuel	• Use correct fuel for temperature.
	Cold engine	• Warm up engine to normal operating temperature.
	Defective thermostat	• Remove and check thermostat.
	Engine timing off	• See your dealer.

If you cannot correct problems with these procedures, see your **Northern Lights** dealer.

## NL843NW2 Data

### NL843NW2

<b>Kilowatt Rating Prime Rated RPM/Frequency</b>	<b>12 kW 1800/ 60Hz</b>	<b>10 kW 1500/ 50 Hz</b>
<b>General Information</b>		
Engine Type	Lugger 4 cycle, swirl chamber diesel	
Cylinders	Inline 3	
Displacement	101.4 in <sup>3</sup> (1.662 liters)	
Cycles	4	
Bore x Stroke	3.3 x 3.9 in (84 x 100 mm)	
Rotation (Facing Flywheel)	counter-clockwise	
Compression Ratio	22:5	
Crankcase Capacity including Oil Filter	1.6 gal (6.0 liter)	
Aspiration	Natural	
Rated Horsepower	20.1 Hp	16.6 Hp
Approximate Dry Weight	757 lbs. (343 kg)	
Length	43 in (1092 mm)	
Width	22 in (559 mm)	
Height	33.13 in (842 mm)	
Approx. Coolant Capacity	1.1 gal (4 liters)	
Approx. Coolant Capacity (engine only)	.74 gal (2.8 liters)	
Standard Output, Single Phase	120-240 Volts, 50 Amps	220 Volts, 45.2 Amps
Compression Pressure of Cylinder MPa (kgf/cm <sup>2</sup> )	Standard Value: More than 2.94 MPa (more than 30 kgf/cm <sup>2</sup> ) Time to be repaired: Less than 2.45 MPa (less than 25 kgf/cm <sup>2</sup> )	
Cylinder Head Tightening Torque N•m (kgf/cm <sup>2</sup> )	98 - 103 N•m (10.0- 10.5 kgf/cm <sup>2</sup> )	

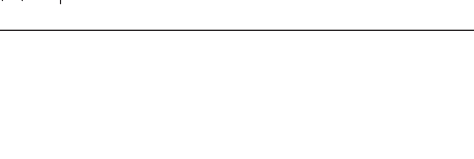
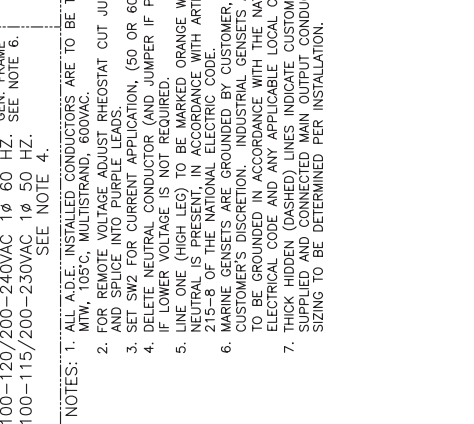
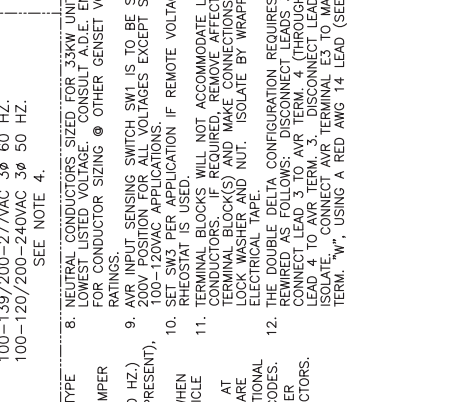
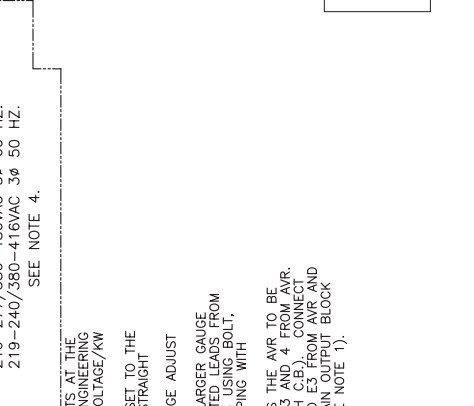
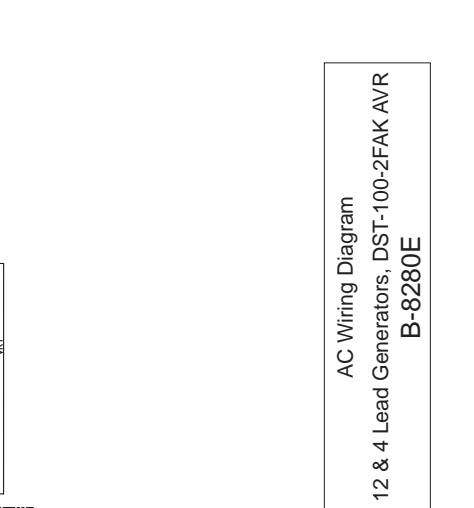
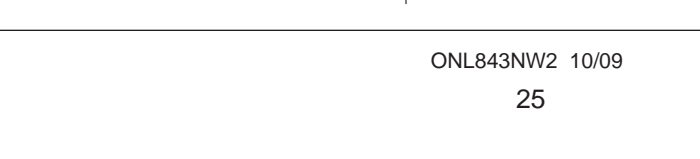
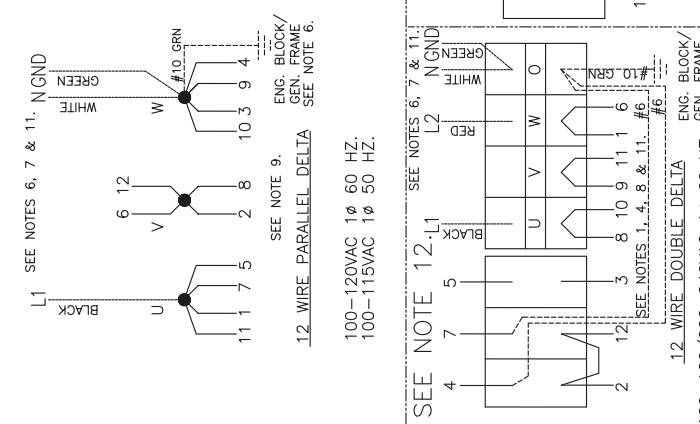
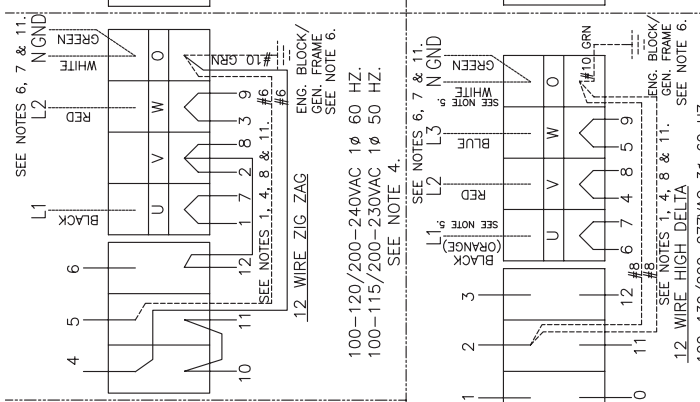
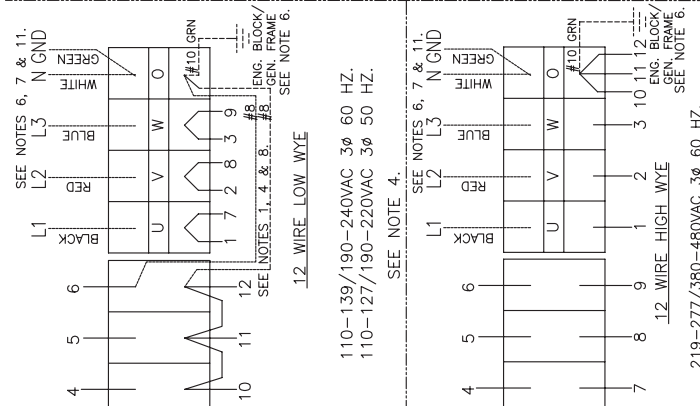
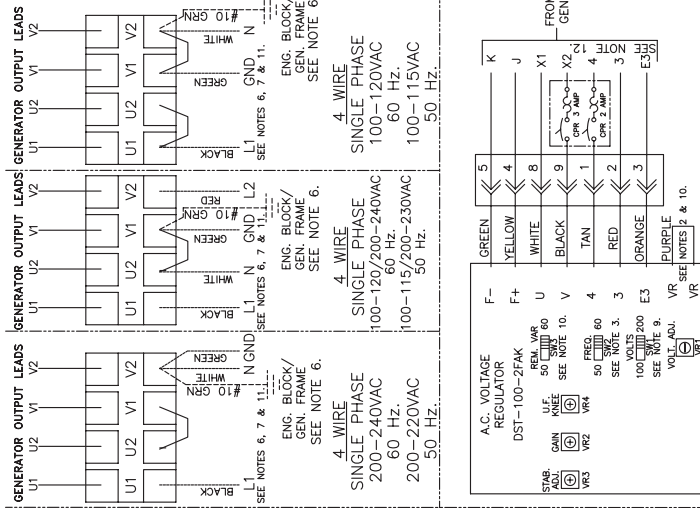

NOTES: 1. ALL A.D.E. INSTALLED CONDUCTORS ARE TO BE TYPE MW, 105°C, MULTISTRAND, 600VAC.  
 2. FOR REMOTE VOLTAGE ADJUST, RHEOSTAT CUT JUMPER IS TO BE USED.  
 3. SET SW3 FOR CURRENT APPLICATION, (50 OR 60 HZ).  
 4. DELETE NEUTRAL CONDUCTOR (AND JUMPER IF PRESENT), IF LOWER VOLTAGE IS NOT REQUIRED.  
 5. LINE ONE (PHASE LEG) TO BE ORANGE WHEN NEUTRAL (PHASE LEG) IS NOT REQUIRED.  
 6. CUSTOMER'S DISCRETION. INDUSTRIAL CUSTOMERS AT ELECTRICAL CODE AND ANY APPLICABLE LOCAL CODES. TO BE GROUNDED IN ACCORDANCE WITH THE NATIONAL ELECTRICAL CODE AND ANY APPLICABLE LOCAL CODES.  
 7. THICK HIDDEN (DASHED) LINES INDICATE CUSTOMER SUPPLIED AND CONNECTED MAIN OUTPUT CONDUCTORS. SIZING TO BE DETERMINED PER INSTALLATION.  
 8. NEUTRAL CONDUCTORS SIZED FOR 3XKW UNITS AT THE LOWEST LINE VOLTAGE. CONSULT ELECTRICAL ENGINEERING FOR CONDUCTOR SIZING @ OTHER GENSET VOLTAGE/KW RATINGS.  
 9. AVR INPUT SENSING SWITCH SW1 IS TO BE SET TO THE 200V POSITION FOR ALL VOLTAGES EXCEPT STRAIGHT 100-120VAC APPLICATIONS.  
 10. SET SW3 PER APPLICATION IF REMOTE VOLTAGE ADJUST RHEOSTAT IS USED.  
 11. TERMINAL BLOCKS WILL NOT ACCOMMODATE LARGER GAUGE CONDUCTORS. REMOVE AFFECTED LEADS FROM CONDUCTOR BLOCKS AND MAKE CONNECTIONS WITH BUSH, LOCK WASHER AND NUT. ISOLATE BY WRAPPING WITH ELECTRICAL TAPE.  
 12. THE DOUBLE DELTA CONFIGURATION REQUIRES THE AVR TO BE REWIRED AS FOLLOWS: DISCONNECT LEADS 3 AND 4 FROM AVR. CONNECT LEAD 3 TO AVR TERM. 4 (THROUGH C.B.). CONNECT LEAD 4 TO AVR TERM. 3. DISCONNECT LEAD E3 FROM AVR AND ISOLATE. CONNECT AVR TERMINAL E3 TO MAIN OUTPUT BLOCK TERM. "W", USING A RED AWG 14 LEAD. (SEE NOTE 1).

AC Wiring Diagram  
 12 & 4 Lead Generators, DST-100-2FAK AVR  
 B-8280E

# Wiring Diagram

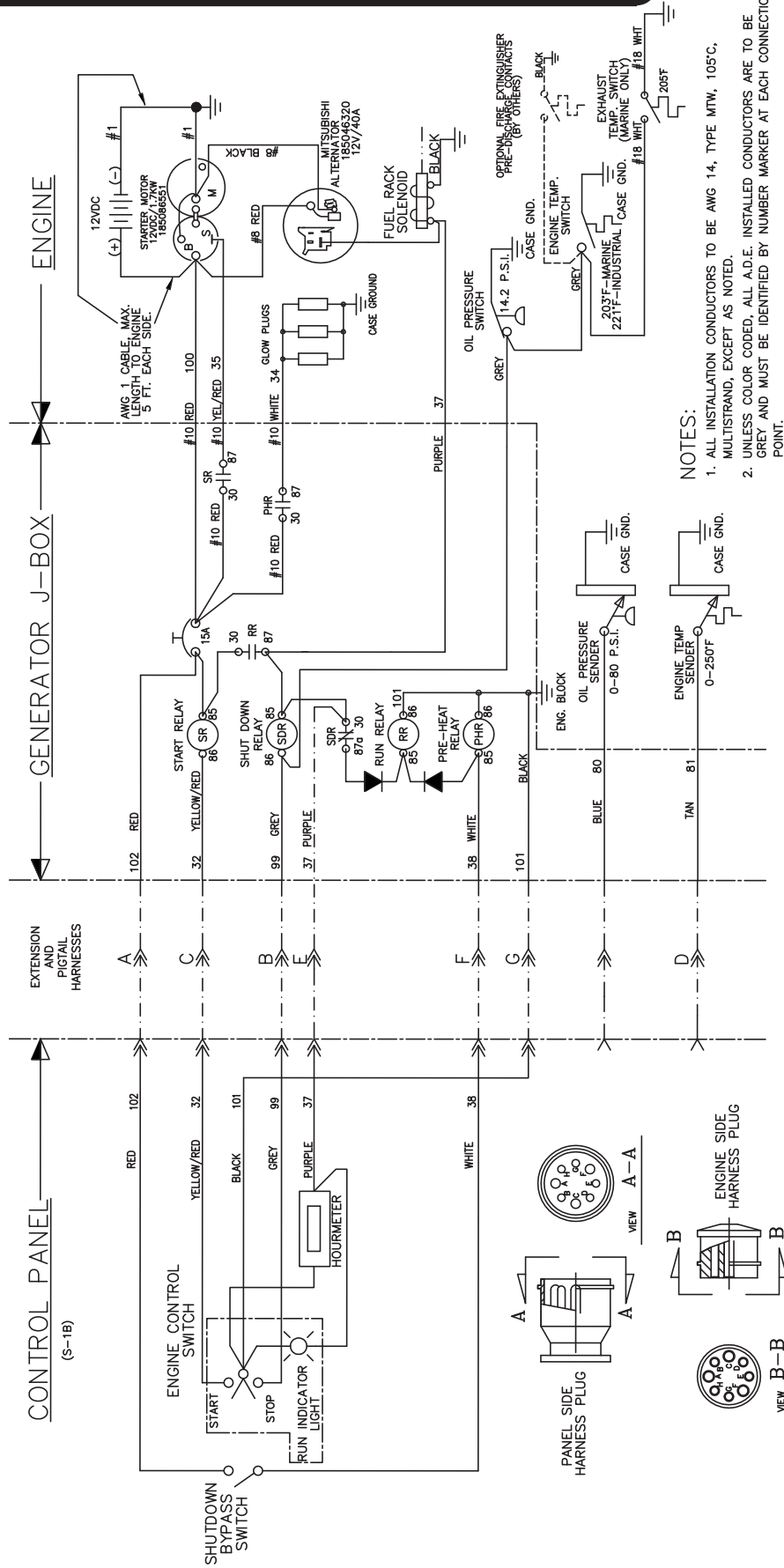

**NOTES:**  
 1. ALL INSTALLATION CONDUCTORS TO BE AWG 14, TYPE MTW, 105°C, MULTISTRAND, EXCEPT AS NOTED.  
 2. UNLESS COLOR CODED, ALL A.D.E. INSTALLED CONDUCTORS ARE TO BE GREY AND MUST BE IDENTIFIED BY NUMBER MARKER AT EACH CONNECTION POINT.

DC Wiring Diagram  
 12 V DC Standard Ground  
 B-8393B







4420 14th Ave. NW., Seattle WA 98107

Tel: (206) 789-3880 • 1-800-762-0165 • Fax: (206) 782-5455

Northern Lights and Lugger are registered trademarks of Northern Lights, Inc.

© 2009 All rights reserved. Litho USA.