

OPERATOR'S MANUAL

OPX300K2

For PX-K2 and C2 series A.C. generator ends





— CALIFORNIA —
Proposition 65 Warning:

Breathing Diesel engine exhaust and some of its constituents are known to the State of California to cause cancer, birth defects, and other reproductive harm.

- * Always start and operate the engine in a well-ventilated area.
- * If in an enclosed area, vent the exhaust to the outside.
- * Do not modify or tamper with the exhaust system.
- * Do not idle the engine except as necessary.

For more information, go to www.P65warnings.ca.gov/diesel.

Northern Lights

4420 14th Avenue NW
Seattle, WA 98107
Tel: (206) 789-3880
Fax: (206) 782-5455

Copyright ©2018 Northern Lights, Inc.
All rights reserved. Northern Lights™, and
the Northern Lights logo are trademarks of
Northern Lights, Inc.

Printed in U.S.A.
PART NO.: OPX300K2 07/18



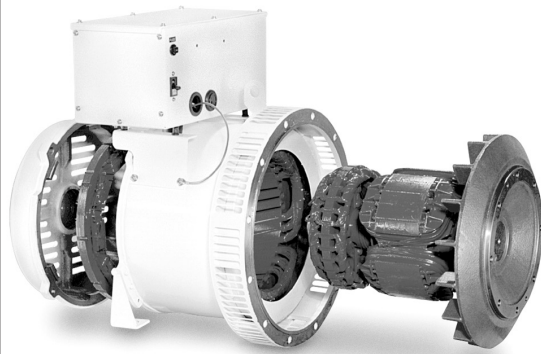

OPERATOR'S & PARTS MANUAL

PX-300K2 SERIES A.C. GENERATORS

For Generator Models:
 PX-308K2, PX-309K2, PX-310K2, PX-312K2, PX-316K2,
 PX-320K2, PX-320C2, PX-325K2, PX-332K2, and PX-332C2

*Read this manual thoroughly before starting your equipment.
 This manual contains information needed to operate your set correctly and safely.*

Table of Contents

Introduction.....	4	OPERATION - GENERATOR SET	
Safety Rules.....	4	Starting.....	9
Models and Serial Numbers	5	Voltage Adjustment.....	9
Mechanical Construction	6	Running.....	9
		Stopping.....	9
INITIAL INSPECTION AND COUPLING		OPERATION - VOLTAGE REGULATOR	
Initial Inspection.....	6	Safety Rules.....	10
Coupling with Prime Mover.....	6	Operation	10
Grounding	6	Adjustment.....	10
PERFORMANCE AND FUNCTION		MAINTENANCE	
Excitation System.....	7	Bearing Inspection	11
Automatic Voltage Regulator (AVR)	7	Insulation Resistance Measurement Method.....	11
Under Speed Protection.....	7	Rotating Rectifier Assembly	11
Rotary Rectifier and Surge Suppressor	7	Parts Replacement Method.....	11 - 12
CHARACTERISTICS		Automatic Voltage Regulator Maintenance.....	13
Voltage Regulation.....	8	SPECIFICATIONS	
Response	8	Generator Specifications.....	14 - 15
Voltage Stability.....	8	Voltage Regulator Specifications.....	16
Motor Starting.....	8	TROUBLESHOOTING	17
Short Circuit.....	8	PARTS LIST	18 - 26
Phase Rotation.....	8	WIRING DIAGRAM	
STANDARD VOLTAGE SELECTION TABLE	8	AVR DST-100-2FAK	27

Proprietary Information

This publication is the property of Northern Lights, Inc.

It may not be reproduced in whole or in part without the written permission of Northern Lights, Inc.

© Northern Lights, Inc. 2014. All rights reserved. Litho U.S.A. Publication number OPX-300K2 04/14

Introduction

This manual describes procedures for operation, maintenance, inspection and adjustment. It will help the operator realize peak performance through effective, economical and safe operation.

- Read this manual carefully BEFORE operating the generator.
- Study this manual until proper operation becomes personal habit.
- Operation, inspection, and maintenance should be carried out carefully. Safety must be given the first priority.

Safety Rules

- To insure years of trouble-free operation, the specified maintenance is important and should be performed.
- **Electrical equipment should always be kept clean.** Oil, dust, moisture and salt are all harmful to generators.
- **Be careful with electricity.** Do not touch rotating parts.
- **Ambient Environmental Conditions**
 - a) **Gas:** Do not use in an environment of corrosive or flammable gas (gasoline, hydrogen sulfide, methane gas, etc.)
 - b) **Sandy Dust:** Do not use equipment in places with excessive sand and dust.
 - c) **Humidity:** Do not use in very humid environments for long periods of time.
 - d) **Salt/Seawater:** Protect your generator from exposure to salt, water, and water vapor.

- **Insulation Resistance and Dielectric:** When measuring insulation resistance and dielectric, be sure to disconnect the AVR and rectifier.
- Be sure that the regulator is shut off by switching the CPR (circuit breaker) on the AVR to the off position when the unit is running at less than rated speed, or when the unit is to be run but no power generation is required.
- Before starting your generator, be sure operating conditions are safe.
- **Ventilation:** When selecting the installation site, be sure that the area is well ventilated and that ambient temperature does not exceed 40°C. If the temperature exceeds 40°C, de-rate the generator output as per “data sheet” for operation.
- Be sure to provide generator with cover and protection when operating outside.

PX-300K2 Series AC generators are based on BS 4999 part 20 and IEC34-5, IP21.

Model and Serial Numbers

GENERATOR END MODEL NUMBERS

Generator Set Model No	PXK Generator Model
M and NL753W2	PX-308K2
M and NL773LW2 / LW3	PX-309K2
M and NL843JW	PX-310K2
M and NL843NW2 / NW3	PX-312K2
M844W2 / W3	PX-316K2
M844LW2 / LW3	PX-320K2
M20CRW2/ CRW3	PX-320C2
M864W / W3	PX-325K2
M944W / W3	PX-332K2
M30CW / CW3	PX-332C2
M984W	PX-332K2
M33CW	PX-332C2

SERIAL NUMBERS

- When referencing Northern Lights equipment by serial number, it is important to differentiate between the engine, generator end, and generator set serial numbers.
- The engine serial number is either on a metal tag or stamped directly into the engine block.
- The generator END serial number is on a metal tag attached to the generator end.
- The generator SET serial number is on a separate metal tag attached to the generator end. It may be a five by one inch tag installed directly below the generator end tag. Or, it may look like the illustrations below. Please use the generator SET number in correspondence or when ordering parts.



NORTHERN LIGHTS

Generator Set Data

Set Serial

Set Model

AC Generator Data

Model No.

Serial No.

DUTY	<input type="text"/>	WIRE	<input type="text"/>
KW	<input type="text"/>	INSUL	<input type="text"/>
KVA	<input type="text"/>	AMB°C	<input type="text"/>
RPM	<input type="text"/>	PF	<input type="text"/>
HERTZ	<input type="text"/>	VOLTS	<input type="text"/>
PHASE	<input type="text"/>	VOLTS	<input type="text"/>
°C RISE	<input type="text"/>	AMPS	<input type="text"/>
RULE	<input type="text"/>	AMPS	<input type="text"/>



Northern Lights, Inc., WA USA
www.northern-lights.com

Figure 1: Generator Set Serial Number Plate

Mechanical Construction

STATOR

The stator frame is fabricated from rolled steel. The round construction provides rigidity and strength to resist excessive mechanical shocks. The stator core is made of high quality silicon steel plates coated with insulating film for prevention of eddy currents. The core is positioned along the internal surface of the frame. The exciter field core is made of special steel plates capable of retaining a high degree of residual magnetism.

BEARINGS

The long-life ball bearings are sealed to prevent grease from escaping and to keep dirt out.

ROTOR

The rotor shaft is made of high quality carbon steel, and is designed and manufactured to be mechanically durable. The rotor is a salient revolving field type with the main field core made from special steel plates having superior magnetic characteristics. The field core elements, exciter rotor, rotary rectifier and cooling fan are integral parts of the same shaft.

VENTILATION

Cooling is provided by the cooling fan of the rotor through suction ports and exhausted through outlet ports. Every machine conforms to the cooling code ICO1 of BS.

Initial Inspection and Coupling

INITIAL INSPECTION

If the generator is stored for long periods of time, store in a clean, dry, ventilated area. After extensive storage time, check the resistance of the coil insulation in accordance with this manual (see **MAINTENANCE**, page 11) before operation. Be sure there are no abnormal sounds or any overheating during operation. It is recommended that standby generators utilize a space heater (optional) in order to keep the coil insulation in optimum working condition.

COUPLING WITH PRIME MOVER

PX-300K series single bearing generators make centering and direct coupling easy. Coupling bolt size and torque will vary according to the engine manufacturer.

GROUNDING

The generator frame should be electrically grounded to the base of the generator set. The neutral is not grounded to the frame unless specified.

Performance and Function

EXCITATION SYSTEM

The excitation system of the PX-300K Series generator uses an Automatic Voltage Regulator (AVR) which uses a portion of the output power to supply controlled DC power to the exciter field (EX) as show in Figure 2. When DC power is supplied to the exciter field, output from the exciter armature is rectified by a 3-phase bridge rotary rectifier (Si) and supplied to the main field coils. See Figure 2.

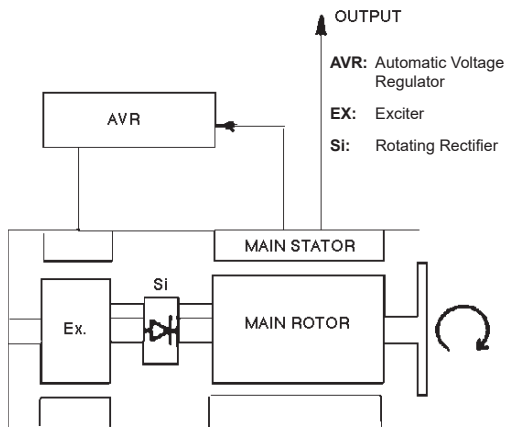

Figure 2: PX-300K2 Block Diagram

AUTOMATIC VOLTAGE REGULATOR (AVR)

The PX-300K2 Series generators use a DST-100-2FAK AVR. This is a compact voltage regulator for generators with an output up to 50kW. The AVR can be used in 120V single phase applications and is installed inside the generator junction box.

The AVR obtains sensing input from the main stator coils and compares the rectified value of the sensing voltage with the reference voltage produced inside the AVR. Input power is obtained from the main stator.

Rectified output power to the exciter field is controlled by switching a transistor on and off. This AVR will control terminal voltage even if the input sine wave is distorted.

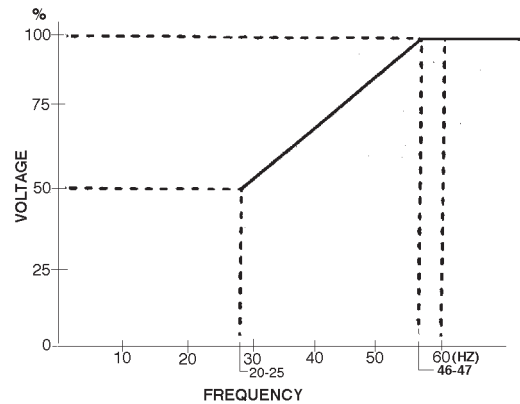

Figure 3: For 50 Hz

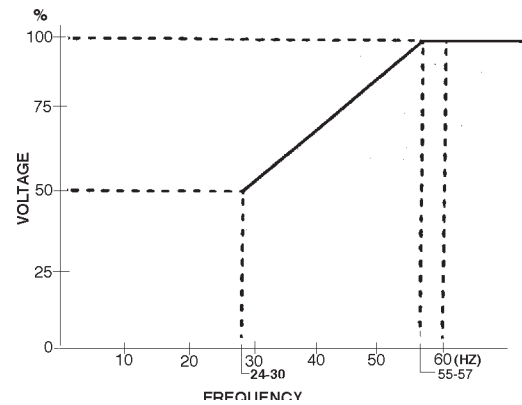

Figure 4: For 60 Hz

UNDER SPEED PROTECTION

A frequency sensing circuit is built into the AVR. When the generator speed drops to 90% of rated speed this circuit protects the AVR by reducing the voltage in proportion to the decrease in engine speed. In addition, when the generator is hit with a rapid overload, this circuit will lower the voltage to protect the engine. See Figures 3 & 4.

ROTARY RECTIFIER AND SURGE SUPPRESSOR

The rotary rectifier assembly, consisting of six diodes, functions as a 3-phase full wave rectifier for the output of the exciter armature and supplies this to the main field. To protect the diodes from large, instantaneous voltage surges, surge absorbers are provided as part of the rotating rectifier assembly.

Characteristics

VOLTAGE REGULATION

Generator terminal voltage regulation is within $\pm 1\%$ of the rated voltage in lagging power factor. 1.0 to 0.8, when the load is varied gradually from no load to full load. This value includes the temperature drift and rotating variation.

RESPONSE

After supplying a load instantaneously, the generator voltage should be restored to the steady condition in accordance with BS4999 Part 40, grade VR2.11 to VR2.23.

VOLTAGE STABILITY

In constant load and engine speed, voltage stability remains 0.25% of the rated voltage.

SHORT CIRCUIT

PX-300K2 Series AC generators can provide over 300% of the rated current for 10 seconds at a powerfactor of 0.

PHASE ROTATION

Phase sequence is T1-T2-T3 (U-V-W, A-B-C) with a counterclockwise rotation of generator viewed from the anti-coupling side.

Standard Voltage Tables and Connection Diagrams

Standard voltage selection table and connection diagram for PX-300K2 Series 1-phase 4-wire and 3-phase 12-wire AC generators.

<i>Winding Connection</i>	<i>Frequency</i>	<i>Voltages</i>			
3 Phase Series Star (High Wye)	60 Hz	480/277	460/266	440/254	416/240
	50 Hz	415/240	400/231	380/219	
3 Phase Parallel Star (Low Wye)	60 Hz	240/139	230/133	220/127	208/120
	50 Hz	208/120	200/115	190/110	
1 Phase	60 Hz	120/240			
	60 Hz	120			
1 Phase	50 Hz	100/200	110/220	115/230	120/240
	50 Hz	110			

Figure 5: Standard Voltage Table

Operation – Generator Set

STARTING

Before starting generator, check the following:

1. Make sure that the wiring is correct.
2. Be sure that nothing is blocking the air inlet/ outlet.
3. Make sure that the inside of the generator is clean.
4. Be sure the main line circuit breaker is switched OFF.

After checking each of the above, start the generator in the following procedure:

1. Start engine in accordance with instructions in the Operator's Manual. Be sure there is no abnormal sound or vibration.
2. The voltage will rise due to the increase in generator speed. After making sure that each interphase voltage is balanced, set the voltage and frequency to the rated level. Be sure the CPR switch is "ON". The voltage will not rise with CPR "OFF".
3. After running the generator without load, switch the circuit breaker ON to start the load operation.

VOLTAGE ADJUSTMENT

The generator has been adjusted to obtain optimum voltage at the factory. If the voltage is different, adjust the voltage with the Voltage Adjust provided on the AVR.

RUNNING

Check the following while operating the generator:

1. Abnormal vibration and/or sound
2. Load
3. Environment:

Keep the air inlet/outlet clean and clear for optimum cooling. Insufficient cooling causes overheating of the generator.

Note: *When a 3-phase generator is used at single phase load, each phase current should be balanced and should not exceed 50% of the rated current. In addition, allowable unbalanced load is listed on the Data Sheet.*

STOPPING

After putting the running generator in a no-load condition by removing the generator load, stop the engine in accordance with the Engine Manual.

Operation – Automatic Voltage Regulator

SAFETY RULES

- Do not leave AVR connected when testing generator with high-pot or megger.
- Adjust the engine only when the CPR is in “OFF” position.

OPERATION

1. Make sure the wiring is correct.
2. Make sure the frequency selection switch is set to the rated frequency (60 or 50 Hz).
3. To adjust the voltage turn the Voltage Adjust (VR1) counter-clock wise. Make sure the CPR is “ON”.
 - a. Start the engine with no load and increase the engine speed slowly to the rated level.
The voltage will automatically build up (residual voltage: more than 10V).
 - b. Adjust to the rated voltage using the Voltage Adjust (VR1).
 - c. Make sure of the proper Volt/Frequency characteristic by reducing the generator speed.
 - d. Make sure of voltage stability by switching the load “ON” or “OFF”. Use the Stability Adjust (VR2).
 - e. If you find no problem with the AVR, start the normal operation.

ADJUSTMENT

Each component of the AVR is adjusted at the factory to obtain optimum voltage. If readjustment is necessary, make sure the voltage, frequency, load, etc. are functioning properly after readjustment.

1. **Initial Excitation:** *For initial excitation use a DC12V or DC24V battery.*

- a. Stop the generator.
- b. Remove the AVR connectors.
- c. Connect the field terminal F(+) with the polarity (+) of battery and the terminal F (-) with the polarity (-) and excite AVR field for 2 or 3 seconds.

2. Voltage Adjustment:

If the voltage output is low, increase the voltage by turning the Voltage Adjust (VR1) slowly clockwise.

3. Stability:

If the voltage output is unstable, increase the voltage by turning the Stability Adjust (VR2) clockwise.

4. Voltage and Frequency:

Voltage and Frequency (Hz) have been preset at the factory.

Maintenance

BEARING INSPECTION

For bearing inspection, make sure that there is no abnormal sound during normal running and no over-heating. Greasing is not necessary for generators using the double seal type ball bearings, but these will need to be replaced after every 10,000 hours of operation (see **PARTS REPLACEMENT METHOD**).

INSULATION RESISTANCE MEASUREMENT

If the generator has not been used for a long time, check the insulation resistance of each lead wire at 500V with a megger.

It is usually enough to check only the stator winding. In order to prevent damage to the AVR, disconnect it. If the measured insulation resistance value is above 2 M ohms, there is no problem, but if it is lower than that, check to see if the inside of the generator is wet or dirty. If dust has accumulated, blow it out with dry compressed air. Wipe off oil stains with a cloth. If the generator is damp, dry it and re-check.

ROTATING RECTIFIER ASSEMBLY

The rotating rectifier assembly needs little attention. Clean off dust and oil stains periodically. In the unlikely event that it becomes necessary to replace the diode elements and surge absorber elements. Refer to **PARTS REPLACEMENT METHOD**.

PARTS REPLACEMENT METHOD

1. Bearing Replacement:
 - a. In order to replace the bearing, first remove the bearing holder housing on the end of the generator. Loosen and remove the four housing bolts. Remove the bearing holder gently since there is a risk that the rotor could fall and damage the exciter rotor or the exciter stator.

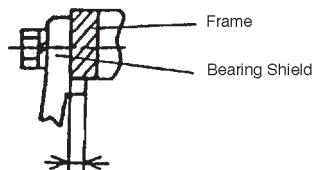

Figure 6. Pilot Length

- b. Using a bearing puller, extract bearing from shaft.
- c. When installing a new bearing, place a steel pipe on the inner race surface, and fit the bearing by tapping it lightly with a hammer.

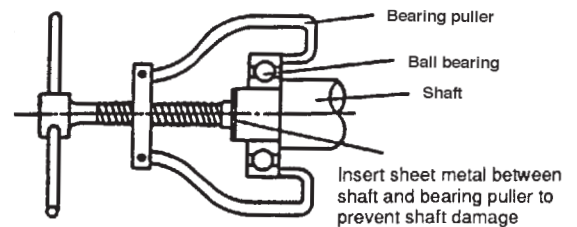

Figure 7. Bearing Puller

Note: Absolutely do not apply pressure to outer race of the bearing during insertion.

Maintenance

2. Replacement of Rotary Rectifier Parts:

- a. Rotary rectifier parts are all located at the rear of Exciter rotor. For parts replacement, remove the bearing shield.
- b. To test the rotating rectifier diodes, disconnect the lead to the diode element and measure the resistance between the anode and cathode on each diode (see Figure 8).

Caution: Do not overheat the diodes. If the resistance value of the diode in the forward direction is low and the reverse direction resistance value shows infinity, it is good. If this is not the case, the diode element is defective and must be replaced. The diode elements can be damaged if overtightened.

- c. "J" type diode elements are fastened to the J(+) side of the rotating rectifier assembly, and "K" type diode elements to the K(-) side.

- Good surge absorber elements have about 10-30 K ohms, but if the resistance reading is near 0 ohms, the surge absorber elements is defective and must be replaced.
- Also, inspect outside of surge absorber and replace if it is cracked.
- In addition, when installing surge absorber elements, apply Loctite to the bolts.

3. Bearing Housing Replacement:

Inspect the O-Ring. If cracked, replace. Reassemble carefully, aligning housing with bearing. Tighten housing bolts to 2.5 kpm (18 ft/lbs.).

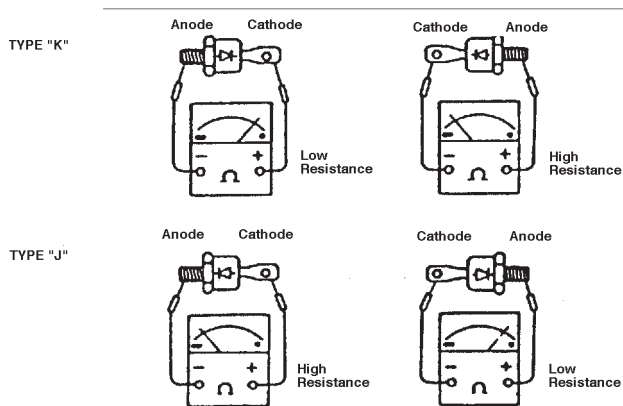

Figure 8. Testing Diode Elements

- d. The Diode Torque Specifications for all 300 series models is **5 mm = 48 in. lb.**
- e. In order to test whether the rotating rectifier assembly surge absorber elements are good or not, first disconnect all lead wires as described in **PARTS REPLACEMENT METHOD**, Point 2, (above) and measure the resistance across surge absorber elements with a tester.

4. Rotating Rectifier Assembly Detailed Structure:

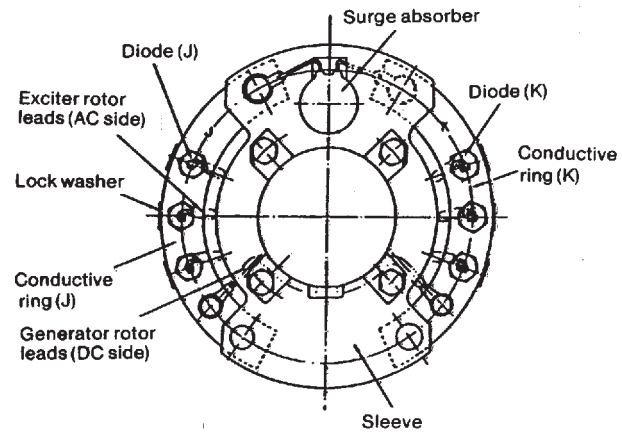

Figure 9. Rotating Rectifier.

Maintenance – Automatic Voltage Regulator

1. Keep the AVR clean at all times. Make sure no dust or moisture accumulates on the AVR.
2. Inspect periodically making sure that wiring connections are not loose.

Generator Specifications: Taiyo Winding Resistances

All ratings in Ohms @ 20° C

	Model Number	1 Phase	3 Phase
MAIN STATOR:	PX-308K2	0.588 ohms	0.656 ohms
	PX-309K2	0.588 ohms	0.656 ohms
	PX-310K2	0.527 ohms	0.436 ohms
	PX-312K2	0.298 ohms	0.315 ohms
	PX-316K2	0.234 ohms	0.198 ohms
	PX-320K2 & PX-320C2	0.195 ohms	0.136 ohms
	PX-325K2	0.115 ohms	0.0950 ohms
	PX-332K2 & PX-332C2	0.094 ohms	0.0817 ohms
	Model Number	1 Phase	3 Phase
MAIN ROTOR:	PX-308K2	1.84 ohms	1.84 ohms
	PX-309K2	1.84 ohms	1.84 ohms
	PX-310K2	1.95 ohms	1.95 ohms
	PX-312K2	2.10 ohms	2.10 ohms
	PX-316K2	2.40 ohms	2.40 ohms
	PX-320K2 & PX-320C2	2.77 ohms	2.77 ohms
	PX-325K2	3.60 ohms	3.60 ohms
	PX-332K2 & PX-332C2	3.91 ohms	3.91 ohms
	Model Number	1 Phase	3 Phase
EXCITER STATOR:	PX-308K2 & PX-309K2	15.8 ohms	15.8 ohms
	PX-310K2	15.8 ohms	15.8 ohms
	PX-312K2	15.8 ohms	15.8 ohms
	PX-316K2	17.0 ohms	17.0 ohms
	PX-320K2 & PX-320C2	17.0 ohms	17.0 ohms
	PX-325K2	17.0 ohms	17.0 ohms
	PX-332K2 & PX-332C2	19.2 ohms	19.2 ohms

Generator Specifications: Taiyo Winding Resistances

All ratings in Ohms @ 20° C

	Model Number	1 Phase	3 Phase
EXCITER ROTOR:	PX-308K2 & PX-309K2	0.510 ohms	0.510 ohms
	PX-310K2	0.510 ohms	0.510 ohms
	PX-312K2	0.510 ohms	0.510 ohms
	PX-316K2	0.530 ohms	0.530 ohms
	PX-320K2 & PX-320C2	0.530 ohms	0.530 ohms
	PX-325K2	0.530 ohms	0.530 ohms
	PX-332K2 & PX-332C2	0.580 ohms	0.580 ohms
	Model Number	1 Phase	3 Phase
FULL LOAD EXCITATION VOLTAGE:	PX-308K2 & PX-309K2		
	50 Hz/ 220 volts	31.8 volts	23.0 volts
	60 Hz/ 240 volts	37.5 volts	27.1 volts
	PX-310K2		
	50 Hz/ 220 volts	36.4 volts	26.2 volts
	60 Hz/ 240 volts	41.7 volts	28.9 volts
	PX-312K2		
	50 Hz/ 220 volts	45.5 volts	32.8 volts
	60 Hz/ 240 volts	50.0 volts	36.1 volts
	PX-316K2		
	50 Hz/ 220 volts	54.5 volts	39.4 volts
	60 Hz/ 240 volts	66.7 volts	48.1 volts
	PX-320K2 & PX-320C2		
	50 Hz/ 220 volts	72.7 volts	52.5 volts
	60 Hz/ 240 volts	83.3 volts	60.1 volts
	PX-325K2		
	50 Hz/ 220 volts	90.9 volts	52.5 volts
	60 Hz/ 240 volts	104.2 volts	60.1 volts
PX-332K2 & PX-332C2			
50 Hz/ 220 volts	118.2 volts	68.2 volts	
60 Hz/ 240 volts	137.5 volts	79.4 volts	
AUXILIARY WINDING:	PX-309K2	5.87 V	2.89 V
	PX-310K2	6.31 V	2.45 V
	PX-312K2	5.31 V	2.37 V
	PX-316K2	4.41 V	1.58 V
	PX-320K2 & PX-320C2	3.49 V	1.57 V
	PX-325K2	3.29 V	1.67 V
	PX-332K2 & PX-332C2	3.09 V	1.49 V

Automatic Voltage Regulator: DST-100-2FAK

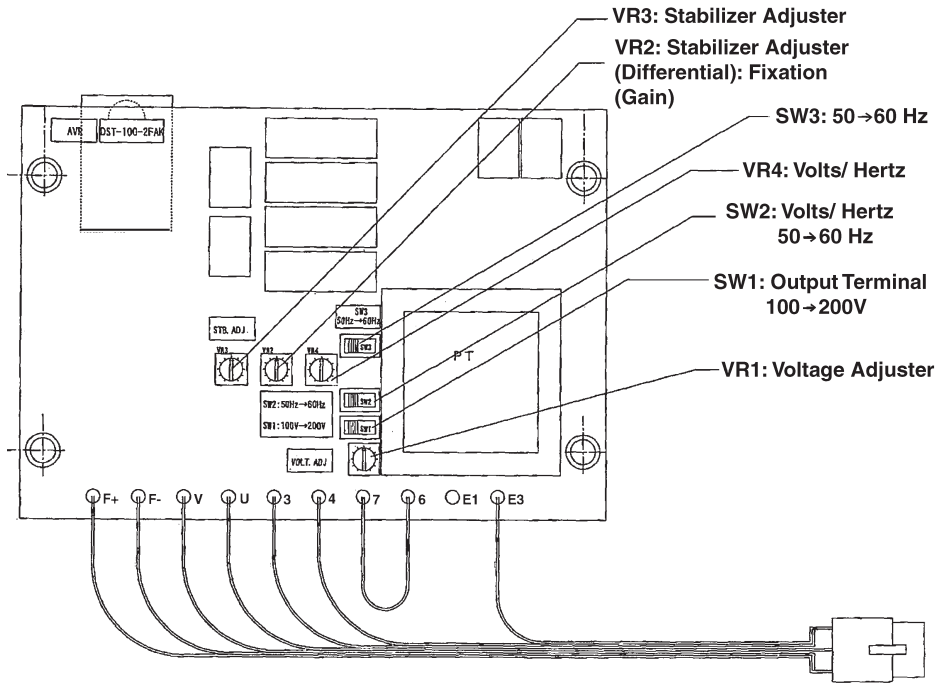

Sensing Output	Frequency	50 Hz	60 Hz
Voltage	100 Volt Class	100V (86.5V~110V~120V)	120V
	200 Volt Class	200V (173V~220V~240V)	240V
	Phase:	Single Phase	Single Phase
Power Input	Voltage:	100V ~ 127V ~	139V
	Frequency:	50 Hz /	60 Hz
	Phase:	Single Phase	Single Phase
Sensing Output (F+) – (F-)	Max. Voltage:	87% of Power Input Voltage (DC Voltage)	
	Continuous Current:	Maximum 3A Current	
	Current Maximum Forcing:	9A forcing 1 to 5 seconds at 25°C	
	Field Resistance:	Minimum 15 Ohms	
Voltage Adjust Range	Minimum ±5% of Normal Voltage		
Volt/ Hertz Characteristic	57 Hz in 60 Hz operation mode, 47 Hz in 50 Hz operation mode		
Voltage Build-Up	Self-Building Up at over 6V Power Input Voltage		
Voltage Changeable Rate	Maximum ±1.5%		
Temperature Drift	Within ±0.02%/ degree C		
Operating Temperature	-4°F (-20°C) to 140°F (60°C)		
Storage Temperature	-4°F (-20°C) to 158°F (70°C)		
Outside Dimension	5.6" x 4.0" x 1.57" (140mm x 100mm x 40 mm)		
Weight	1.4 lbs. (0.65 kgs)		

Trouble Shooting

PROBLEM	POSSIBLE CAUSE	RECOMMENDATION(S)
Only a FEW VOLTS of output	Loss of residual magnetism of the exciter field Disconnection or short circuit of windings Defective AVR Defective rotating rectifier assembly	<ul style="list-style-type: none"> • Flash field. • Check the insulation of all windings and check the resistance value. • Check the AVR. • Replace diode elements.
Voltage is LOW	Incorrect wiring (GEN, AVR) Low speed Overload Defective AVR	<ul style="list-style-type: none"> • Check the winding connection. • Check the engine. • Reduce the load. • Check the AVR.
Voltage DIPS when on load Voltage is HIGH	Starting of big motor or spot welding machine Defective diode on rotating rectifier [F(+) – F(-) terminal voltage will show a very high value when a diode is defective] Incorrect wiring (GEN, AVR) Too high speed Defective AVR	<ul style="list-style-type: none"> • About 15% voltage dip is no problem. • Change diode. • Check the AVR. • Check the engine. • Check the AVR.
Voltage FLUCTUATES	Wiring leads are loose Irregular speed of engine Poor AVR adjustment External noise	<ul style="list-style-type: none"> • Tighten leads. • Check the engine. • Check the AVR. • Check the filter.
Abnormal SOUND or VIBRATION	Foundation uneven Poor mounting Misaligned coupling Defective bearing	<ul style="list-style-type: none"> • Check ground level. • Check the mounting section. • Check the coupling section. • Replace the bearing.

PX-300K2 Series Parts List

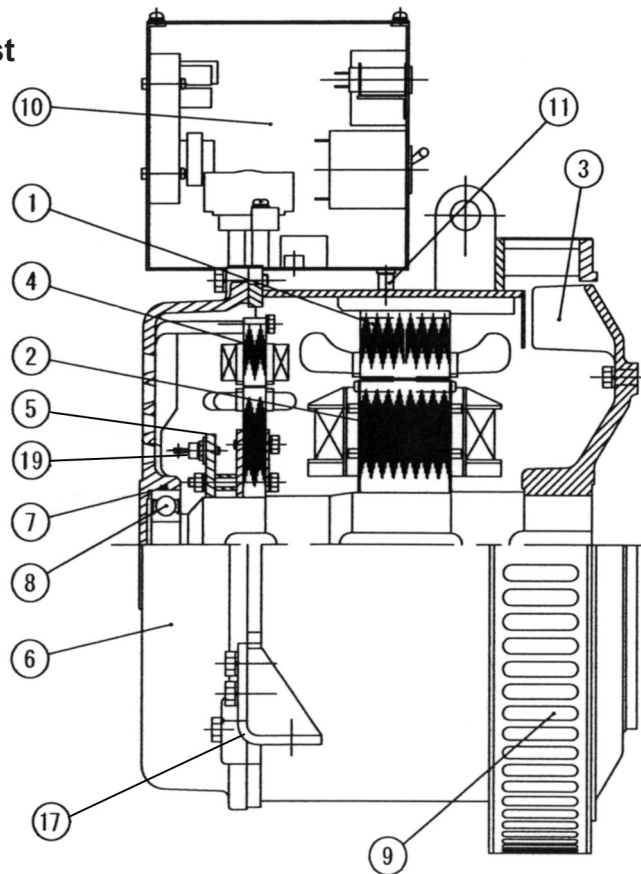

PX308 to PX316K2 generators

3T102-344

No	Description	PX-308K2	PX-309K2	PX-310K2	PX-312K2	PX-316K2
1	Stator Assembly (1-Phase)	WKC-00112-ST	WKC-00112-ST	WKC-00094-ST	WKC-00095-ST	WKC-00096-ST
	Stator Assembly (3-Phase)	WKC-00113-ST	WKC-00113-ST	WKC-00101-ST	WKC-00102-ST	WKC-00103-ST
2	Rotor Assembly	WKC-00112-RT	WKC-00112-RT	WKC-00094-RT	WKC-00095-RT	WKC-00096-RT
3	Rotor Fan	3T301-254-4	3T301-593-2	3T301-255-4	3T301-255-4	3T301-255-4
4	Excitor Stator Assembly (1-Phase)	WKC-00107-ST	WKC-00107-ST	WKC-00107-ST	WKC-00107-ST	WKC-00108-ST
5	Rectifier Assembly	3T201-084-3*	3T201-084-3*	3T201-084-3*	3T201-084-3*	3T201-084-3*
6	Bearing Shield	3T301-253-4	3T301-253-4	3T301-253-4	3T301-253-4	3T301-253-4
7	O-Ring	1AG72	1AG72	1AG72	1AG72	1AG72
8	Ball Bearing	6306ZZ	6306ZZ	6306ZZ	6306ZZ	6306ZZ
9	Ventilation Cover (M Type)	3T301-329	3T301-329	3T301-331	3T301-331	3T301-331
	Ventilation Cover (NL Type)	3T301-330	3T301-330	3T301-332	3T301-332	3T301-332
10	Junction Box (M Type) 1 Phase	3T102-346	3T102-346	3T102-346	3T102-346	3T102-346
	Junction Box (NL Type) 1 Phase	3T102-349	3T102-349	3T102-349	3T102-349	3T102-349
	Junction Box (M Type) 3 Phase	3T102-350	3T102-350	3T102-350	3T102-350	3T102-350
	Junction Box (NL Type) 3 Phase	3T102-352	3T102-352	3T102-352	3T102-352	3T102-352
11	Rubber Mount	33-40007	33-40007	33-40007	33-40007	33-40007
13	Automatic Voltage Regulator	22-42071	22-42071	22-42071	22-42071	22-42071
14	Circuit Breaker (Voltage Regulator)	22-42084**	22-42084**	22-42084**	22-42084**	22-42084**
15	Circuit Breaker (Engine)	22-42043	22-42043	22-42043	22-42043	22-42043
17	Generator Mounting Bracket (R)	3T303-278 R	3T303-278 R	3T303-372 R	3T303-372 R	3T302-857-1 R
	Generator Mounting Bracket (L)	3T303-278 L	3T303-278 L	3T303-372 L	3T303-372 L	3T301-857-1 L
18	Surge Suppressor for 3T201-084	ENC471D-2DA	ENC471D-2DA	ENC471D-2DA	ENC471D-2DA	ENC471D-2DA
19	Diode Element	SKN26/12***	SKN26/12***	SKN26/12***	SKN26/12***	SKN26/12***
	Diode Element	SKR26/12****	SKR26/12****	SKR26/12****	SKR26/12****	SKR26/12****
		*replaces 3T201-084-2	**replaces 22-42077	***replaces SIDO1-09 (74113)	****replaces ERD51-09 (74114)	

PX-300K2 Series Parts List

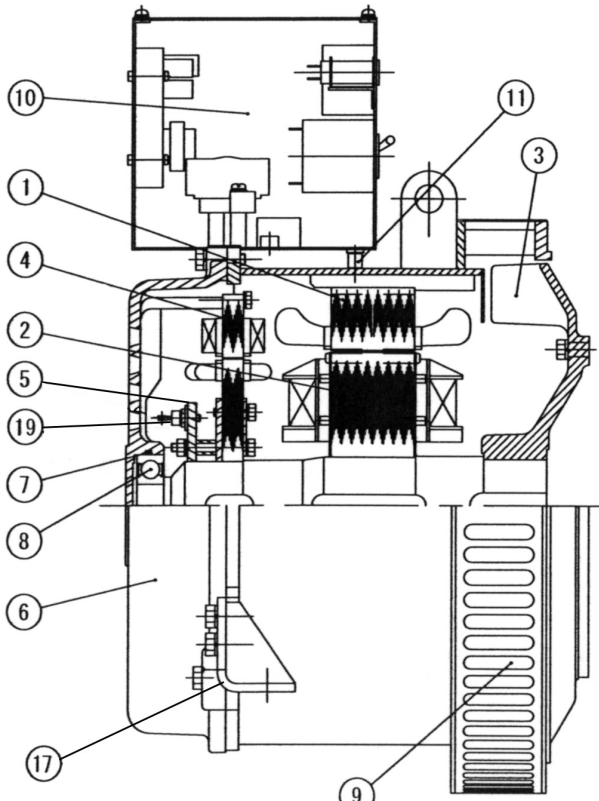

PX320 to PX325K2 generators

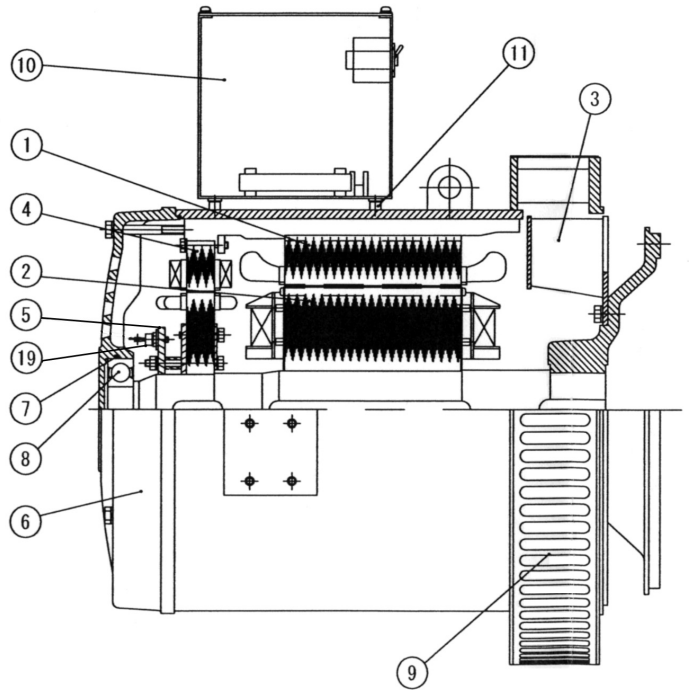

PX332K2 generators

3T102-344

No	Description	PX-320K2	PX-325K2	PX-332K2	
1	Stator Assembly (1-Phase)	WKC-00097-ST	WKC-00098-ST	WKC-00099-ST	
	Stator Assembly (3-Phase)	WKC-00104-ST	WKC-00105-ST	WKC-00106-ST	
2	Rotor Assembly	WKC-00097-RT	WKC-00098-RT	WKC-00099-RT	
3	Rotor Fan	3T301-255-4	3T301-255-4	3T301-553	
4	Excitor Stator Assembly (1-Phase)	WKC-00108-ST	WKC-00108-ST	WKC-00109-ST	
5	Rectifier Assembly	3T201-084-3*	3T201-084-3*	3T201-084-3*	*replaces 3T201-084
6	Bearing Shield	3T301-253-4	3T301-253-4	3T301-349-2	
7	O-Ring	1AG72	1AG72	1BG90	
8	Ball Bearing	6306ZZ	6306ZZ	6308ZZ	
9	Ventilation Cover (M Type)	3T301-331	3T301-331	3T301-389	
	Ventilation Cover (NL Type)	3T301-332	_____	3T301-389	
10	Junction Box (M Type) 1 Phase	3T102-346	3T102-347	3T102-348	
	Junction Box (NL Type) 1 Phase	3T102-349	_____	3T102-348	
	Junction Box (M Type) 3 Phase	3T102-350	3T102-350	3T102-351	
	Junction Box (NL Type) 3 Phase	3T102-352	_____	3T102-351	
11	Rubber Mount	33-40007	33-40007	33-40007	
13	Automatic Voltage Regulator	22-42071	22-42071	22-42071	
14	Circuit Breaker (Voltage Regulator)	22-42084**	22-42084**	22-42084**	**replaces 22-42077
15	Circuit Breaker (Engine)	22-42043	22-42043	22-42043	
17	Generator Mounting Bracket (R)	3T302-857-1 R	3T302-857-1 R	23-65413	
	Generator Mounting Bracket (L)	3T302-857-1 L	3T302-857-1 L	23-65413	} M984 & M33C M944 & M30CW
	Generator Mtg. Bracket (R&L)			23-61201	
18	Surge Suppressor for 3T201-084	ENC471D-2DA	ENC471D-2DA	ENC471D-2DA	
19	Diode Element	SKN26/12***	SKN26/12***	SKN26/12***	***replaces SID01-09 (74113)
	Diode Element	SKR26/12****	SKR26/12****	SKR26/12****	****replaces ERD51-09 (74114)

PX-320C2 Parts List

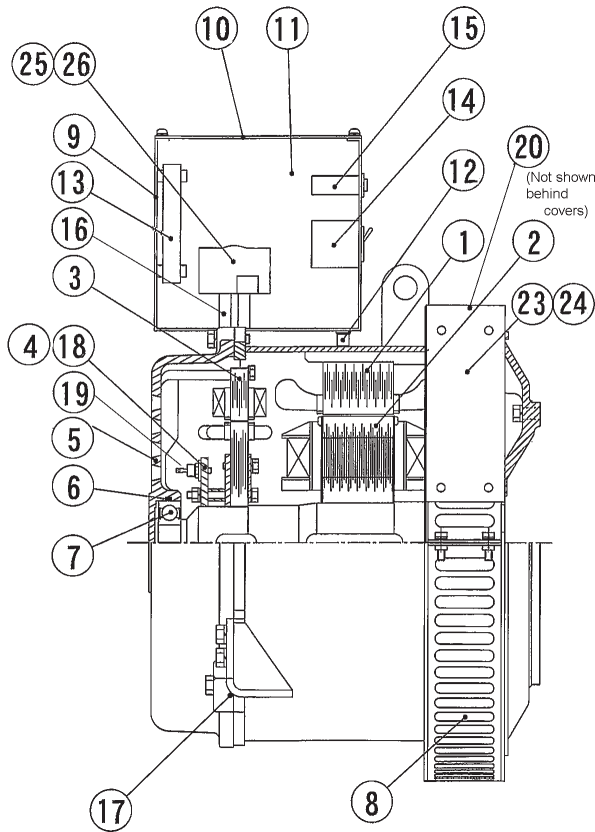

PX320C2 generator

PX320C

No	Description	PX-320C2		
1	Stator Assembly		WKC-00104-5-ST	
2	Rotor Assembly		WKC-00104-5-RT	
3	Excitor Stator Assembly		WKC-00108-ST	
4	Rectifier Assembly		3T201-084-3*	*replaces 3T201-084
5	Bearing Shield		3T301-253-4	
6	O-Ring		1AG72	
7	Ball Bearing		6306ZZ	
8	Ventilation Cover (M Type)		3T302-896	
9	Junction Box (M Type)		3T303-290-2	
10	Junction Box Top		4T301-108	
11	Junction Box Side (2 ea.)		4T301-109	
12	Rubber Mount		33-40007	
13	Automatic Voltage Regulator		22-42071	
14	Circuit Breaker (Voltage Regulator)		22-42084**	**replaces 22-42077
15	Circuit Breaker (Engine)		22-42043	
16	Spacer		4T301-181	(4 ea.)
17	Generator Mounting Bracket (R)		3T302-857-1 R	
	Generator Mounting Bracket (L)		3T302-857-1 L	
18	Surge Suppressor for 3T201-084		ENC471D-2DA	
19	Diode Element		SKN26/12***	(3 ea.) ***replaces SID01-09 (74113)
	Diode Element		SKR26/12****	(3 ea.) ****replaces ERD51-09 (74114)
20	Rotor Fan & Coupling		3T301-255-4	
23	Drip Proof Cover		4T302-897	
24	Foot for Drip Proof Cover (4 ea.)		4T302-898	
25	Terminal Strip (Auxiliary)		TE-K22-4	
26	Terminal Strip (Output)		UK60-3J	

PX-332C2 Parts List

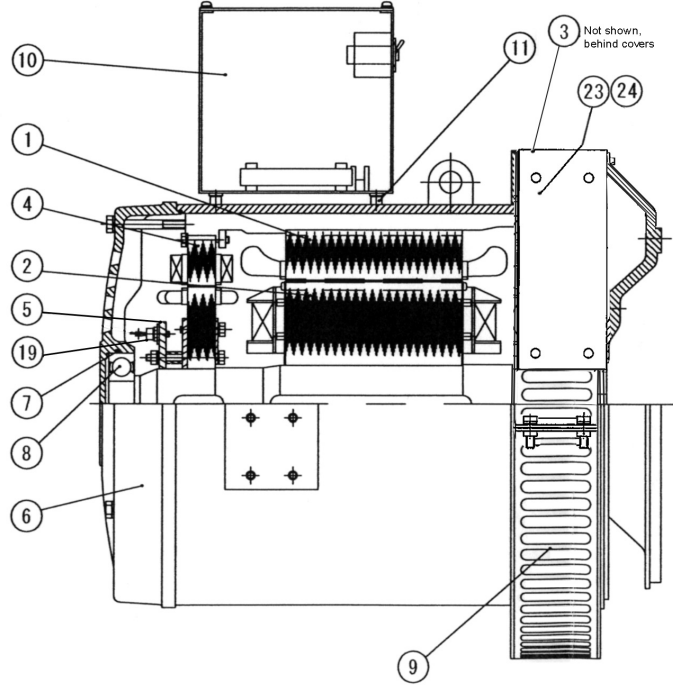

PX332C2 generator

3T102-344

No Description		PX-332C2		
1	Stator Assembly (1-Phase)		WKC-00099-ST	
	Stator Assembly (3-Phase)		WKC-00106-ST	
2	Rotor Assembly		WKC-00099-RT	
3	Rotor Fan		3T301-553	
4	Excitor Stator Assembly (1-Phase)		WKC-00109-ST	
5	Rectifier Assembly		3T201-084-3*	*replaces 3T201-084
6	Bearing Shield		3T301-349-2	
7	O-Ring		1BG90	
8	Ball Bearing		6308ZZ	
9	Ventilation Cover (M Type)		3T302-796-1	
10	Junction Box (M Type) 1 Phase		3T102-348	
	Junction Box (M Type) 3 Phase		3T102-351	
11	Rubber Mount		33-40007	
13	Automatic Voltage Regulator		22-42071	
14	Circuit Breaker (Voltage Regulator)		22-42084**	**replaces 22-42077
15	Circuit Breaker (Engine)		22-42043	
17	Generator Mounting Bracket (R)		23-65413	M33CW
	Generator Mounting Bracket (L)		23-65413	M33CW
	Generator Mtg. Bracket (R&L)		23-61201	M30CW
18	Surge Suppressor for 3T201-084		ENC471D-2DA	
19	Diode Element		SKN26/12***	***replaces SID01-09 (74113)
	Diode Element		SKR26/12****	****replaces ERD51-09 (74114)
23	Drip Proof Cover		4T302-797	
24	Foot for Drip Proof Cover		4T302-798	

**PX-308K2 to PX-320K2
Junction Box, Single Phase, Marine**

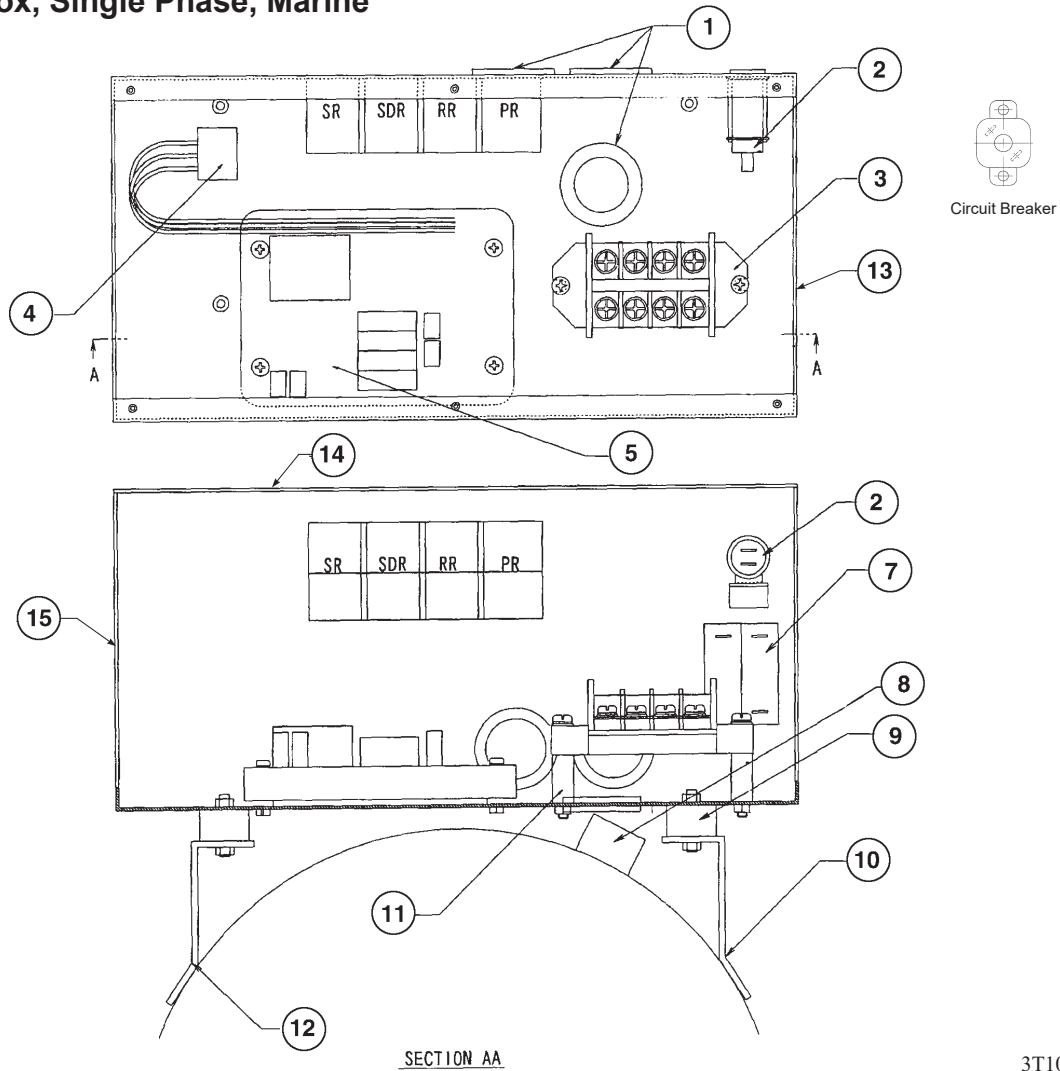

SECTION AA

3T102-346

Key	Description	Part Number	
1	Grommet	NG-79-R	
2	DC Circuit Breaker	22-42043	* Snap-in - use with #13
	Circuit Breaker 15A	22-40674	* 2 Screw Mtg - use with
3	Terminal	22-42036	
4	Plug	3191-09P	
5	Automatic Voltage Regulator (DST-100-2FAK)	22-42071	
7	AC Circuit Breaker 2 Amp x 3 Amp 2 Pole	22-42084*	*replaces 22-42077
8	Rubber Tube		
9	Rubber Mount	33-40007 (4 ea.)	
10	Bracket, Junction Box Mtg. - Right	4T301-309	
11	Spacer	4T301-181 (2 ea.)	
12	Bracket, Junction Box Mtg. - Left	4T301-310	
13	Junction Box	3T303-289-2* (2 ea.)	*replaces 3T303-289-1
14	Top Panel	4T301-108	
15	Side Panel	4T301-109 (2 ea.)	

**PX-325K2
Junction Box, Single Phase, Marine**

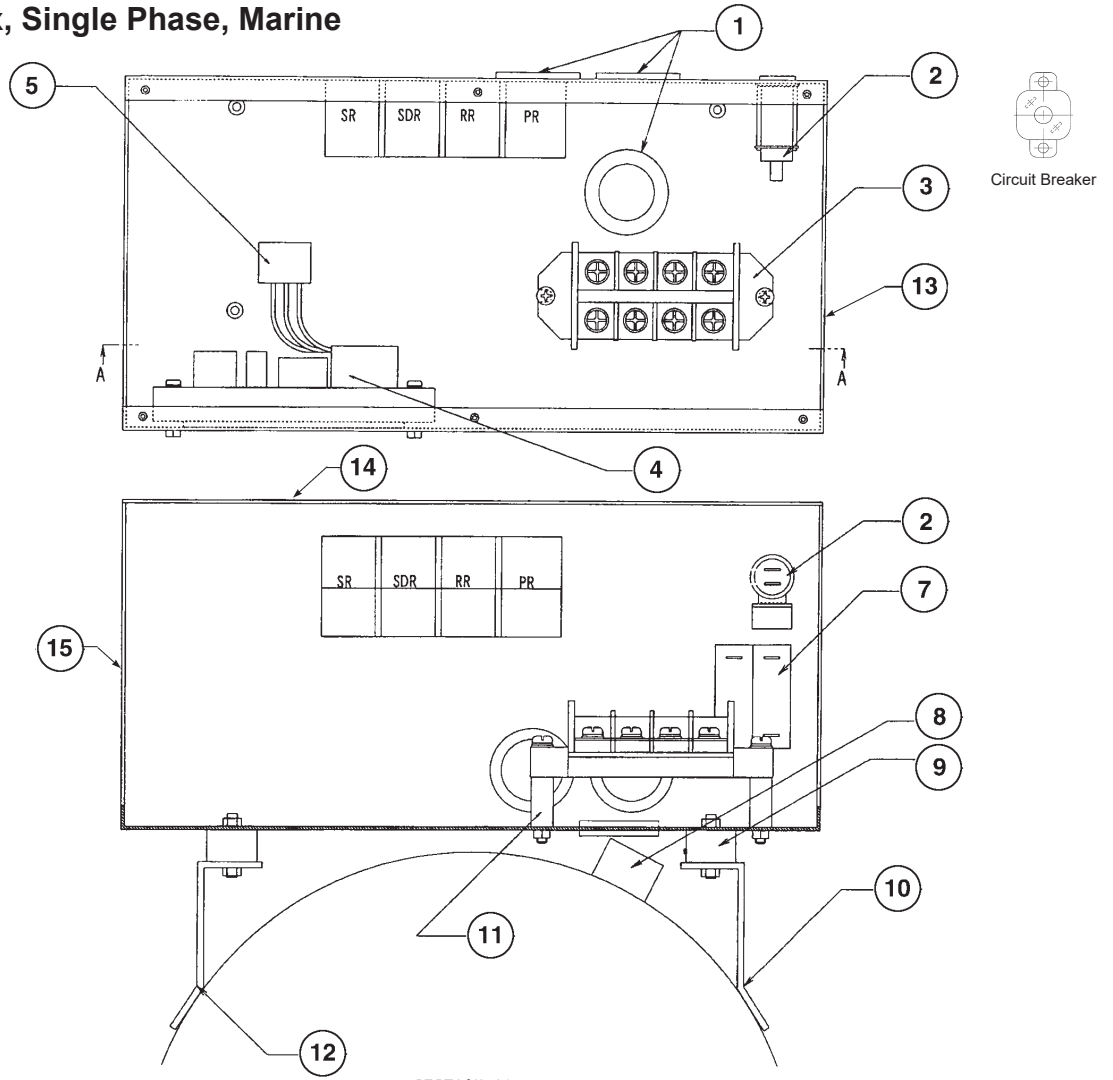

SECTION AA

3T102-347

Key	Description	Part Number	
1	Grommet	NG-79-R	
2	DC Circuit Breaker 15 Amp	22-42043	
3	Terminal	UKT100-4J	
4	Automatic Voltage Regulator (DST-100-2FAK)	22-42071	
5	Plug	3191-09P	
7	AC Circuit Breaker 2 Amp x 3 Amp 2 Pole	22-42084*	*replaces 22-42077
8	Rubber Tube		
9	Rubber Mount	33-40007 (4 ea.)	
10	Bracket, Junction Box - Right	4T301-309	
11	Spacer	4T301-181 (2 ea.)	
12	Bracket, Junction Box Mtg. - Left	4T301-310	
13	Junction Box	3T303-292-2**	**formerly #3T303-292-1
14	Top Panel	4T301-108	
15	Side Panel	4T301-109 (2 ea.)	

PX-332K2
Junction Box, Single Phase, Marine

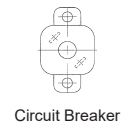
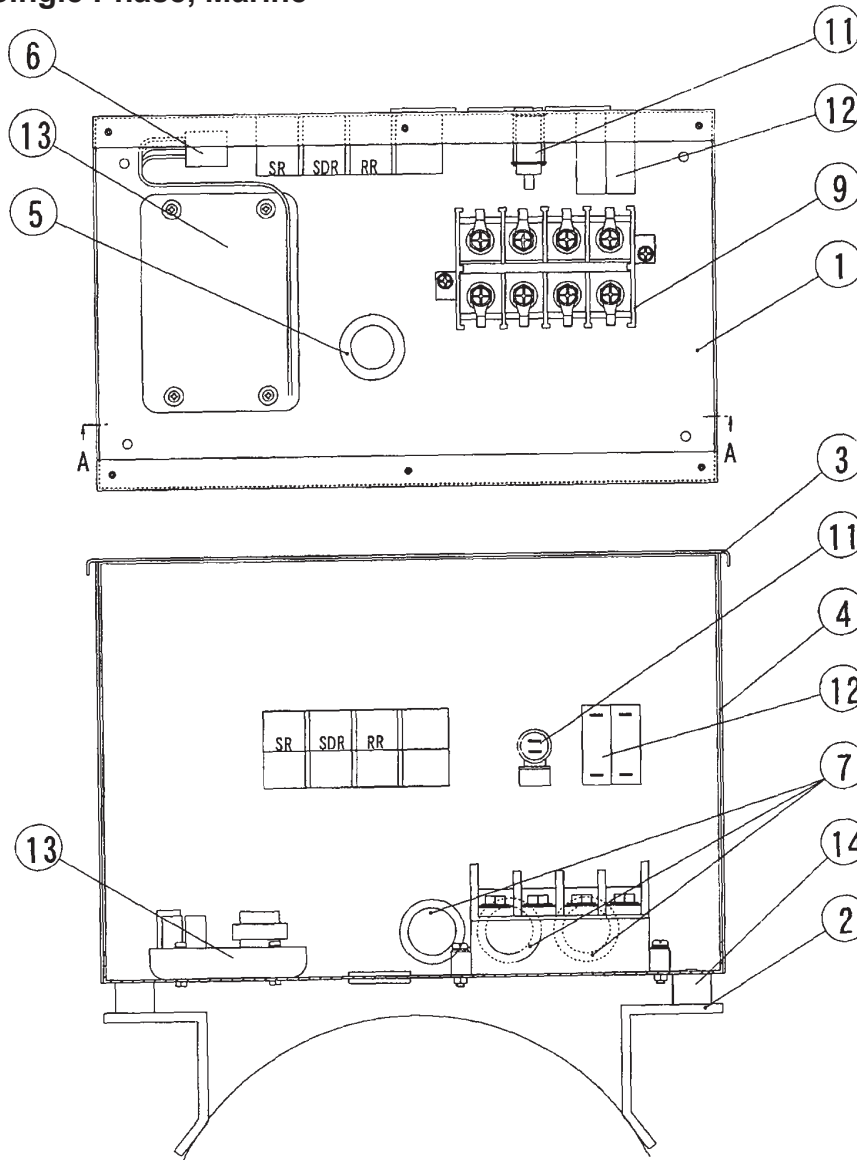

3T102-348

Key	Description	Part Number	
1	Junction Box	3T303-291-3*	*replaces 3T303-291-1
2	Bracket, Junction Box Mounting	3T302-782-1 (2 ea.)	
3	Top Panel	4T302-144	
4	Side Panel	4T302-859 (2 ea.)	
5	Grommet	4M911-018	
6	Plug	3191-09P	
7	Grommet	NG-79-R	
9	Terminal Strip	22-45413	
11	DC Circuit Breaker 15 Amp	22-42043	
12	AC Circuit Breaker 2 Amp x 3 Amp 2 Pole	22-42084**	**replaces 22-42077
13	Automatic Voltage Regulator	22-42071	
14	Rubber Mount	33-40007	

**PX-308K2 to PX-325K2
Junction Box, Three Phase, Marine**

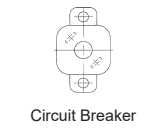
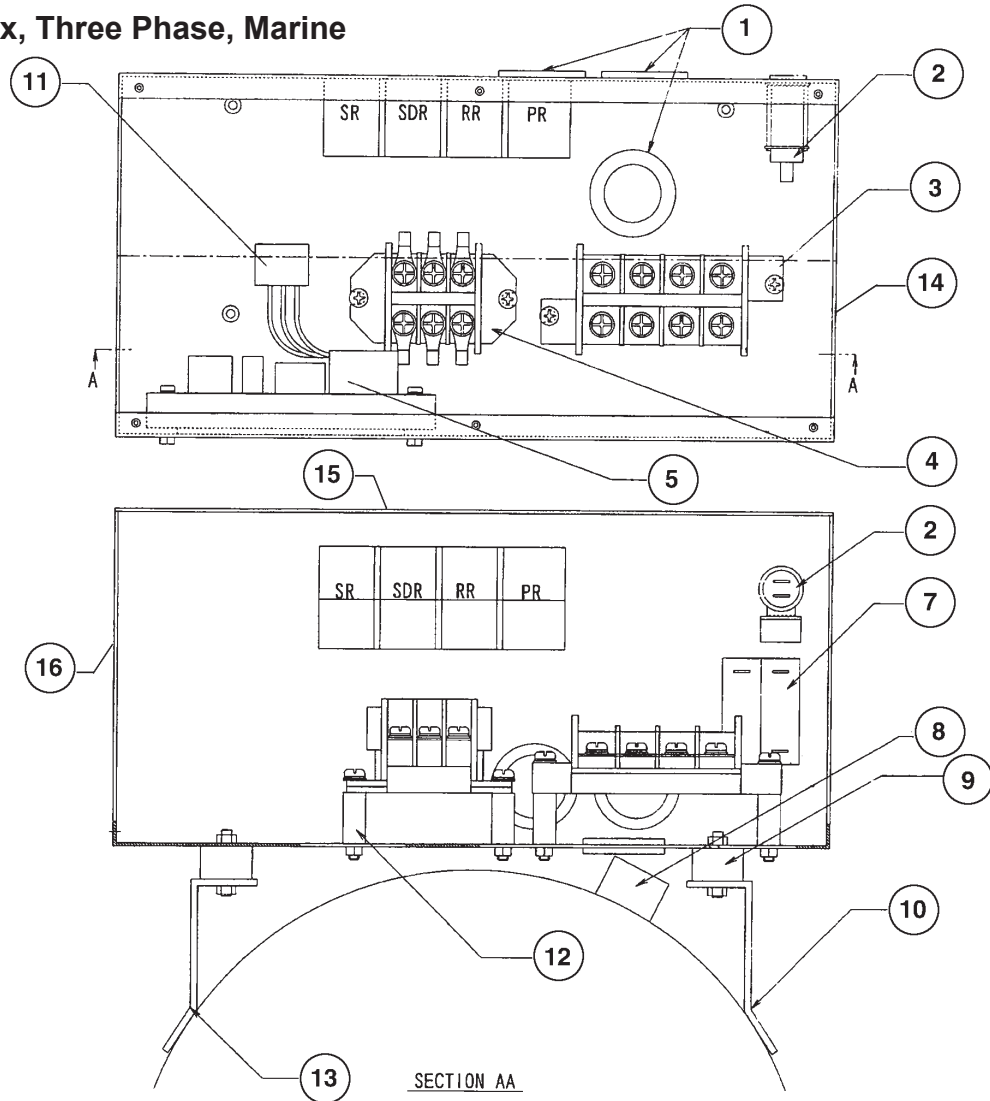

3T102-350

Key	Description	Part Number	
1	Grommet	NG-79-R	
2	DC Circuit Breaker 15 Amp	22-42043	
3	Terminal Strip	TE-K22-4	
4	Terminal	UK60-3J	*former # UKT60-3J
5	Automatic Voltage Regulator (DST-100-2FAK)	22-42071	
7	AC Circuit Breaker 2 Amp x 3 Amp 2 Pole	22-42084*	*replaces 22-42077
8	Rubber Tube		
9	Rubber Mount	33-40007 (4 ea.)	
10	Bracket, Junction Box	4T301-309	
11	Plug	3191-09P	
12	Spacer	4T301-181 (4 ea.)	
13	Bracket, Junction Box Mtg. - Left	4T301-310	
	Bracket, Junction Box Mtg. - Right	4T301-309	
14	Junction Box	3T303-290-2**	**replaces 3T303-290-1
15	Top Panel	4T301-108	
16	Side Panel	4T301-109 (2 ea.)	

PX-332K2
Junction Box, Three Phase, Marine

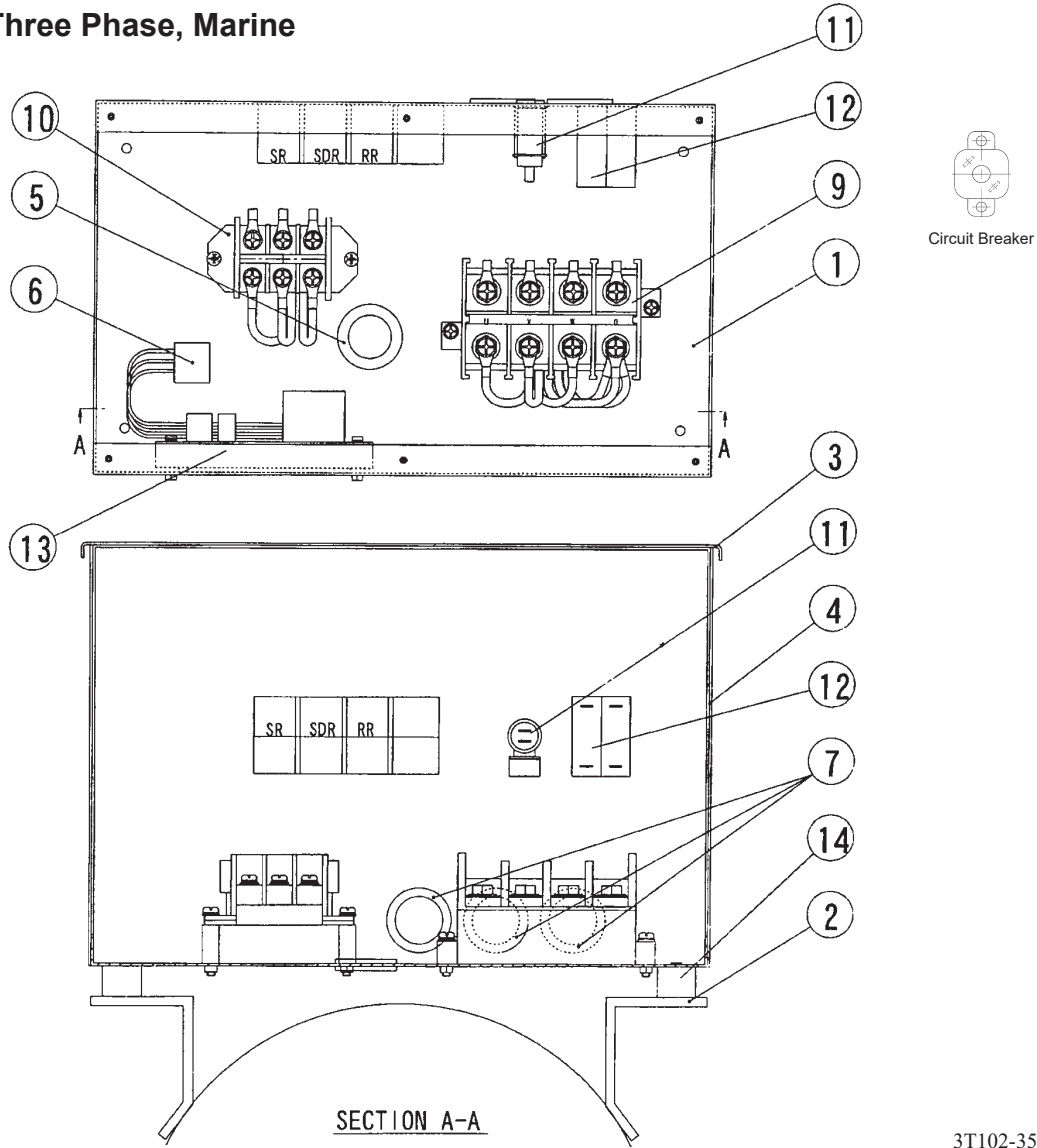

3T102-351

Key	Description	Part Number	
1	Junction Box	3T303-298-3*	*replaces 3T303-298-1
2	Bracket, Junction Box Mounting	3T302-782-1 (2 ea.)	
3	Top Panel	4T302-144	
4	Side Panel	4T302-859 (2 ea.)	
5	Grommet	NG-79-R**	**replaces 4M911-018
6	Plug	3191-09P	
7	Grommet	NG-79-R	
8	Spacer	4T301-310 (2 ea.)	
9	Terminal (for output)	22-45413	
10	Terminal (for output)	UKT100-3J	
11	DC Circuit Breaker 15 Amp	22-42043	
12	AC Circuit Breaker 2 Amp x 3 Amp 2 Pole	22-42084***	***replaces 22-42077
13	Automatic Voltage Regulator (DST-100-2FAK)	22-42071	
14	Rubber Mount	33-40007 (4 ea.)	

**PX-308K2 to PX-320K2
Junction Box, Single Phase, Industrial**

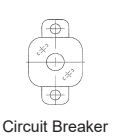
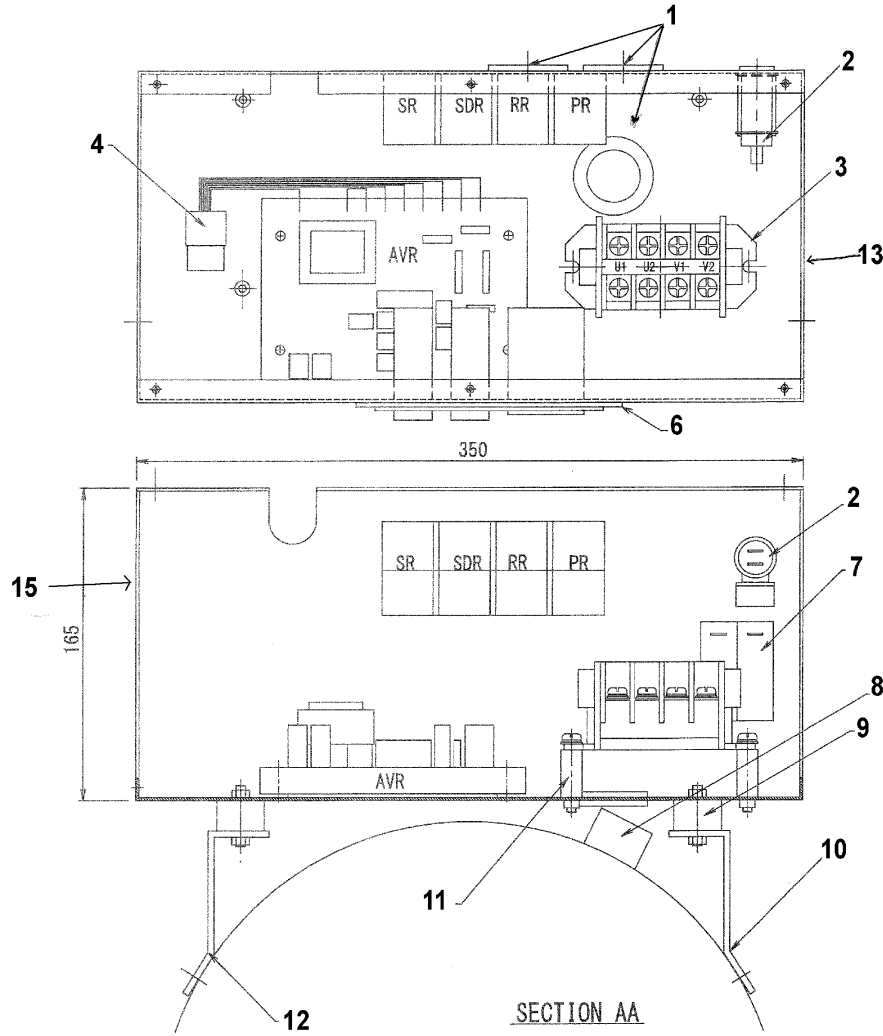

T102-450-1

Key	Description	Part Number
1	Grommet	NG-79-R
2	DC Circuit Breaker	22-42043
	Circuit Breaker 15A	22-40674
3	Terminal	22-42036
4	Plug	3191-09P
5	Automatic Voltage Regulator (DST-100-2FAK)	22-42071
6	Adapter Plate	4T303-712
7	AC Circuit Breaker 2 Amp x 3 Amp 2 Pole	22-42084*
8	Rubber Tube	
9	Rubber Mount	33-40007 (4 ea.)
10	Bracket, Junction Box Mtg. - Right	4T301-309
11	Spacer	4T301-181 (2 ea.)
12	Bracket, Junction Box Mtg. - Left	4T301-310
13	Junction Box	3T303-714
14	Top Panel	4T301-108
15	Side Panel	4T301-109 (2 ea.)

**PX-308K2 to PX-325K2
Junction Box, Three Phase, Industrial**

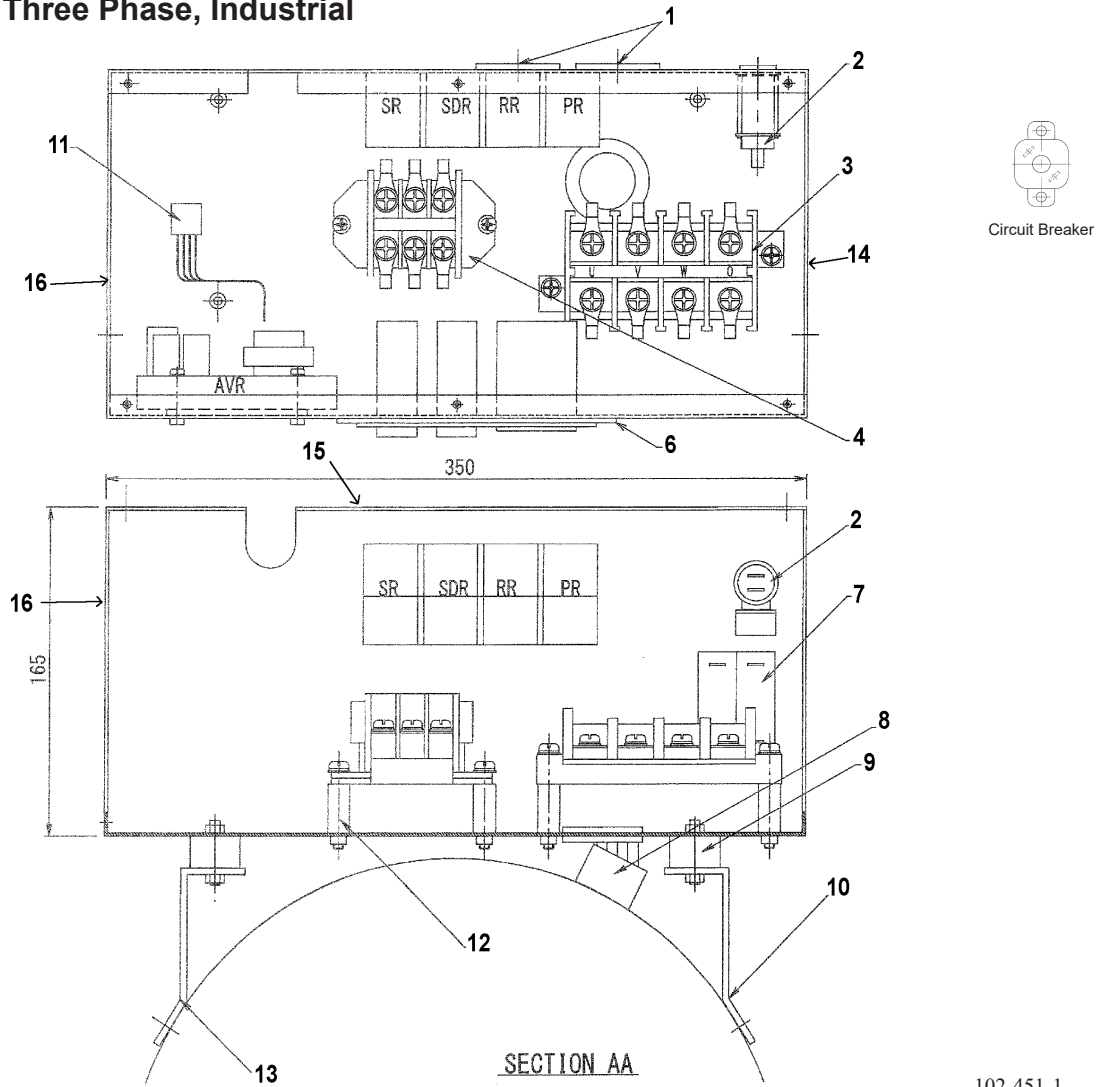

102-451-1

Key	Description	Part Number
1	Grommet	NG-79-R
2	DC Circuit Breaker 15 Amp	22-42043
3	Terminal Strip	TE-K22-4
4	Terminal	UK60-3J
5	Automatic Voltage Regulator (DST-100-2FAK)	22-42071
7	AC Circuit Breaker 2 Amp x 3 Amp 2 Pole	22-42084*
8	Rubber Tube	
9	Rubber Mount	33-40007 (4 ea.)
10	Bracket, Junction Box	4T301-309
11	Plug	3191-09P
12	Spacer	4T301-181 (4 ea.)
13	Bracket, Junction Box Mtg. - Left	4T301-310
	Bracket, Junction Box Mtg. - Right	4T301-309
14	Junction Box	3T303-716-1
15	Top Panel	4T301-108
16	Side Panel	4T301-109 (2 ea.)

**PX-308K2 - NL773L4E
Junction Box, Single Phase**

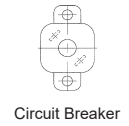
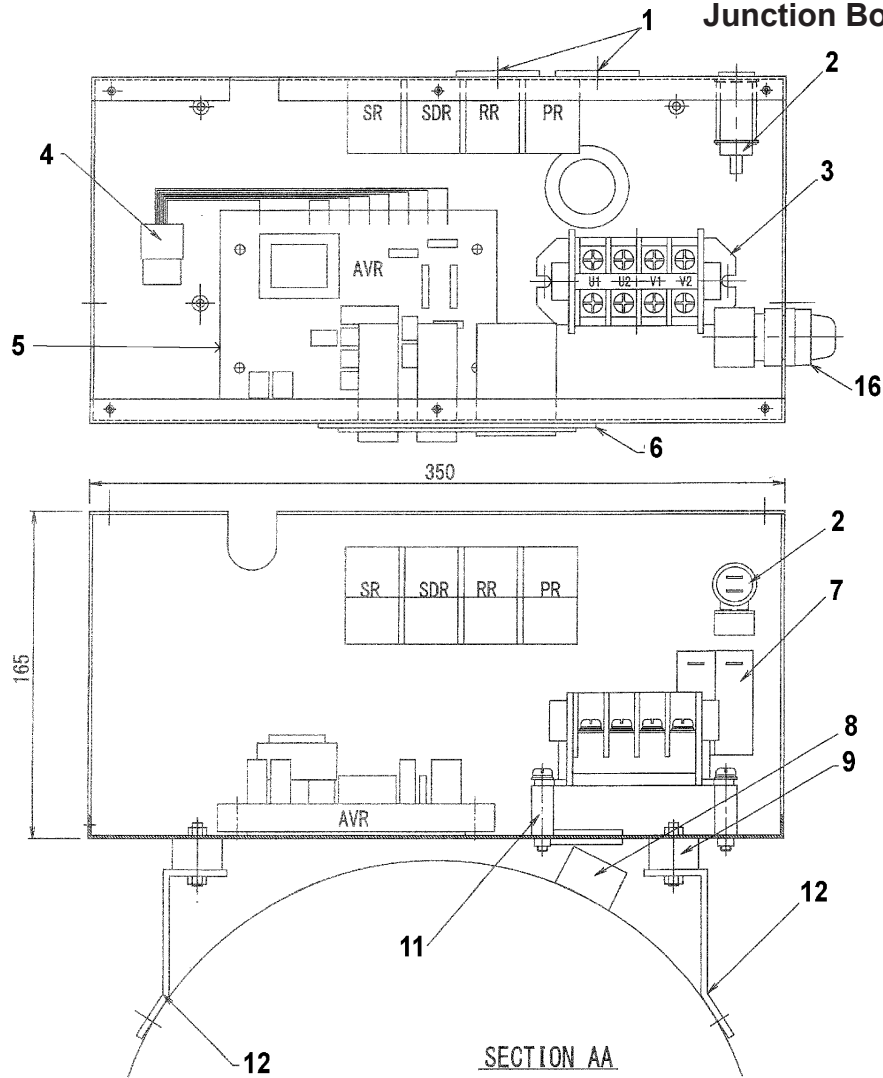

3T102-493

Key	Description	Part Number	
1	Grommet	NG-79-R	
2	DC Circuit Breaker	22-42043	
	DC Circuit Breaker	22-40674	
3	Terminal	22-42036	
4	Plug	3191-09P	
5	Automatic Voltage Regulator (DST-100-2FAK)	22-42071	
6	Adapter Plate	4T303-712	
7	AC Circuit Breaker 2 Amp x 3 Amp 2 Pole	22-42084*	
8	Rubber Tube		
9	Rubber Mount	33-40007 (4 ea.)	
10	Bracket, Junction Box Mtg. - Right	4T301-309	
11	Spacer	4T301-181 (2 ea.)	
12	Bracket, Junction Box Mtg. - Left	4T301-310	
13	Junction Box	3T303-714	* DC breaker
	Junction Box	3T304-014	
14	Top Panel	4T301-108	
15	Side Panel	4T301-109 (2 ea.)	
16	Lamp	APW211DR	

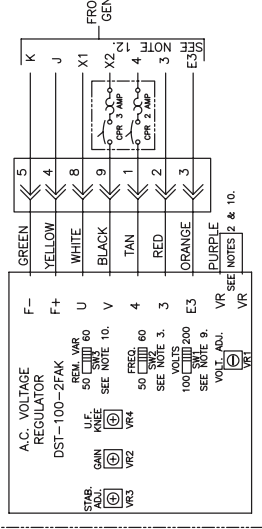
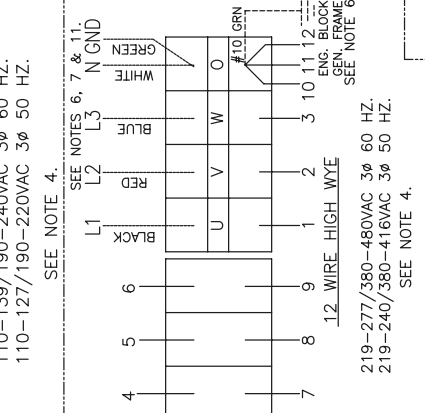
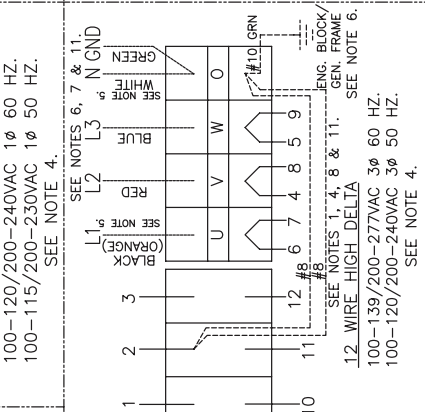
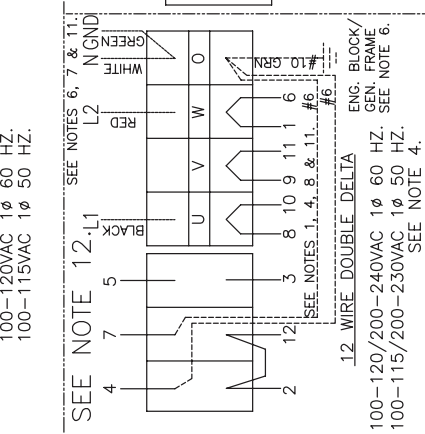
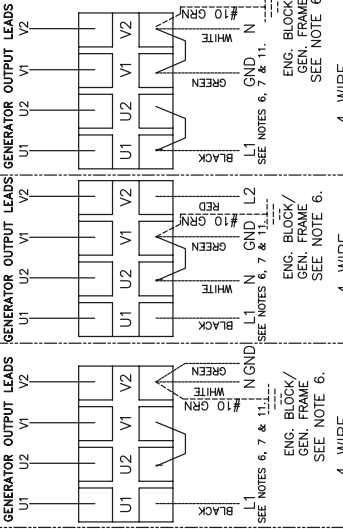
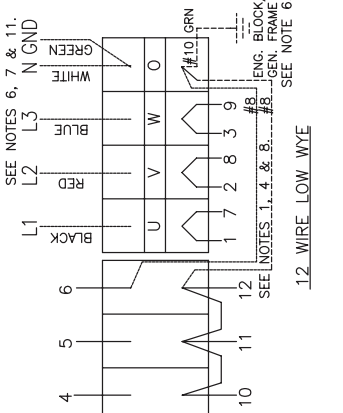
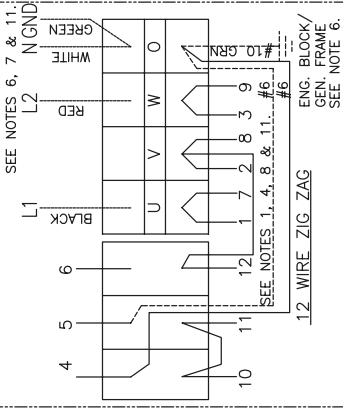
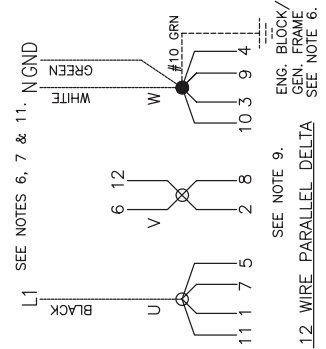

- NOTES:
1. ALL A.D.E. INSTALLED CONDUCTORS ARE TO BE TYPE MTW, 105°C, MULTISTRAND, 600VAC.
 2. FOR REMOTE VOLTAGE ADJUST RHEOSTAT CUT JUMPER AND SPICE INTO PURPLE LEADS.
 3. SET SW2 FOR CURRENT APPLICATION, (50 OR 60 HZ.) IF LOWER VOLTAGE IS NOT REQUIRED.
 4. DELETE NEUTRAL CONDUCTOR (AND JUMPER IF PRESENT), NEUTRAL IS PRESENT, IN ACCORDANCE WITH ARTICLE 215-8 OF THE NATIONAL ELECTRIC CODE.
 5. LINE ONE (HIGH LEG) TO BE MARKED ORANGE WHEN CUSTOMER'S DISCRETION. INDUSTRIAL GENSETS ARE TO BE GROUNDED IN ACCORDANCE WITH THE NATIONAL ELECTRICAL CODE AND ANY APPLICABLE LOCAL CODES.
 6. MARINE GENSETS ARE GROUNDED BY CUSTOMER, AT CUSTOMER'S DISCRETION. INDUSTRIAL GENSETS ARE TO BE GROUNDED IN ACCORDANCE WITH THE NATIONAL ELECTRICAL CODE AND ANY APPLICABLE LOCAL CODES.
 7. THICK HIDDEN (DASHED) LINES INDICATE CUSTOMER SUPPLIED AND CONNECTED MAIN OUTPUT CONDUCTORS. SIZING TO BE DETERMINED PER INSTALLATION.
 8. NEUTRAL CONDUCTORS SIZED FOR 33KW UNITS AT THE LOWEST LISTED VOLTAGE. CONSULT A.D.E. ENGINEERING FOR CONDUCTOR SIZING @ OTHER GENSET VOLTAGE/KW RATINGS.
 9. AVR INPUT SENSING SWITCH SW1 IS TO BE SET TO THE 200V POSITION FOR ALL APPLICATIONS EXCEPT STRAIGHT 100V-120V APPLICATIONS.
 10. SET SW3 PER APPLICATION IF REMOTE VOLTAGE ADJUST RHEOSTAT IS USED.
 11. TERMINAL BLOCKS WILL NOT ACCOMMODATE LARGER GAUGE CONDUCTORS. IF REQUIRED, REMOVE AFFECTED LEADS FROM TERMINAL BLOCK(S) AND MAKE CONNECTIONS USING BOLT, LOCK WASHER AND NUT. ISOLATE BY WRAPPING WITH ELECTRICAL TAPE.
 12. THE DOUBLE DELTA CONFIGURATION REQUIRES THE AVR TO BE REWIRED AS FOLLOWS: DISCONNECT LEADS 3 AND 4 FROM AVR. CONNECT LEAD 3 TO AVR TERM. 4 (THROUGH G.B.). CONNECT LEAD 4 TO AVR TERM. 3. DISCONNECT LEAD E3 FROM AVR AND ISOLATE. CONNECT AVR TERM. 5 TO MAIN INPUT BLOCK TERM. "W", USING A RED AWG 14 LEAD (SEE NOTE 1).

**AC Wiring Schematic - B-8280E
DST-100-2FAK, All Voltages**



4420 14th Ave. NW., Seattle WA 98107

Tel: (206) 789-3880 • 1-800-762-0165 • www.northern-lights.com

Northern Lights and Lugger are registered trademarks of Northern Lights, Inc.

© 2018 All rights reserved. Litho USA.