

MODELS	APPROX. WT. KG [lbs]	CENTER of GRAVITY mm[IN]			CENTER of GRAVITY with PMG mm[IN]		
		A	B	C	A	B	C
M1064T1.11 1800 RPM 60Hz 55kw 3Ø	931.68 [2054]	124.46 [4.90]	63.5 [2.5]	50.8 [2.0]	106.9 [4.21]	63.5 [2.5]	50.8 [2.0]
M1064T1.31 1800 RPM 60Hz 55kw 1Ø	972.50 [2144]	101.09 [3.98]	53.3 [2.1]	50.8 [2.0]	84.6 [3.33]	53.3 [2.1]	50.8 [2.0]
M1064T1.51 1500 RPM 50Hz 50kw 3Ø	931.68 [2054]	124.46 [4.90]	63.5 [2.5]	50.8 [2.0]	106.9 [4.21]	63.5 [2.5]	50.8 [2.0]
M1064T1.71 1500 RPM 50Hz 50kw 1Ø	972.50 [2144]	101.09 [3.98]	53.3 [2.1]	50.8 [2.0]	84.6 [3.33]	53.3 [2.1]	50.8 [2.0]

NOTE:
 1) CENTER OF GRAVITY VALUES DO NOT INCLUDE PTO/CLUTCH ASSY.
 2) PTO ADAPTER/CLUTCH ASSY (ONLY) WEIGHS APPROX. 96lbs (43.5 kg)
 3) CUSTOMER MUST RECALCULATE CG FOR ADDITION OF HYDRAULIC PUMP.

LEGEND		LEGEND	
ITEM	DESCRIPTION	ITEM	DESCRIPTION
1	EXPANSION TANK	11	HYDROLASTIC MOUNT
2	COOLANT FILL	12	ALTERNATE DIPSTICK LOCATION (OPTION)
3	RAW WATER PUMP INLET (Ø1.25 [Ø31.8])	13	4" WET EXHAUST ELBOW (OPTION)
4	FUEL FILTER	14	CLOSED CRANKCASE VENTILATION SYSTEM
5	CRANKCASE OIL DIPSTICK	15	RAW WATER OUTLET TUBE (Ø1.25"[31.8]) - WET EXHAUST.
6	CRANKCASE OIL FILLER	15A	RAW WATER OUTLET (Ø1.25"[31.8]) - DRY EXHAUST.
7	CRANKCASE OIL FILTER	16	PTO/CLUTCH STD MTG FACE, SAE J744C, B OR C OR 2 OR 4 BOLT (OPTION)
8	AIR INLET FILTER	17	PMG COVER - (OPTION, AS REQUIRED, BOTH STYLES SHOWN)
9	HEAT EXCHANGER	18	FUEL INLET / RETURN (3/8"NPT)
10	ENGINE OIL DRAIN 1/2" NPT	19	DRY EXHAUST ELBOW 4" 150# STD. FLG
		20	CONNECTION FOR WATER HEATER B= HOT WATER OUT A= RETURN TO ENGINE.

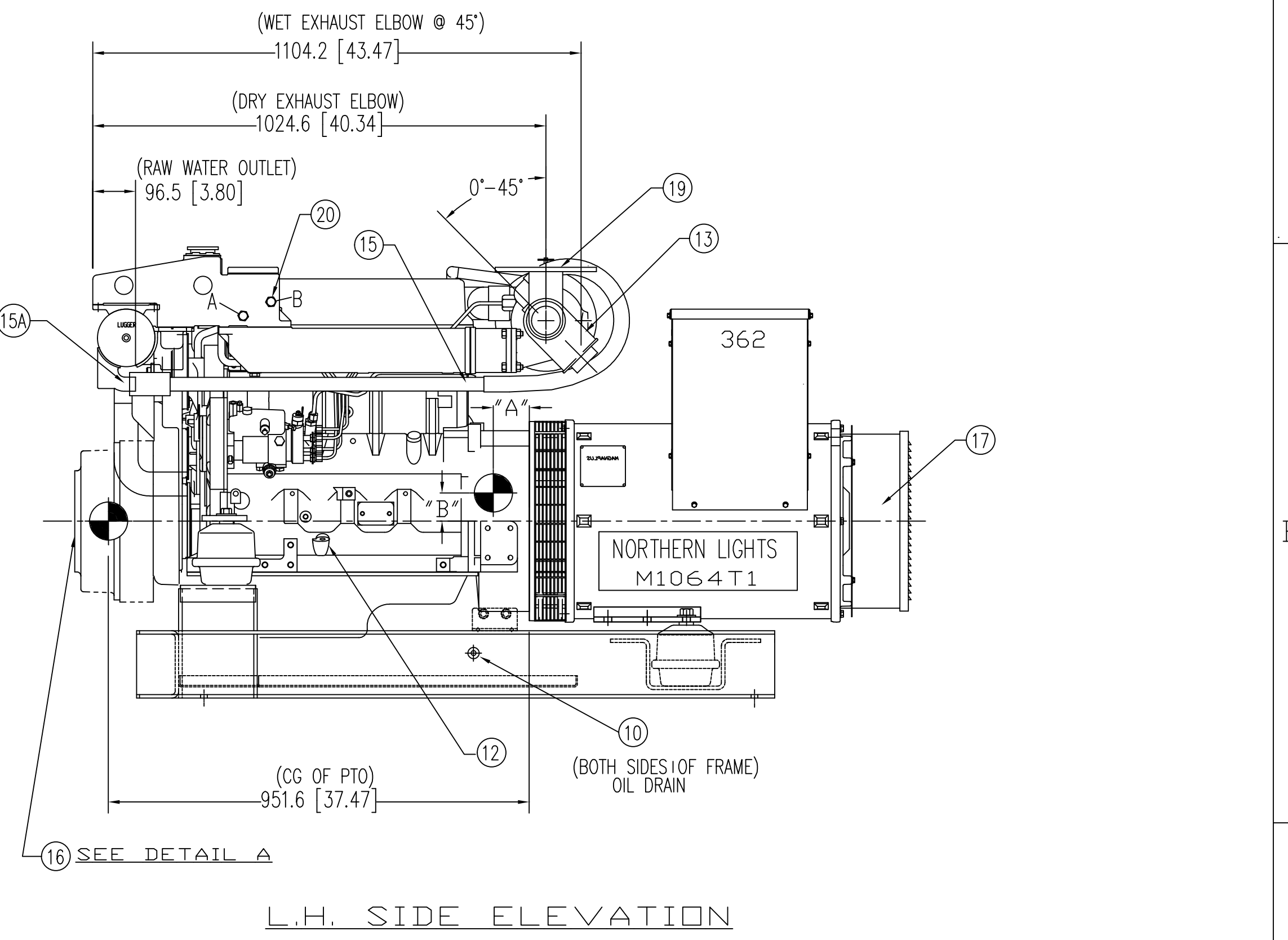
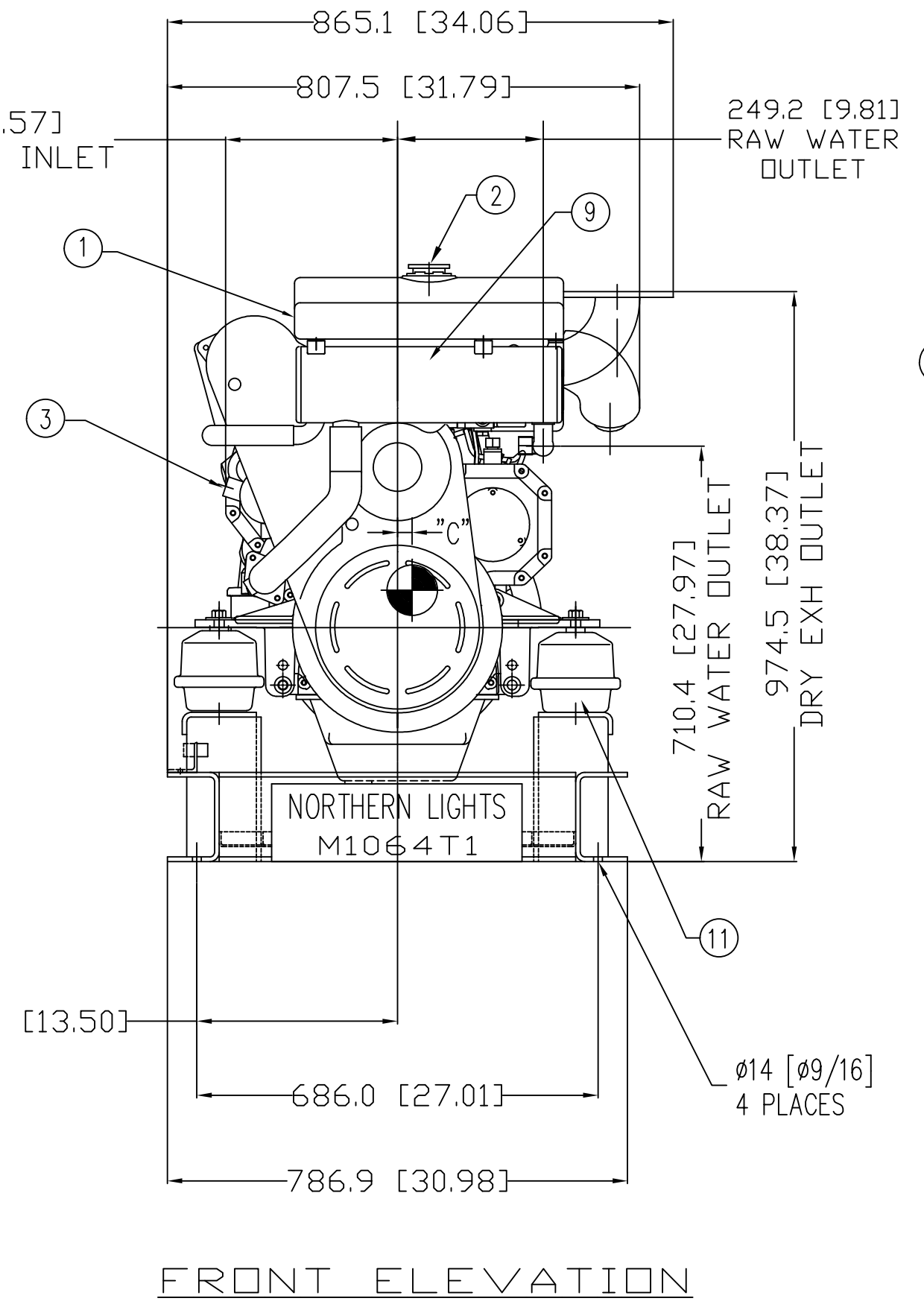
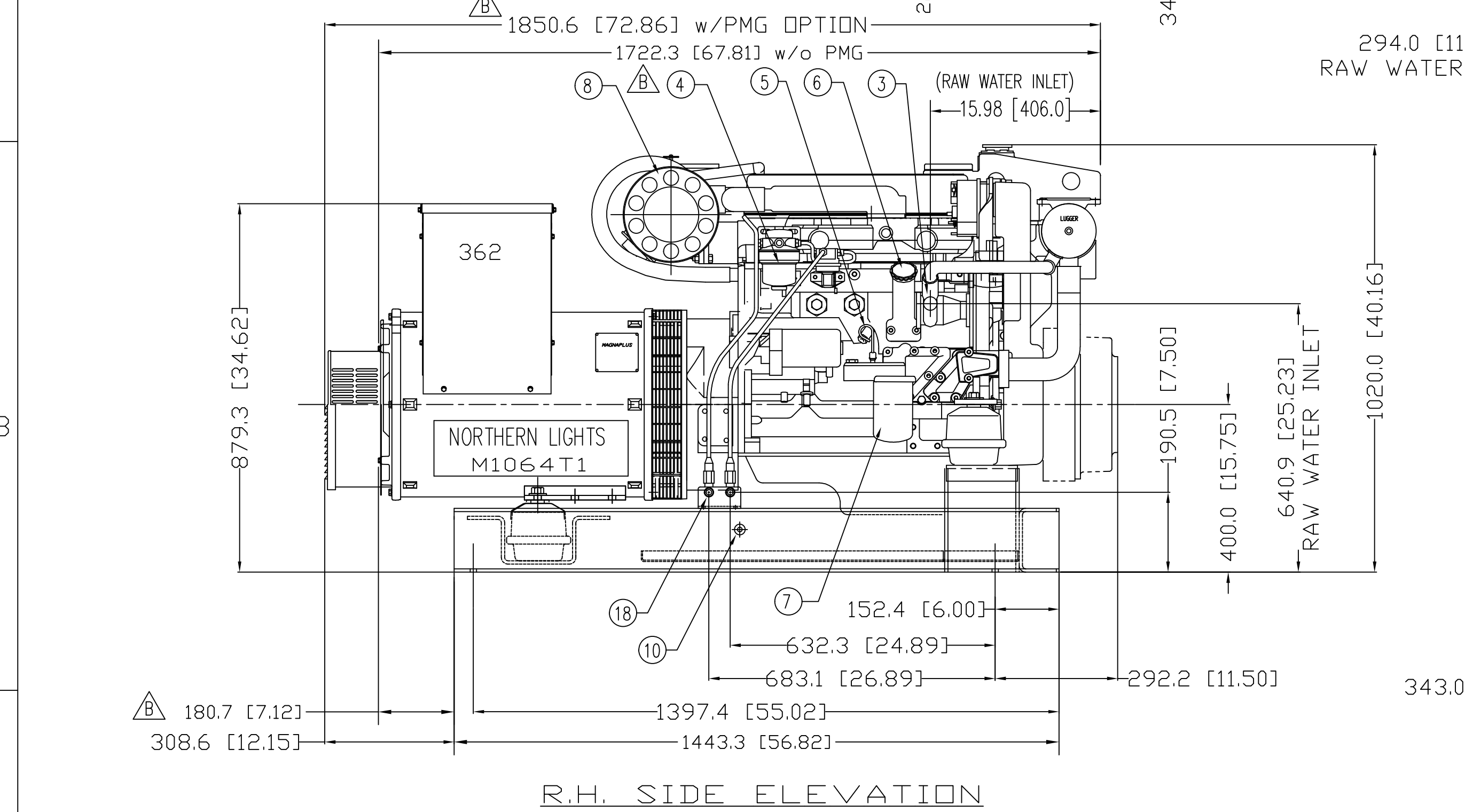
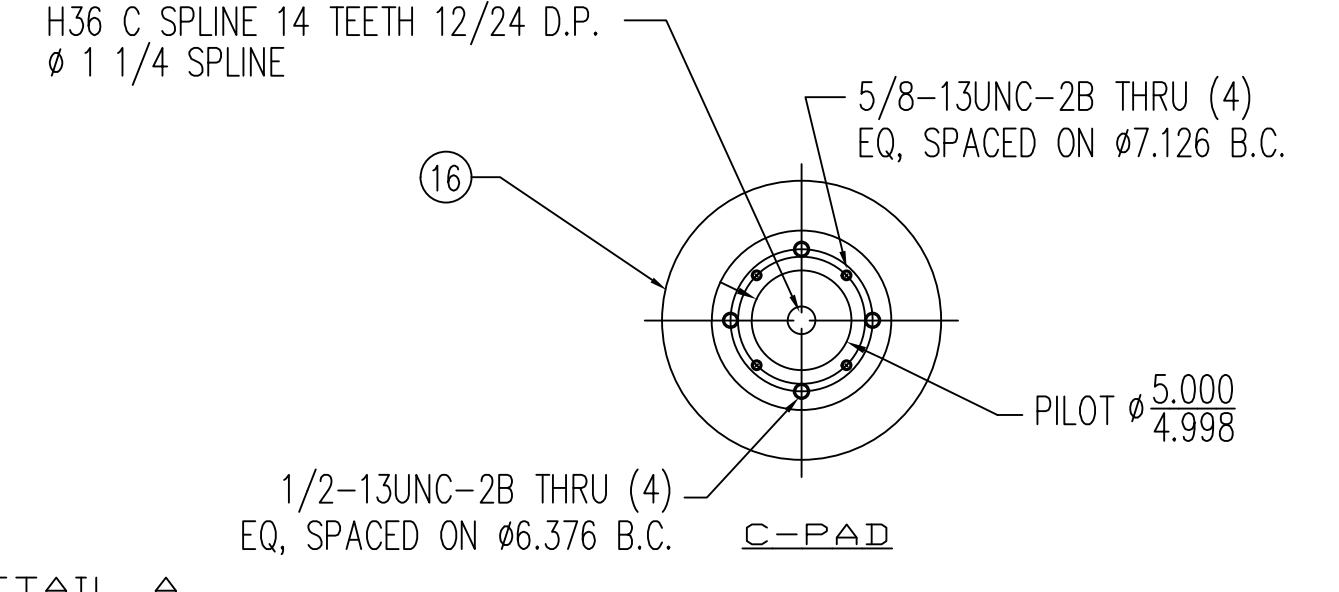
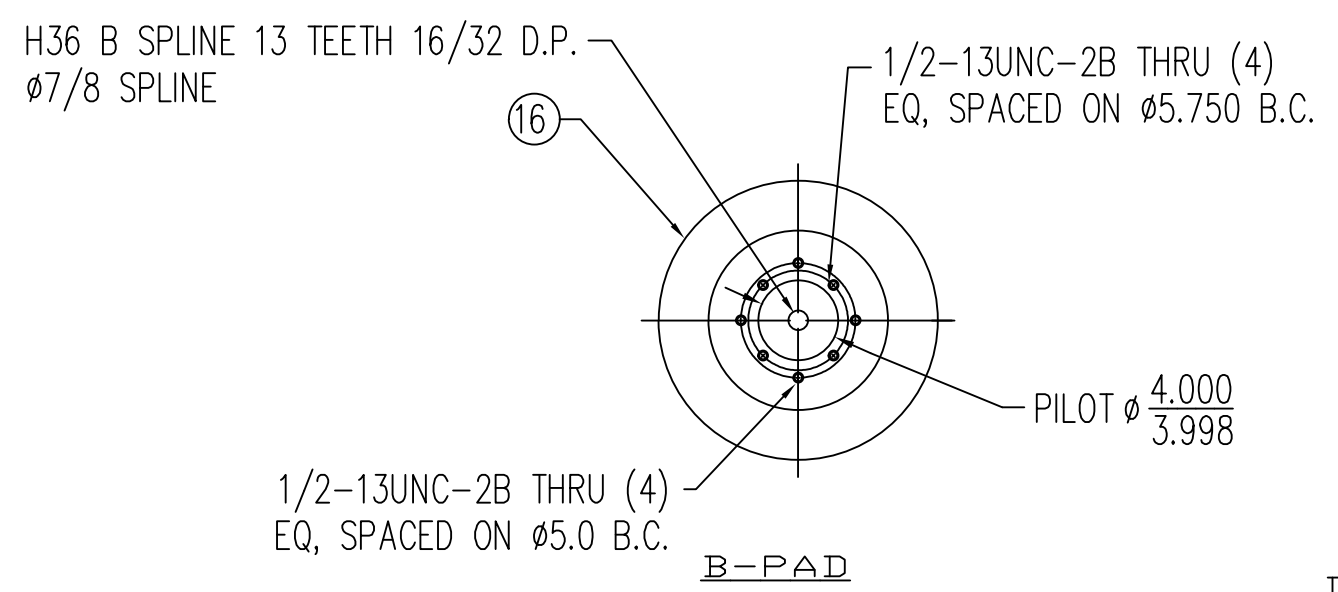
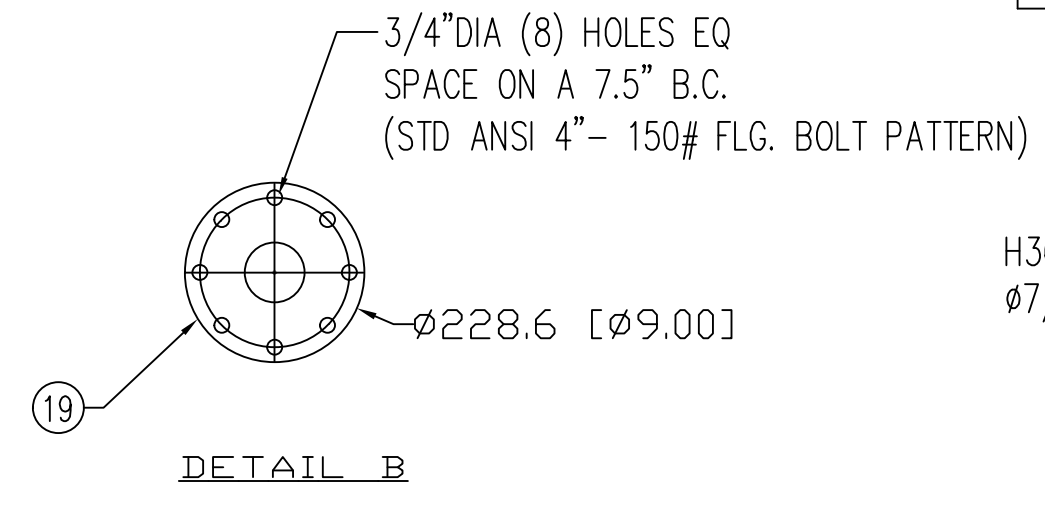
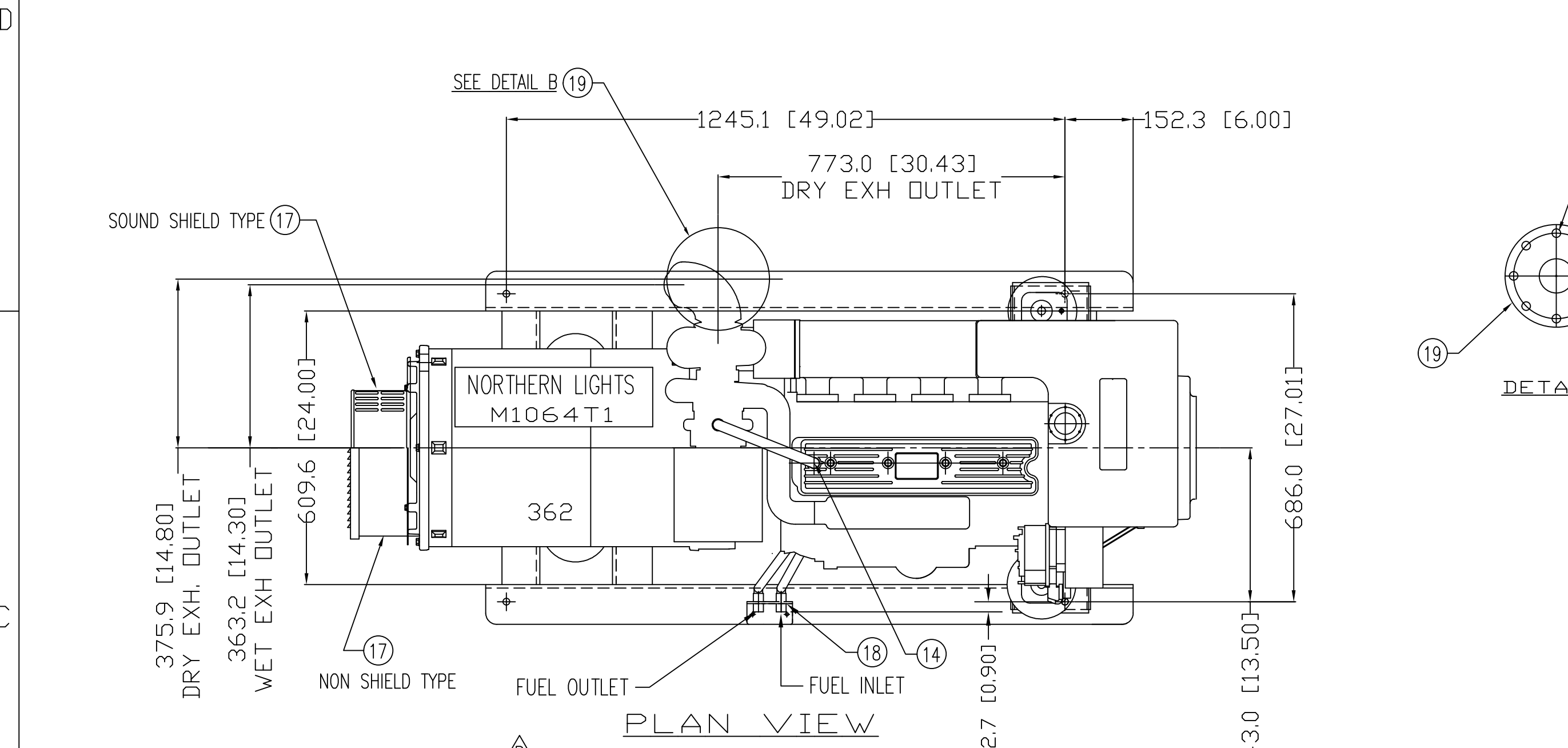

THE DIMENSIONS ON THIS DRAWING ARE SUBJECT TO CHANGE PLEASE CONTACT ADE TO BE SURE YOU HAVE THE MOST CURRENT REVISION.

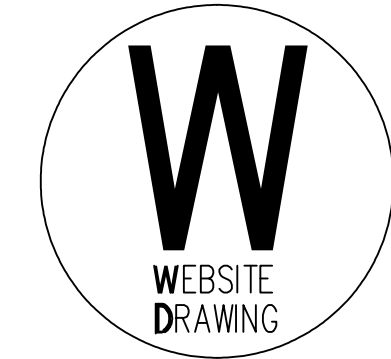

SYMBOL	DATE	DESCRIPTION	BY	CHECKED
C	8/5/04	CORRECTED DIME TO SHOW AS MMEINCHJ IN LH ELEVATION	LTP	
B	6/3/04	ADDED DIMS AND REFERENCES TO DAL WITH/WITHOUT PMG OPTION	LTP	
A	5/21/04	UPDATED APPLICATION TABLE, CORRECTED WEIGHTS AND CG	LTP	

REVISIONS		
DRAWN:	DATE	DESCRIPTION
LTP	5/10/04	

SCALE:	1:10 (.1" = 1")
SHEETS:	1 OF 1
UNITS OF MEASURE:	MM [INCH]
REVISE ON CAD ONLY	

TITLE:	INSTALLATION DIMENSIONS
P/N:	M1064T1/362PSL/3Ø/1Ø/60/50 Hz/MECH FI/ H.E./HYDRO MT.
DWG. NO.:	D-3684
REV.:	C