

8

7

6

5

4

3

2

1

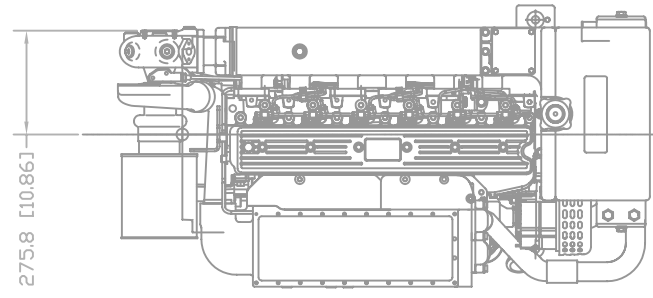

PLAN VIEW

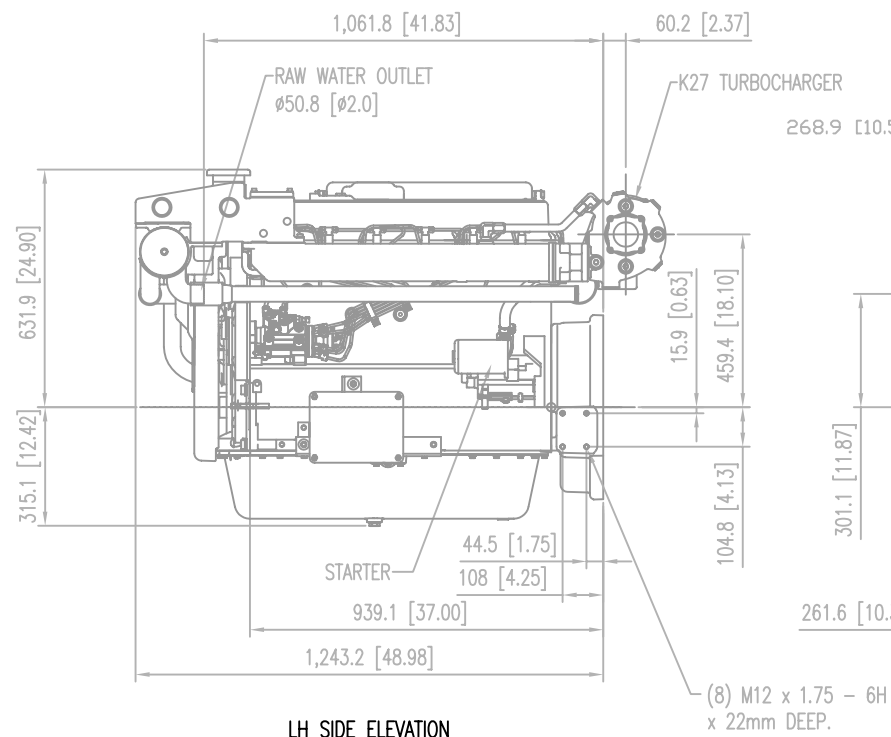

LH SIDE ELEVATION

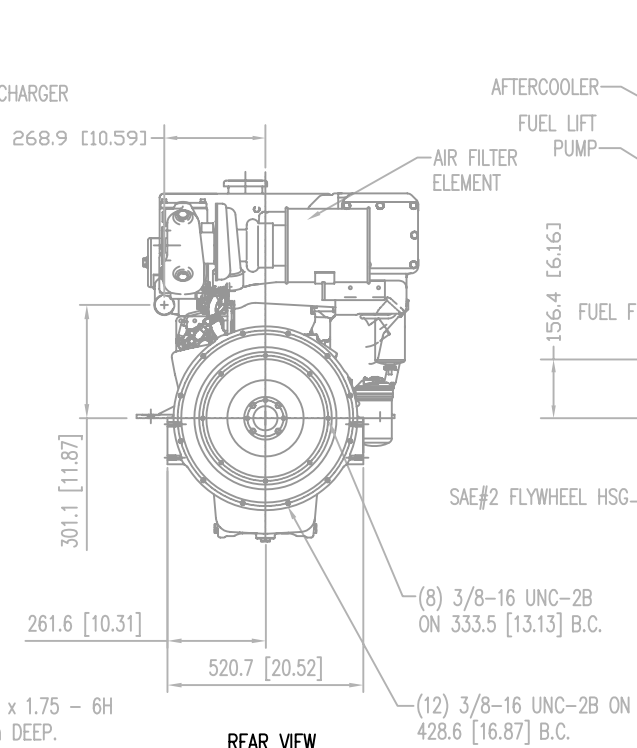

REAR VIEW

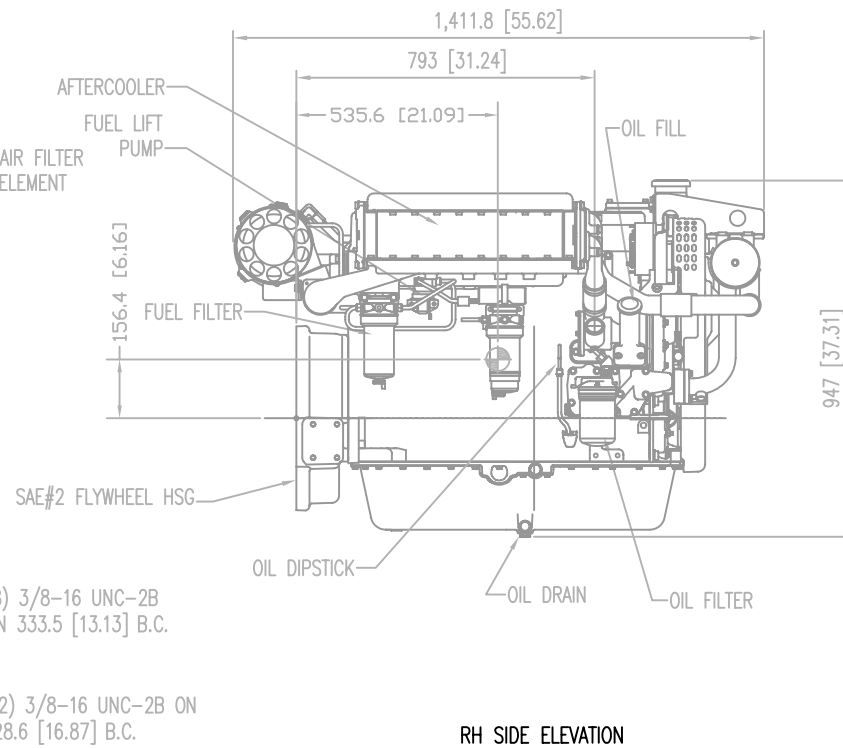

RH SIDE ELEVATION

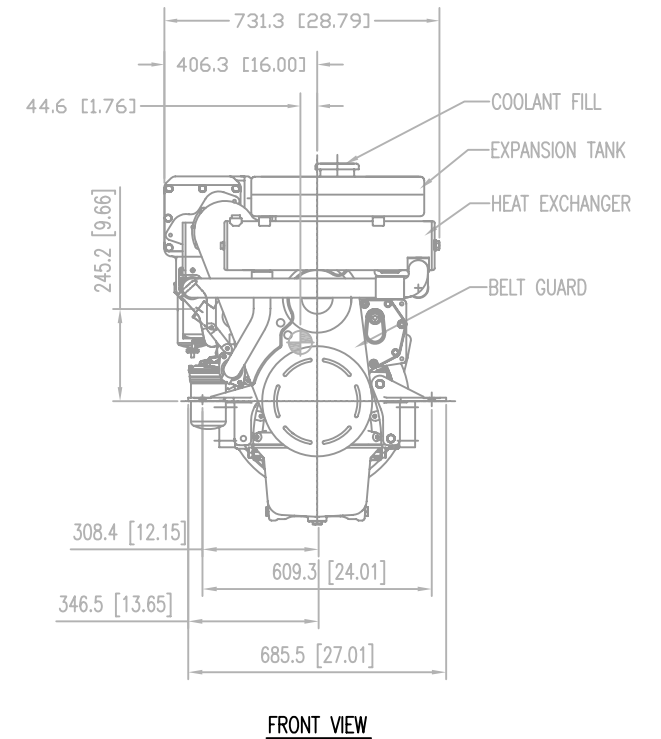

FRONT VIEW

TOLERANCES UNLESS OTHERWISE SPECIFIED		REVISIONS	
JOB: ±	CAD	DATE: 7/16/04	TITLE: ENGINE ARRANGEMENT DRAWING
XXX: ±	REVISE ON CAD ONLY	SCALE: 1:10	L/110004 / 2 VALVE / HEAT EXCHANGER
ANGULAR: ±	THIRD ANGLE PROJECTION	SHEETS: 1 OF 1	P/N: D-3738
		DATE OF REVISION: MM/DD	REV: -

ALASKA DIESEL ELECTRIC
 4420 14th AVE. N.W., P.O. BOX 70543
 SEATTLE, WA 98107 (206) 789-3880

8

7

6

5

4

3

2

1