

GENERATOR APPLICATION TABLE			
M673L3	6 kW	1800 RPM	1 PHASE 60 HZ.
M673L3	5 kW	1500 RPM	1 PHASE 50 HZ.
M673LD3	5 kW	1800 RPM	1 PHASE 60 HZ.
M673LD3	4.5 kW	1500 RPM	1 PHASE 50 HZ.

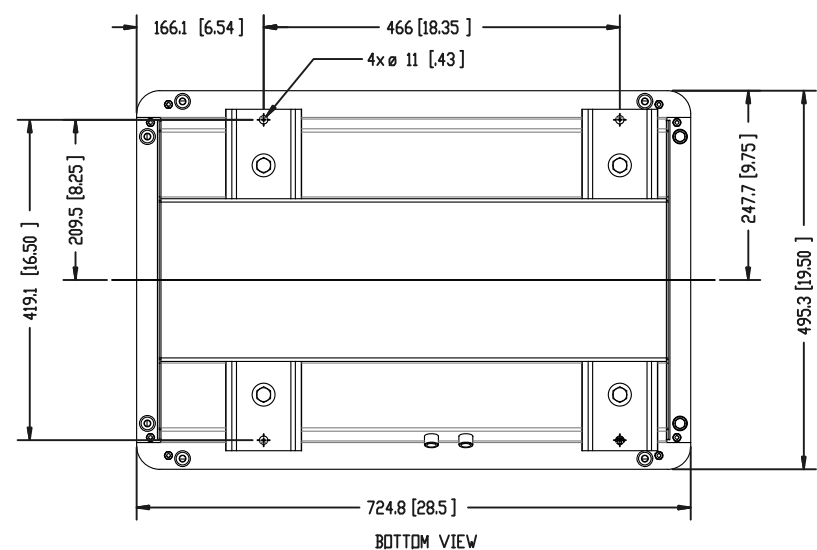

THE DIMENSIONS ON THIS DRAWING ARE SUBJECT TO CHANGE. PLEASE CONTACT NORTHERN LIGHTS INC TO BE SURE YOU HAVE THE MOST CURRENT REVISION.

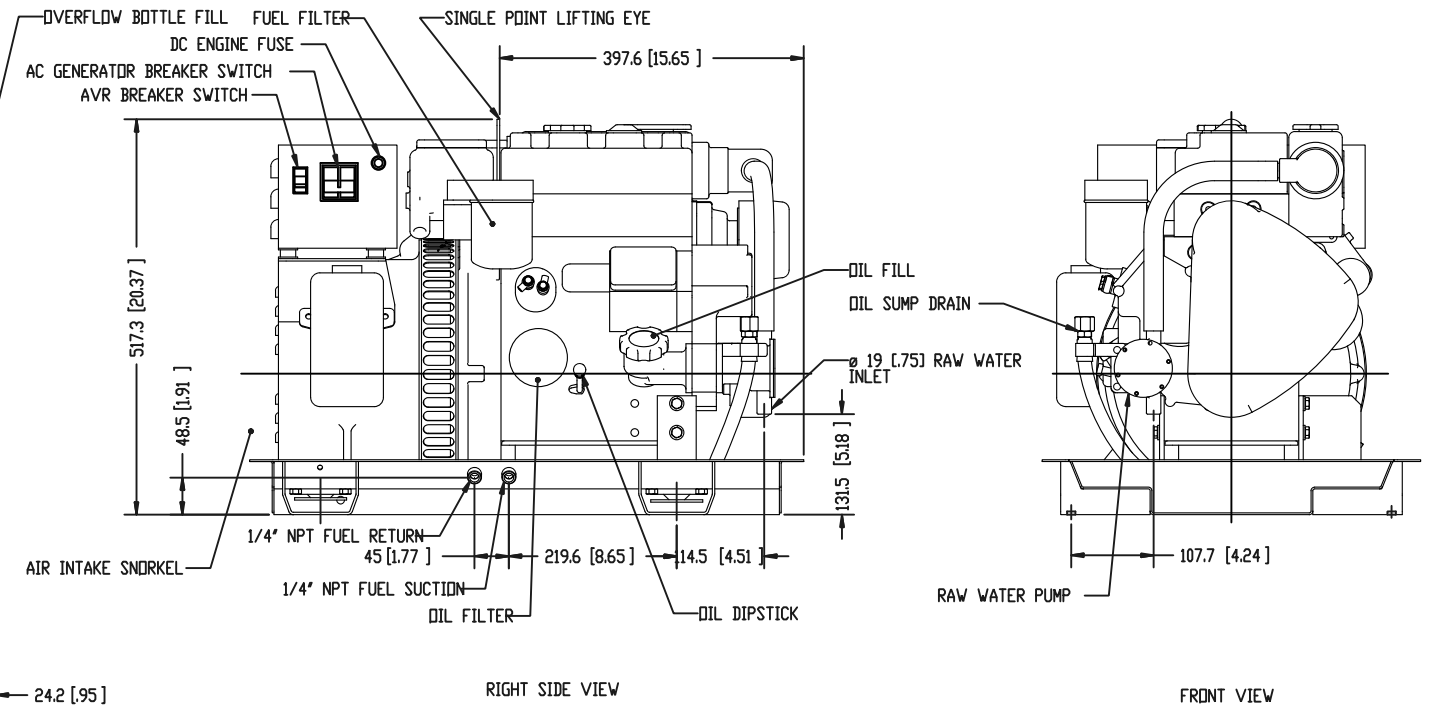
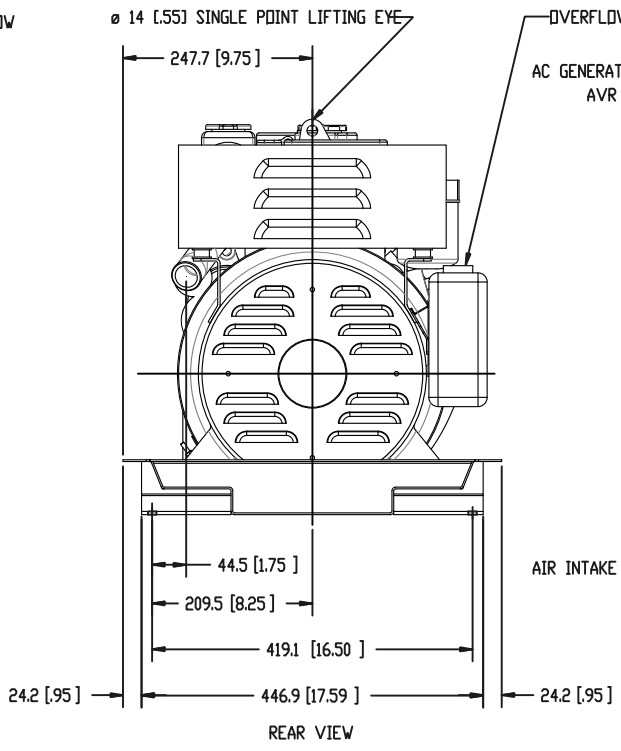
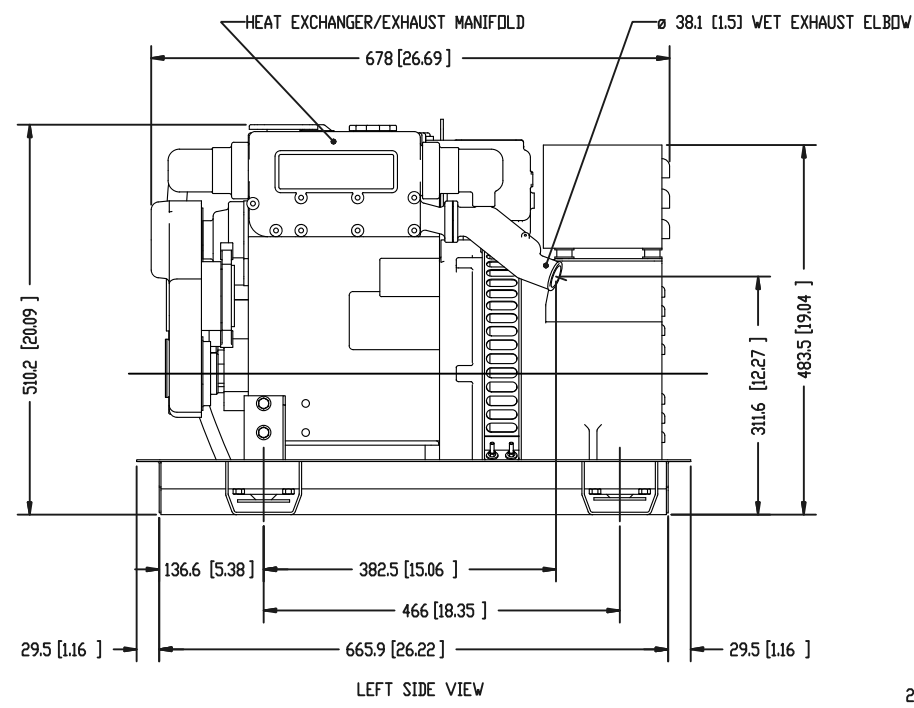
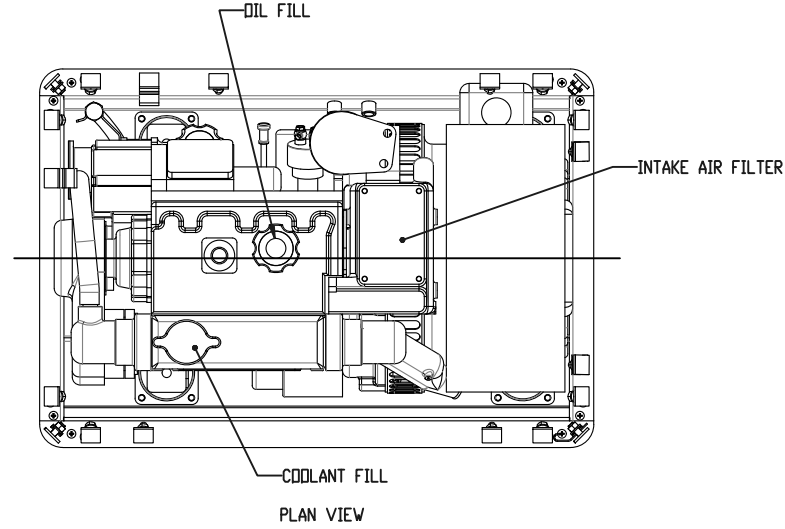
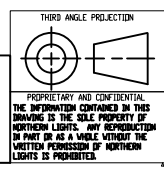

UNLESS OTHERWISE SPECIFIED DIMENSIONS ARE IN MILLIMETERS	NAME	DATE	
TOLERANCES:	DRAWN	LTP	5/19/2000
ANGULAR:	CHECKED		
MACH ± 0.5°	ENG APPR.		
BEND ± 1.0°	MFG APPR.		
X ± 0.05	QA		
XX ± 0.03	COMMENTS:		
INTERPRET GEOMETRIC TOLERANCING PER ASME Y14.5M			
MATERIAL:			
FINISH:			
DO NOT SCALE			

NORTHERN LIGHTS		4420 14th AVE. N.W. Seattle, WA 98107 (206) 789-3880 www.northern-lights.com	
TITLE: INSTALLATION DIMENSIONS			
M673L3/M673LD3			
SIZE	PART NO.	DWG. NO.	REV.
D		D-4449	
SCALE: 1:5	WEIGHT: 171 kg [377 LBS.]	SHEET 1 OF 1	