

MODEL	RATING	FREQUENCY	PHASE
M40C3	40 kW	60 Hz	3

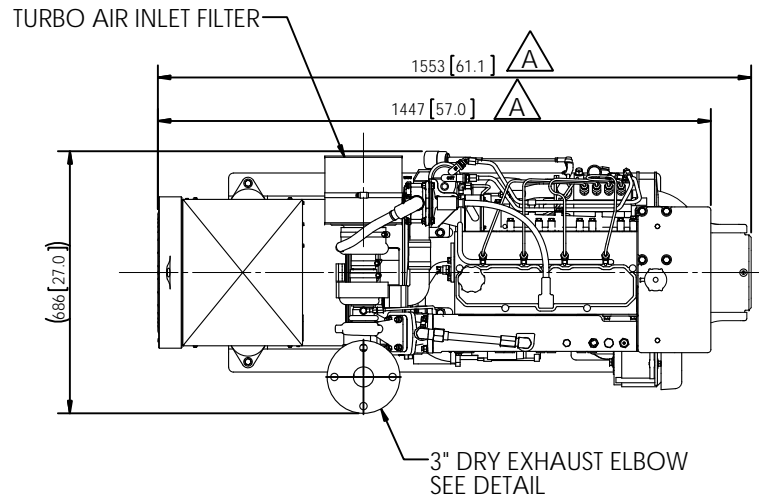

PLAN

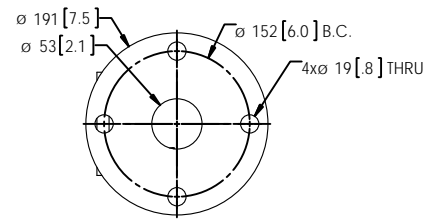

EXHAUST ELBOW DETAIL

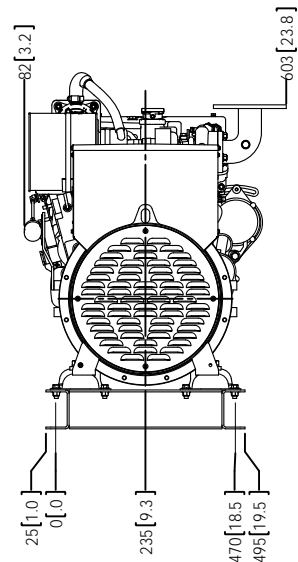
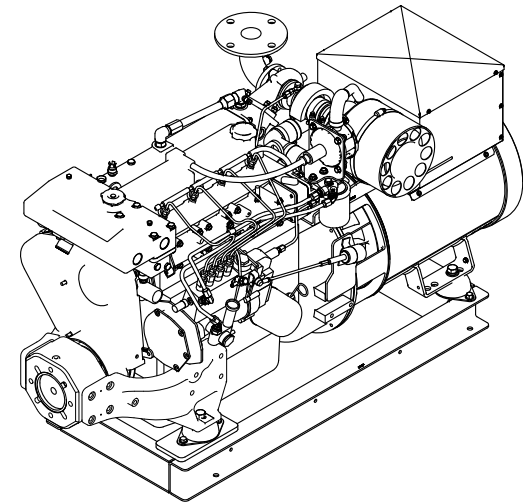

REAR

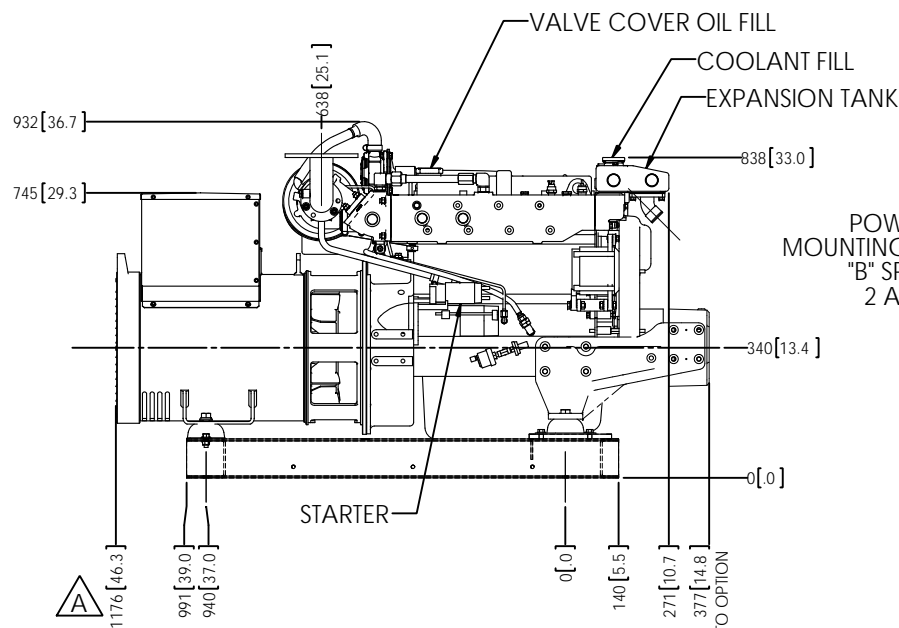

RIGHT SIDE

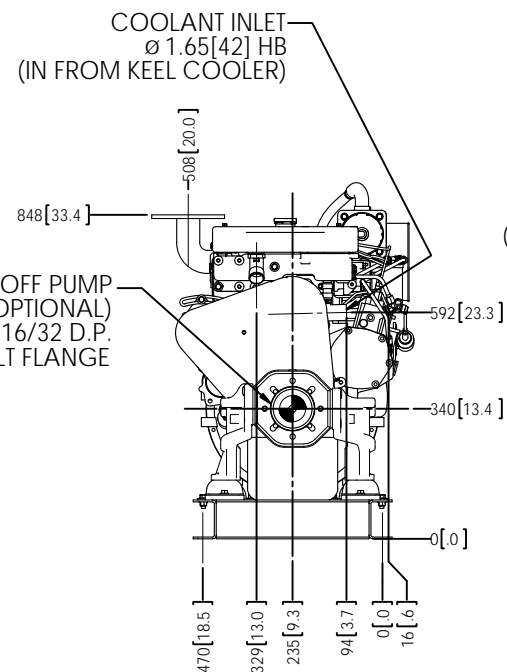

FRONT

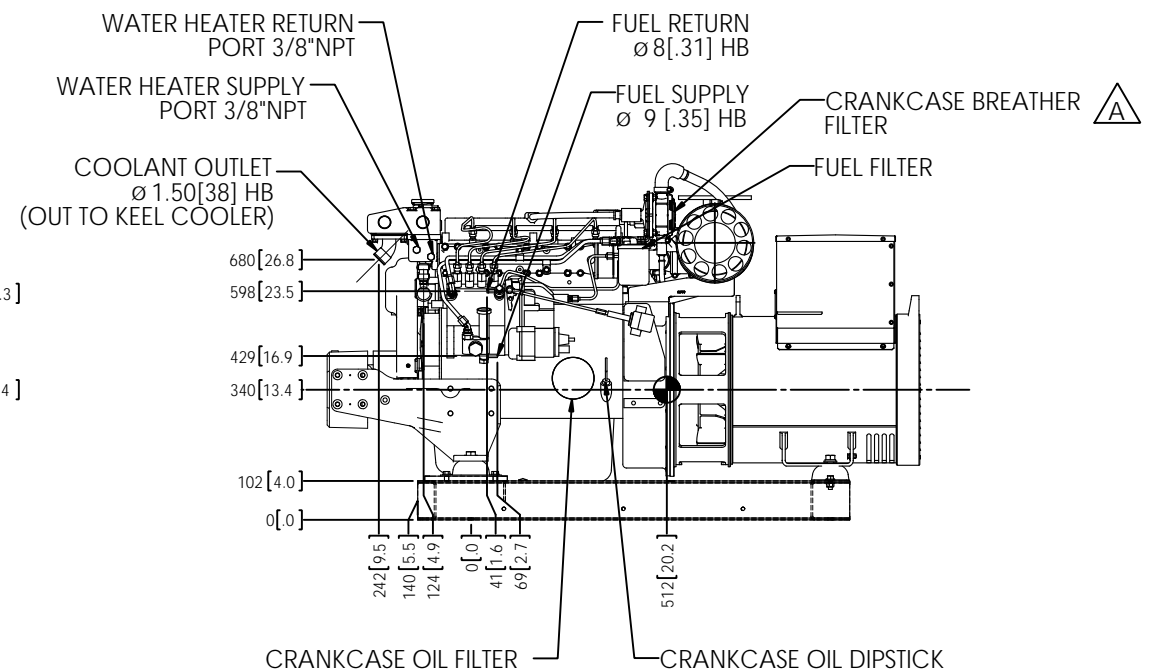

LEFT SIDE (SERVICE SIDE)

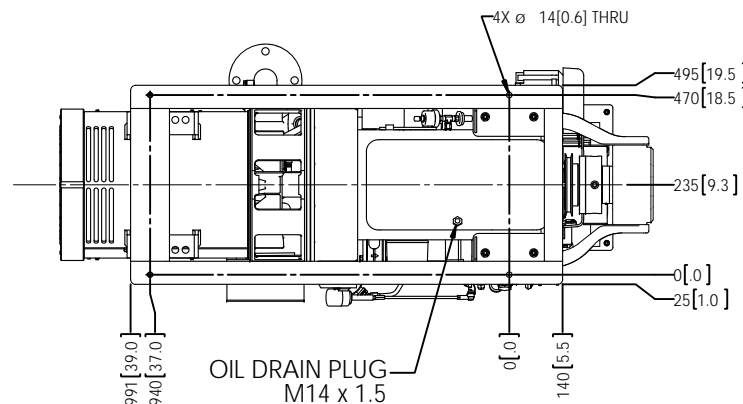

BOTTOM

NOTES

- WEIGHTS: GENSET - 621 kg [1370 lbs]  
GENSET W/PTO - 653 kg [1440 lbs]
- WEIGHTS ARE WITH OIL, NO COOLANT.
- C.G. DOES NOT INCLUDE PTO ASSEMBLY.

THE DIMENSIONS ON THIS DRAWING ARE SUBJECT TO CHANGE. PLEASE CONTACT NORTHERN LIGHTS INC. TO BE SURE YOU HAVE THE MOST CURRENT REVISION.

REV.	DESCRIPTION	DATE	BY	CHECKED
A	DRAWING UPDATED TO SHOW SHORTER GENERATOR AND RELOCATED CRANKCASE BREATHER FILTER. ECN 3689	12/14/2015	MG	TAH
REVISIONS				

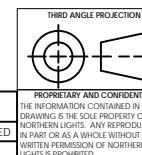

UNLESS OTHERWISE SPECIFIED: DIMENSIONS ARE IN MILLIMETERS TOLERANCES: ANGULAR: MACH: ±0.5° BEND ± 1.0° X = ± 2 XX = ± 1		NAME	DATE	<p>4420 14th AVE. N.W. Seattle, WA 98107 (206) 789-3880 www.northern-lights.com</p>
DRAWN	MG	05/13/14		
CHECKED	LTP	07/17/14		
ENG APPR.				
MFG APPR.				TITLE: <b>INSTALLATION DIMENSIONS</b> <b>M40C3.24</b>
MATERIAL:		COMMENTS:		SIZE: <b>D</b> PART NO.:
FINISH:				DWG. NO. <b>D-4755</b> REV <b>A</b>
DO NOT SCALE				SCALE: 1:10 WEIGHT: SHEET 1 OF 1