

PLAN

ESTIMATED WEIGHTS		
ITEM	kg	LBS
GENSET (W/COOLANT & OIL)	2991	6594
SOUND ENCLOSURE	414	913
COMPOUND MOUNTS	48	105
C-SPLINE PTO	75	165
D-SPLINE PTO	135	298

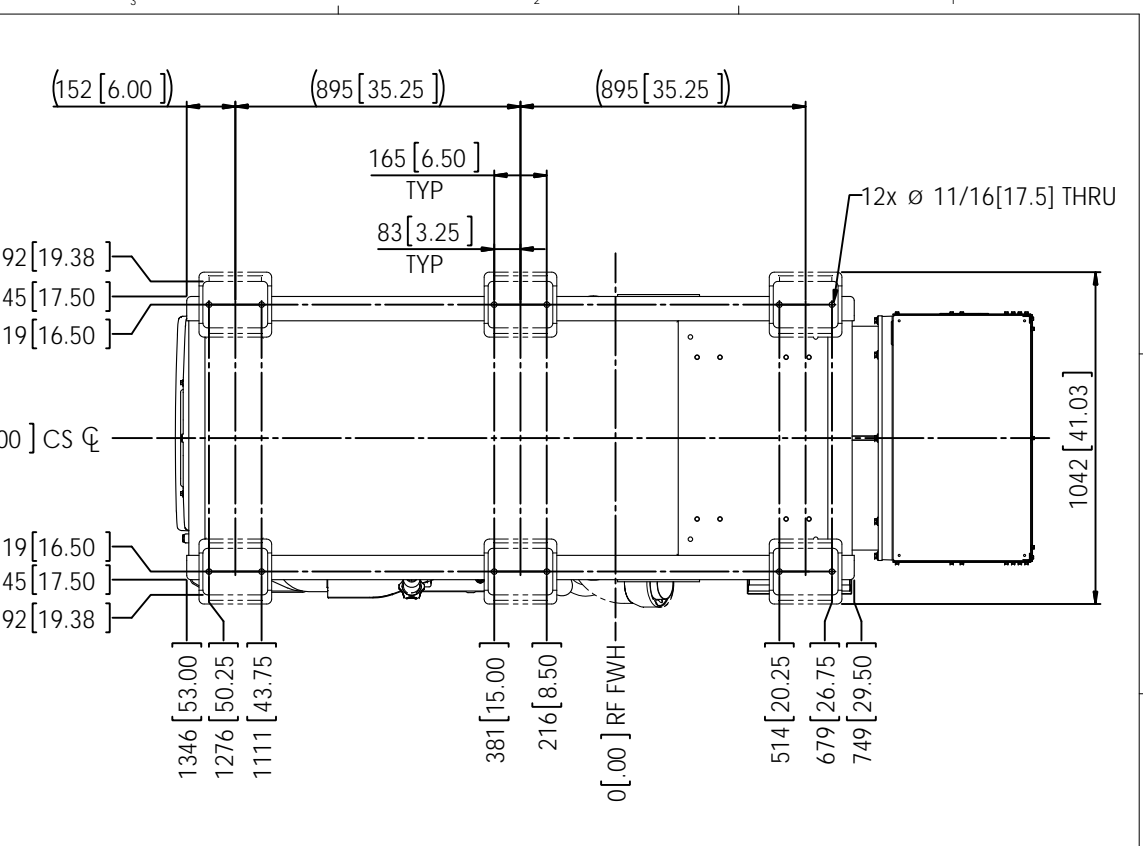

OPTIONAL COMPOUND MOUNT BOLT PATTERN

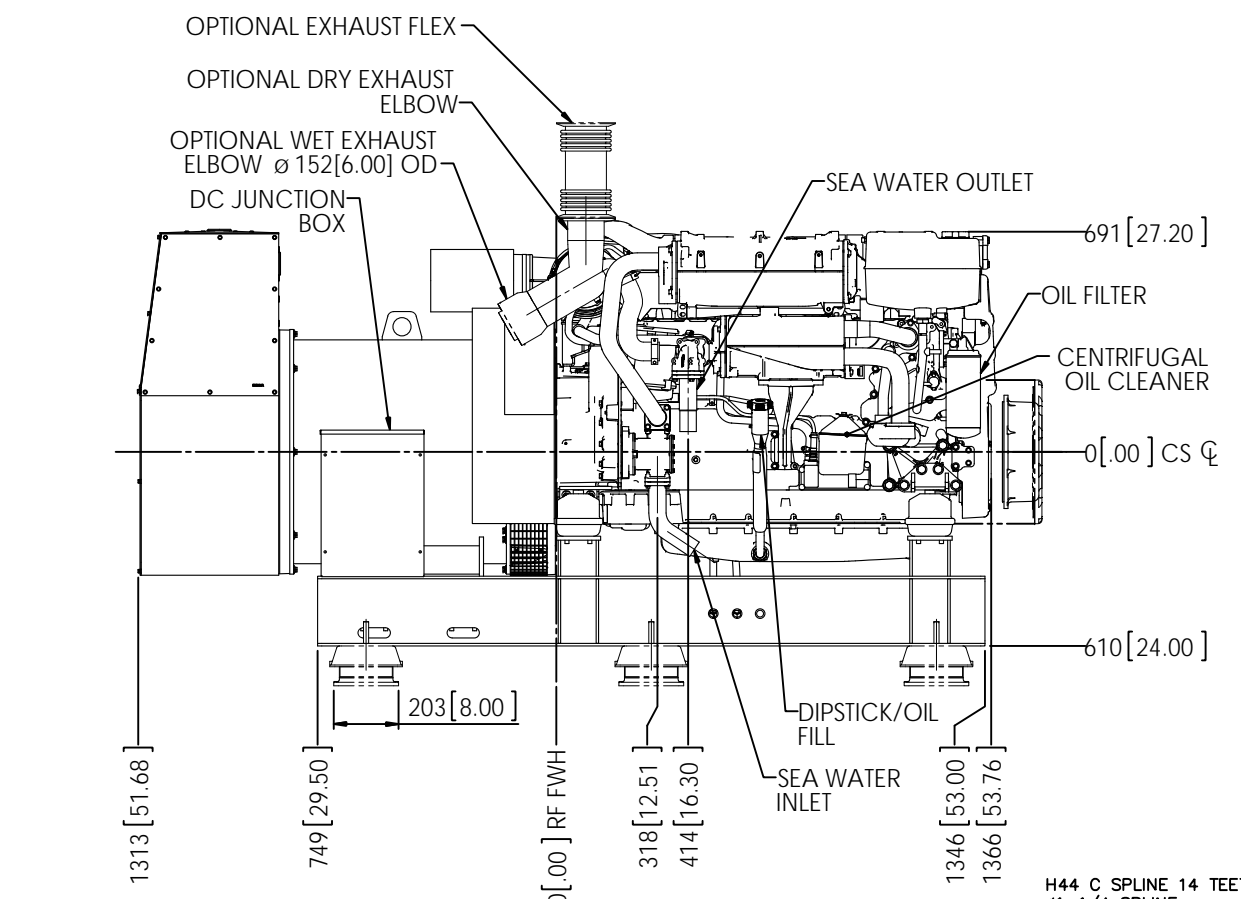

LEFT SIDE

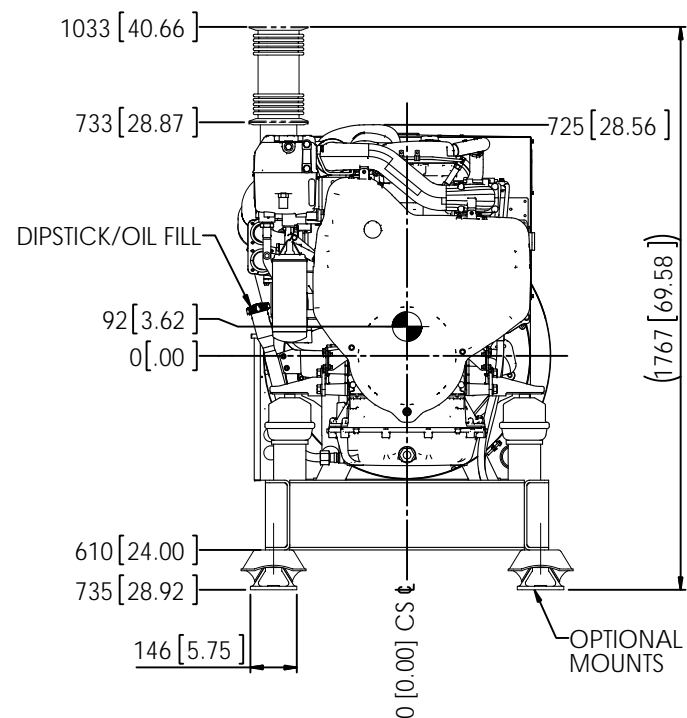

FRONT

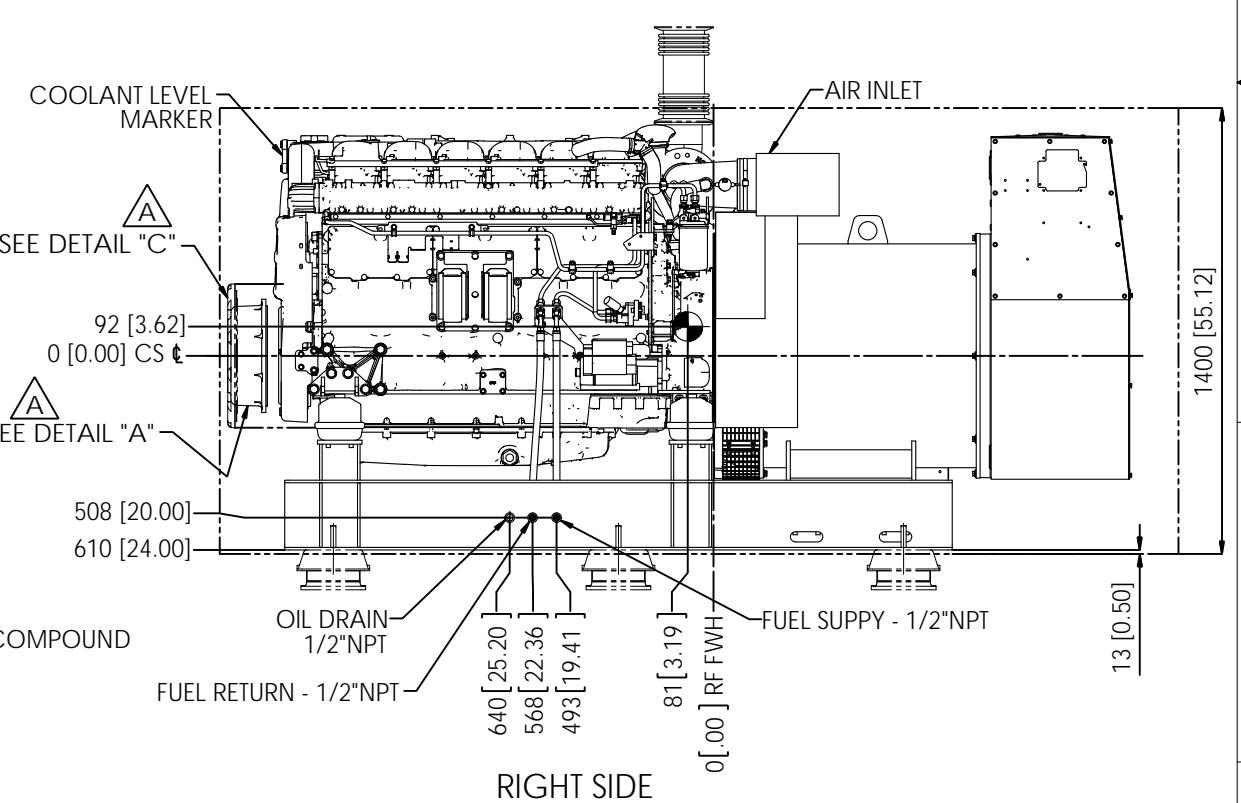

RIGHT SIDE

H44 C SPLINE 14 TEETH 12/24 D.P.
ø1-1/4 SPLINE

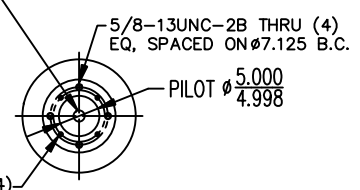

SAE C-PAD
DETAIL A

D SPLINE 13 TEETH 8/16 D.P.
ø1-3/4 SPLINE

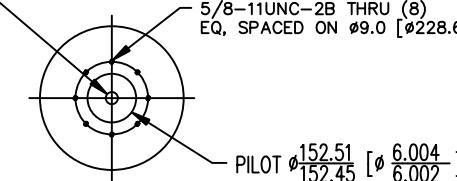

SAE D-PAD
DETAIL C

THE DIMENSIONS ON THIS DRAWING ARE SUBJECT TO CHANGE. PLEASE CONTACT NLI TO BE SURE YOU HAVE THE MOST CURRENT REVISION.

REV	DESCRIPTION	DATE	BY	CHECKED
B	ADDED WEIGHT TABLE. ECN 3530	9/17/2015	MG	TAH
A	ADDED OPTIONAL C-SPLINE AND D-SPLINE PTO DETAILS. ECN 3528	9/16/2015	MG	TAH

REVISIONS			
UNLESS OTHERWISE SPECIFIED:	NAME	DATE	
DRAWN	MG	04/22/15	
CHECKED	TAH	05/07/15	
ENG APPR.			
MFG APPR.			
Q.A.			
COMMENTS:			

NORTHERN LIGHTS		4420 14th AVE. N.W. Seattle, WA 98107 (206) 789-3880 www.northern-lights.com	
TITLE: INSTALLATION DIMENSIONS M1306A32			
SIZE	PART NO.	DWG. NO.	REV
D		D-4854	B
SCALE: 1:12	WEIGHT:	SHEET 1 OF 1	