

MODELS	APPROX. WT. lbs [kg]
M99C13.21 99kW 1800 RPM 60Hz 3 ϕ	2530 [1148]

ITEM	DESCRIPTION
1	EXPANSION TANK
2	COOLANT FILL
3	COOLANT INLET ϕ 1.5 H.B.
4	COOLANT OUTLET ϕ 1.5 H.B.
5	FUEL SUPPLY ϕ 3/8 H.B.
6	FUEL RETURN ϕ 1/4 H.B.
7	CRANKCASE OIL DIPSTICK
8	CRANKCASE OIL FILLER
9	CRANKCASE OIL FILTER
10	ENGINE OIL DRAIN - M18x1.5
11	AIR INLET FILTER
12	OPTIONAL DRY EXHAUST ELBOW - SEE DETAIL
13	CLOSED CRANKCASE VENTILATION SYSTEM
14	ELECTRIC STARTER
15	PRIMARY FUEL FILTER
16	FINAL FUEL FILTER
17	ENGINE CONTROL UNIT
18	OPTIONAL PMG

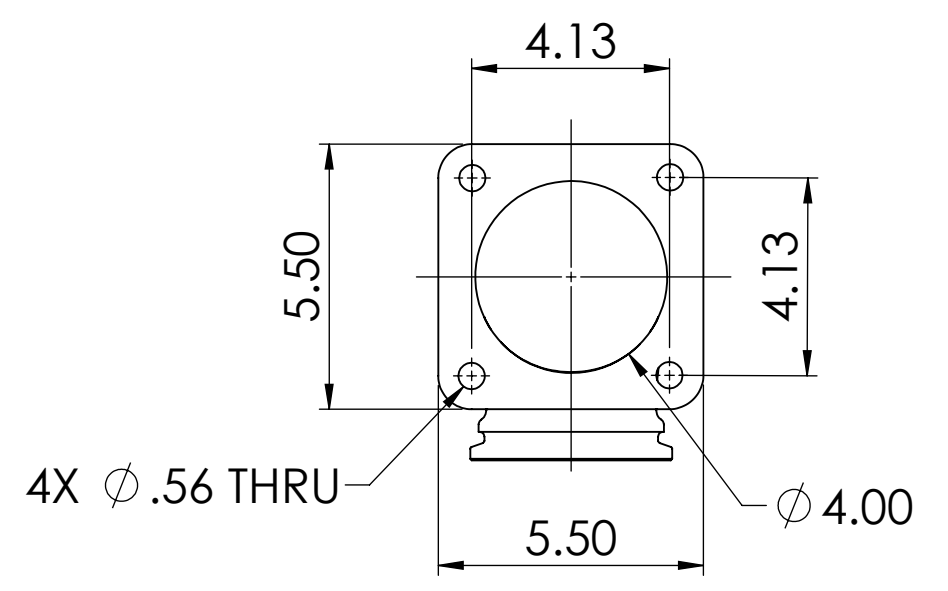

OPTIONAL DRY EXHAUST ELBOW FLANGE DETAIL

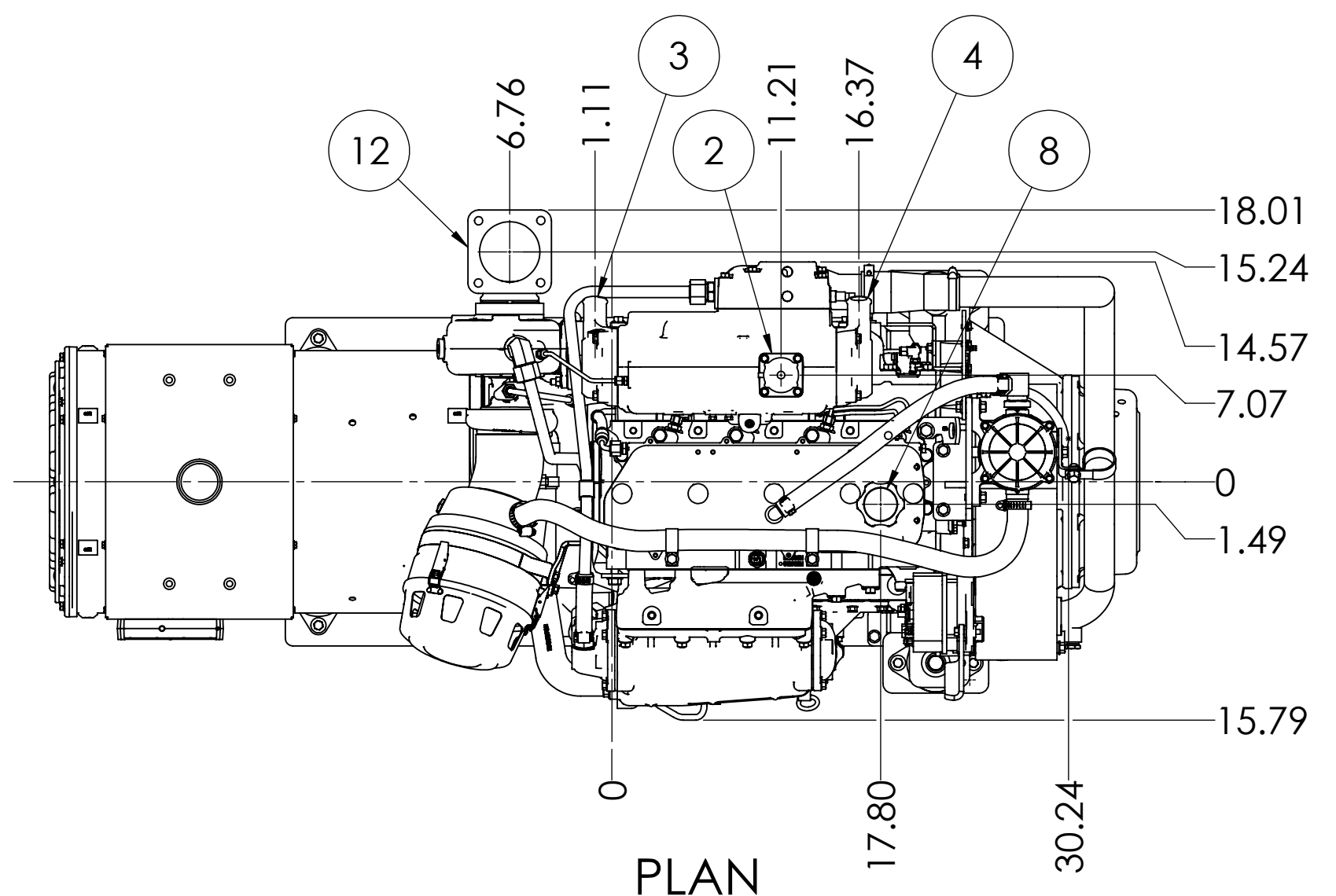
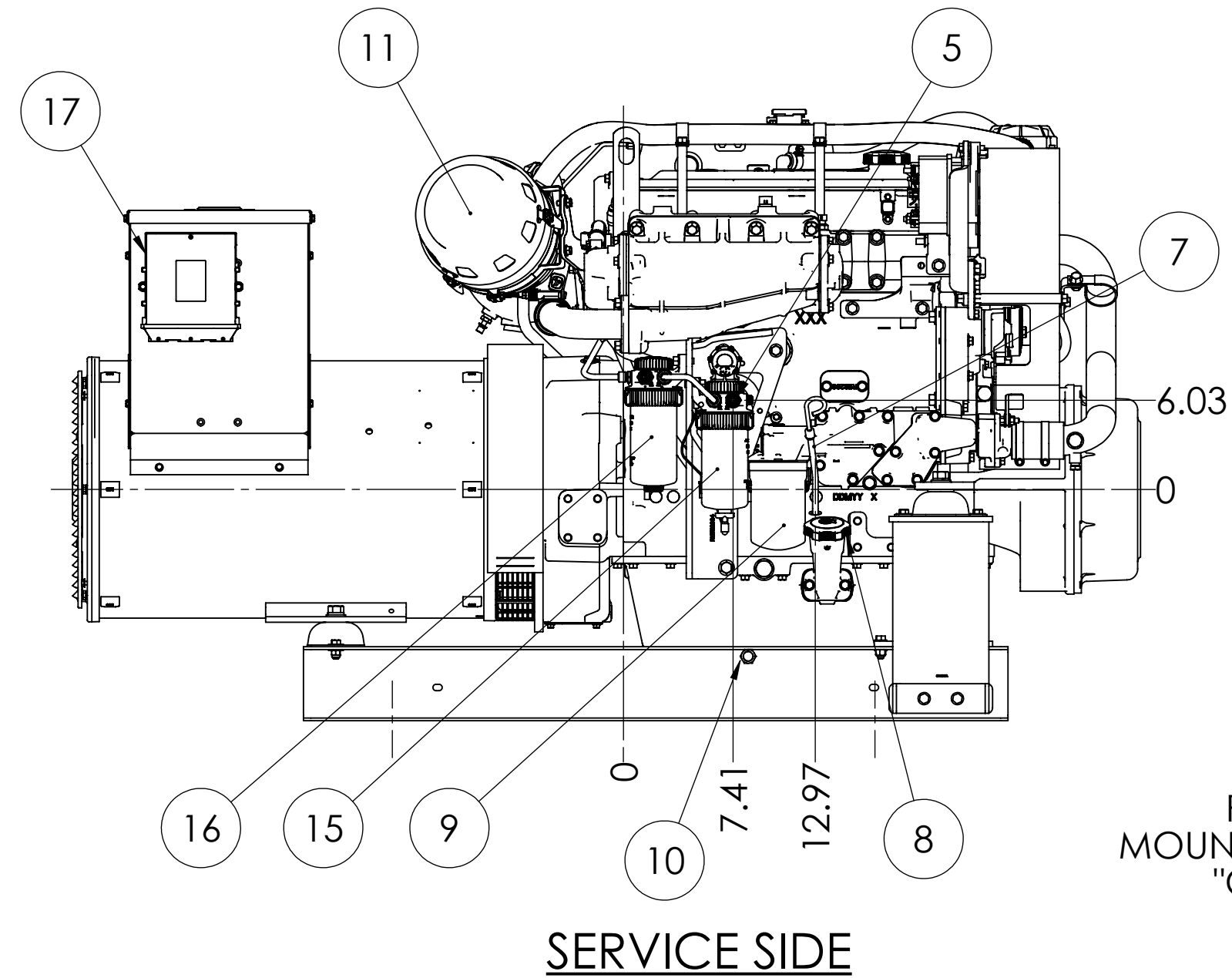

SERVICE SIDE

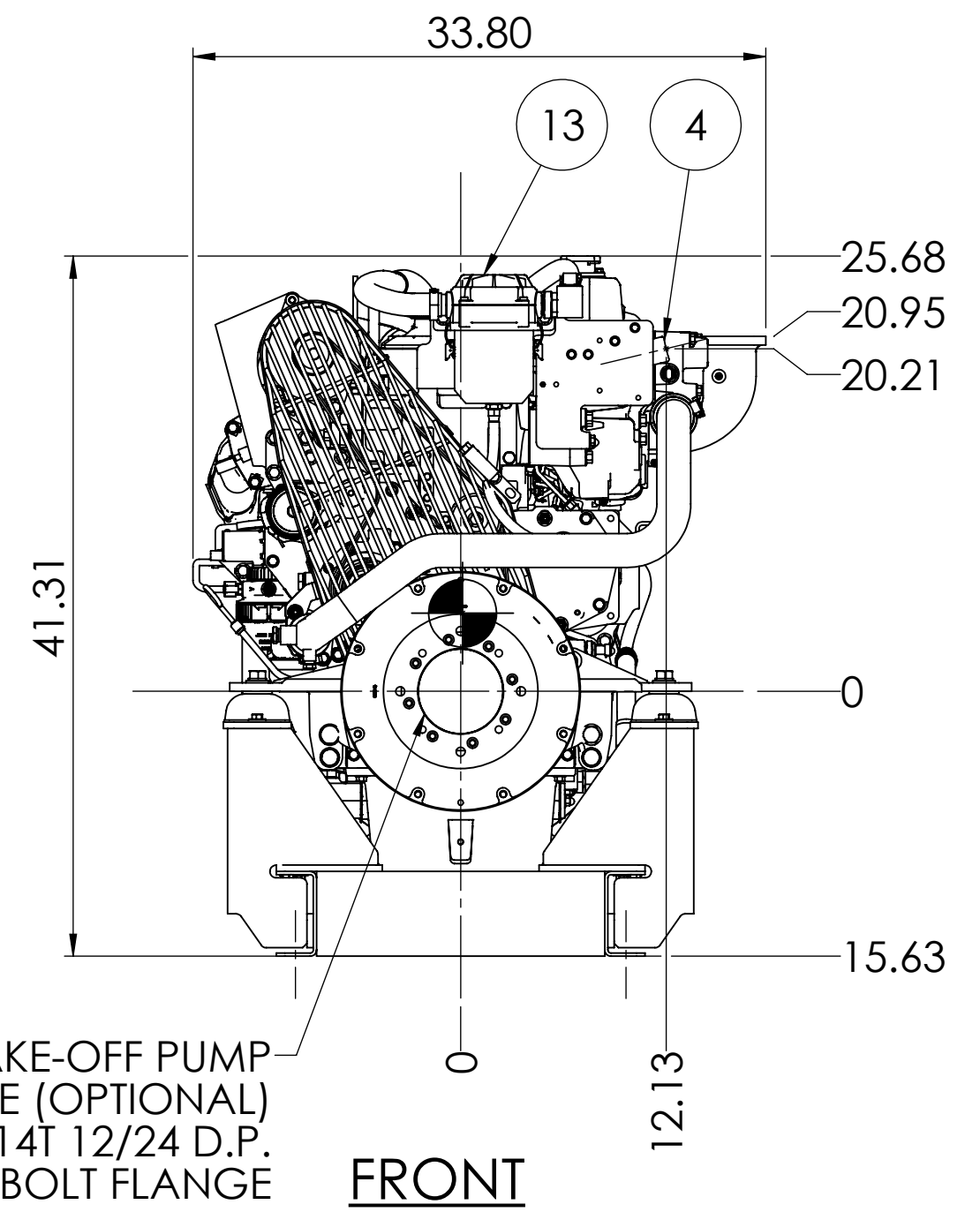

FRONT

POWER TAKE-OFF PUMP MOUNTING FACE (OPTIONAL) "C" SPLINE 14T 12/24 D.P. 2 AND 4 BOLT FLANGE

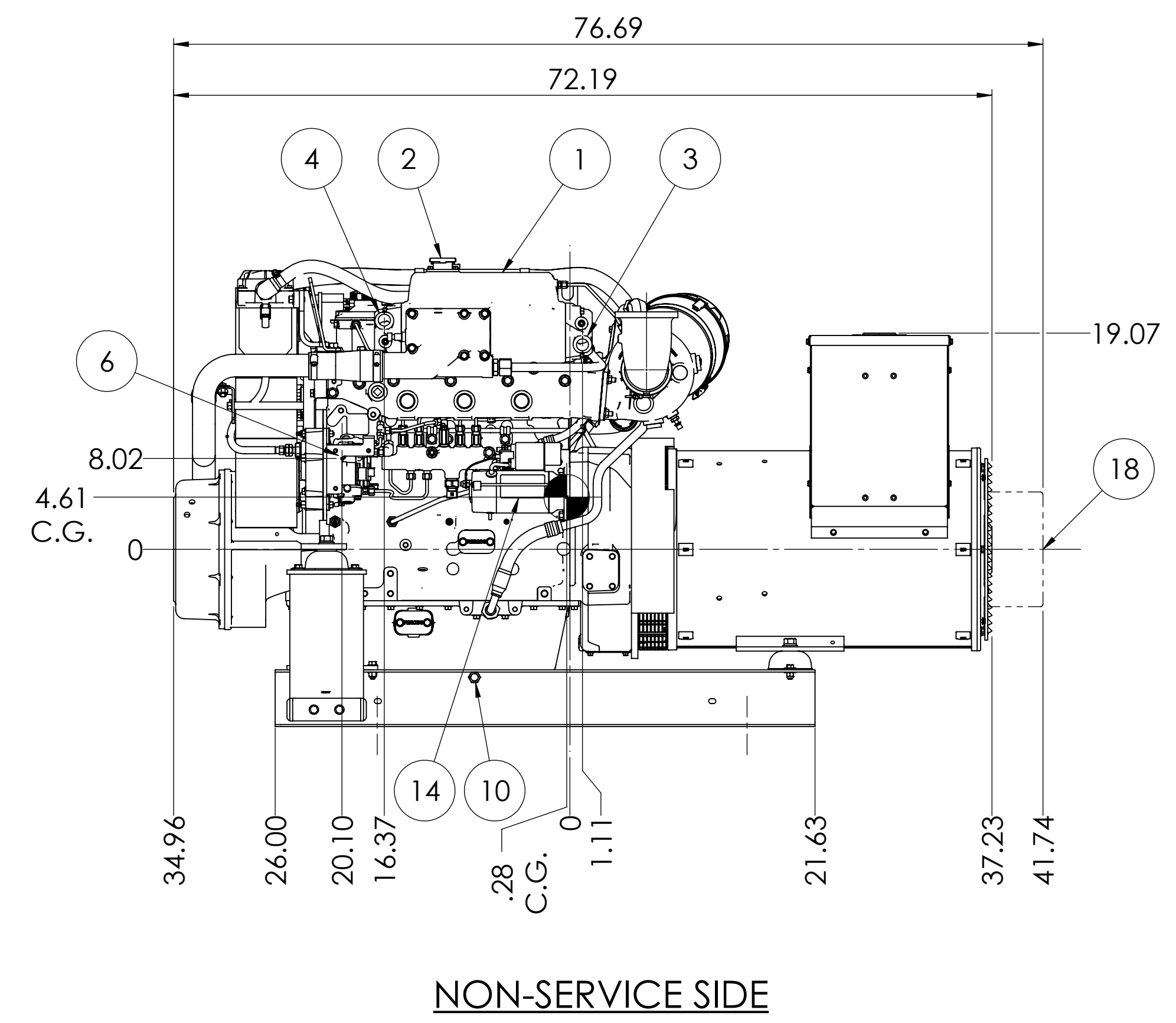

NON-SERVICE SIDE

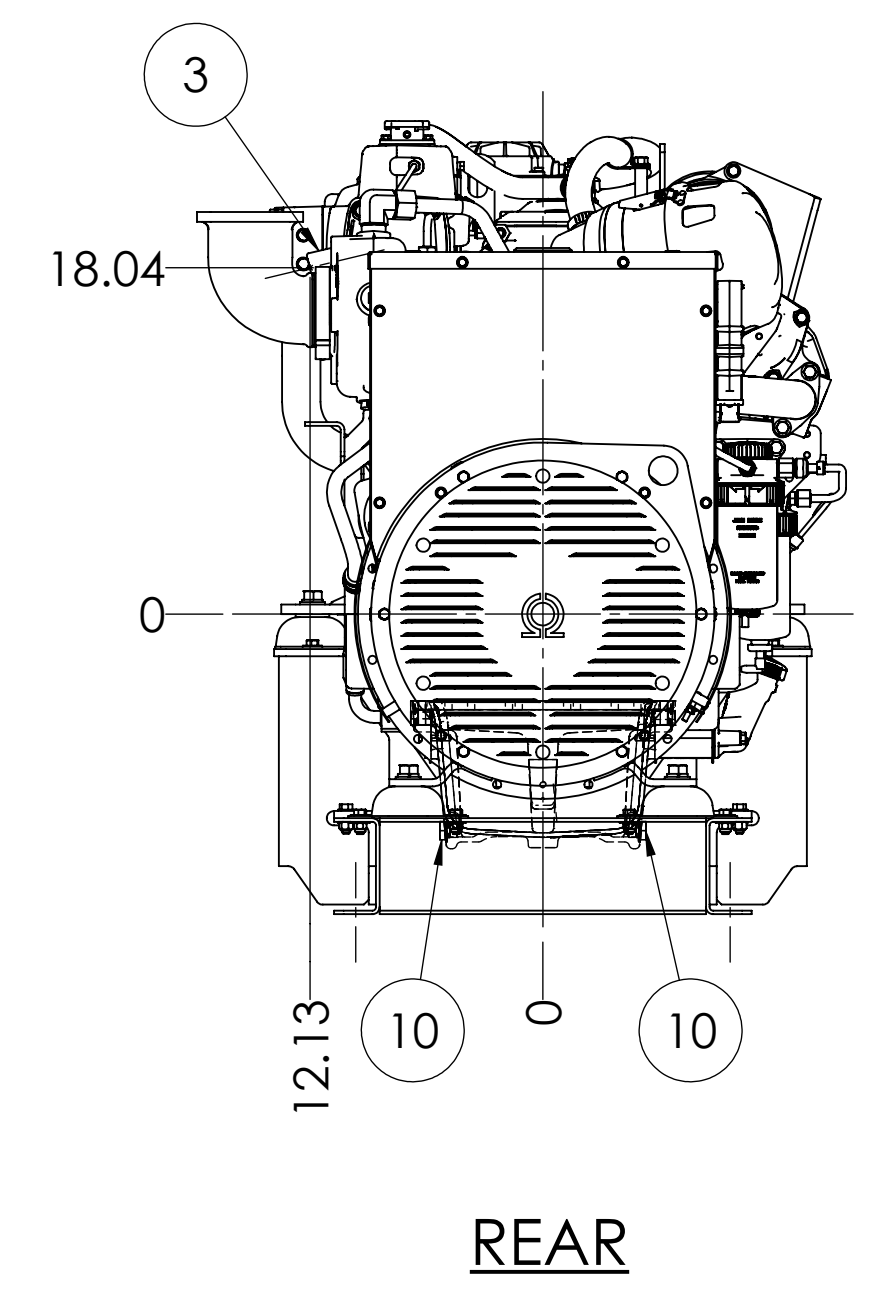

REAR

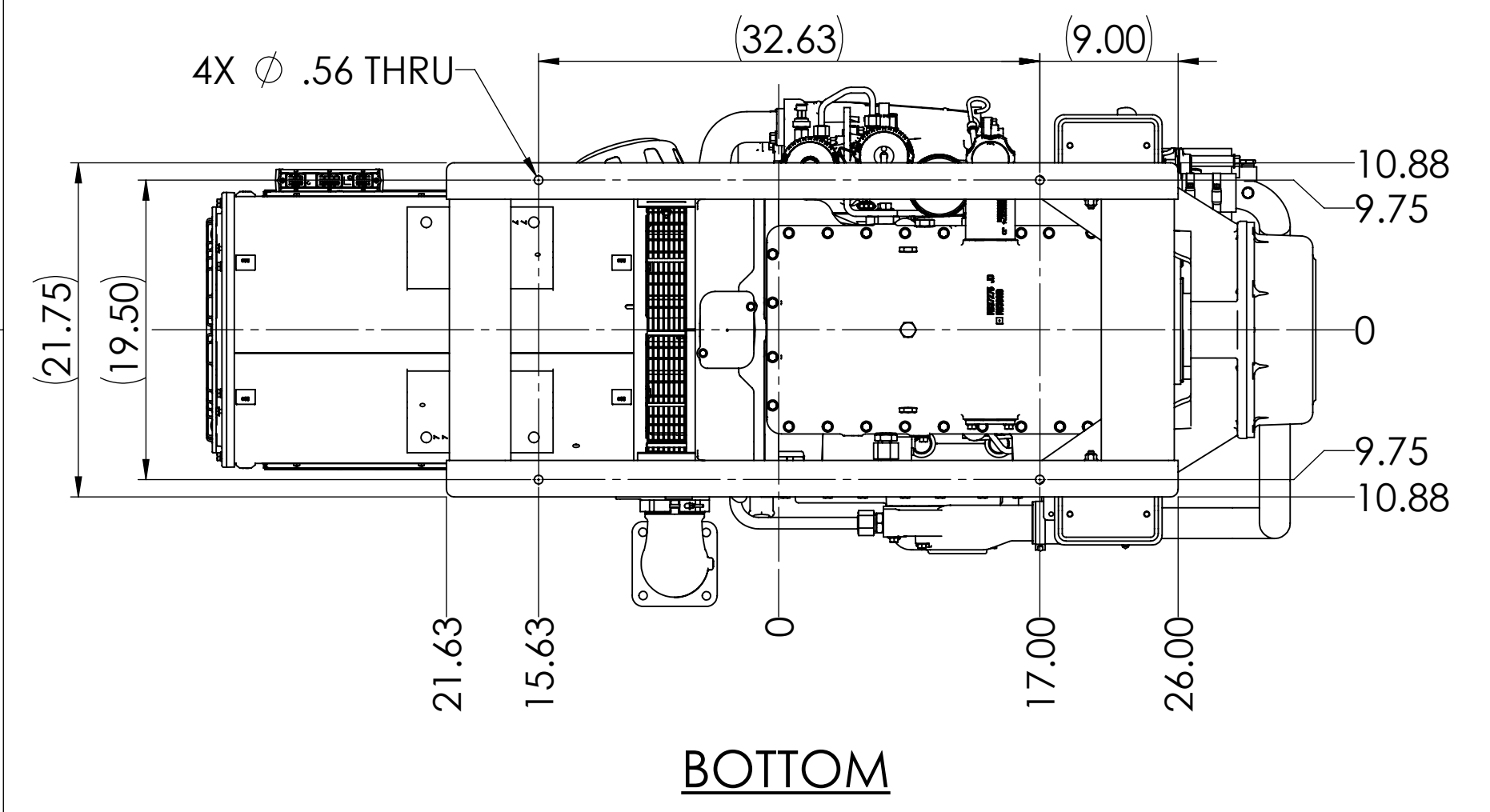

BOTTOM

NOTE: SEE D-4928 FOR INSTALLATION DIMENSIONS OF THE M99C13.21 WITHOUT OPTIONAL PTO.

THE DIMENSIONS ON THIS DRAWING ARE SUBJECT TO CHANGE. PLEASE CONTACT NLI TO BE SURE YOU HAVE THE MOST CURRENT REVISION.

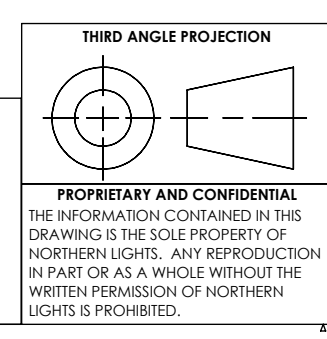

UNLESS OTHERWISE SPECIFIED:		NAME	DATE
DIMENSIONS ARE IN INCHES		MG	03/28/17
TOLERANCES:		CHECKED	TAH
ANGULAR:		ENG APPR.	
RADIUS: 0.5° BEND ± 1.0°		MFG APPR.	
X ± 0.1		Q.A.	
XX ± 0.03		COMMENTS:	
XXX ± 0.005			
INTERPRET GEOMETRIC TOLERANCING PER: ASME Y14.5M			
MATERIAL:			
FINISH:			
DO NOT SCALE			

		4420 14th AVE. N.W. Seattle, WA 98107 (206) 789-3880 www.northern-lights.com	
TITLE: INSTALLATION DIMENSIONS M99C13.21 WITH OPTIONAL PTO			
SIZE	PART NO.	DWG. NO.	REV
D		D-4933	
SCALE: 1:10	WEIGHT: LBS.	SHEET 1 OF 1	

REV D-4933