

P/N	APPLICATION
M1305A22.51 (SHOWN)	200kW@1500RPM 3PH Heat Exchanger Cooled SAE#1/#14 IMO Tier 2
M1305A22.11	200kW@1800RPM 3PH Heat Exchanger Cooled SAE#1/#14 IMO Tier 2
M1305A12.51	185KW@1500RPM 3PH Heat Exchanger Cooled SAE#1/#14 IMO Tier 2

WEIGHT: 2,252 KG [4,965 LB]

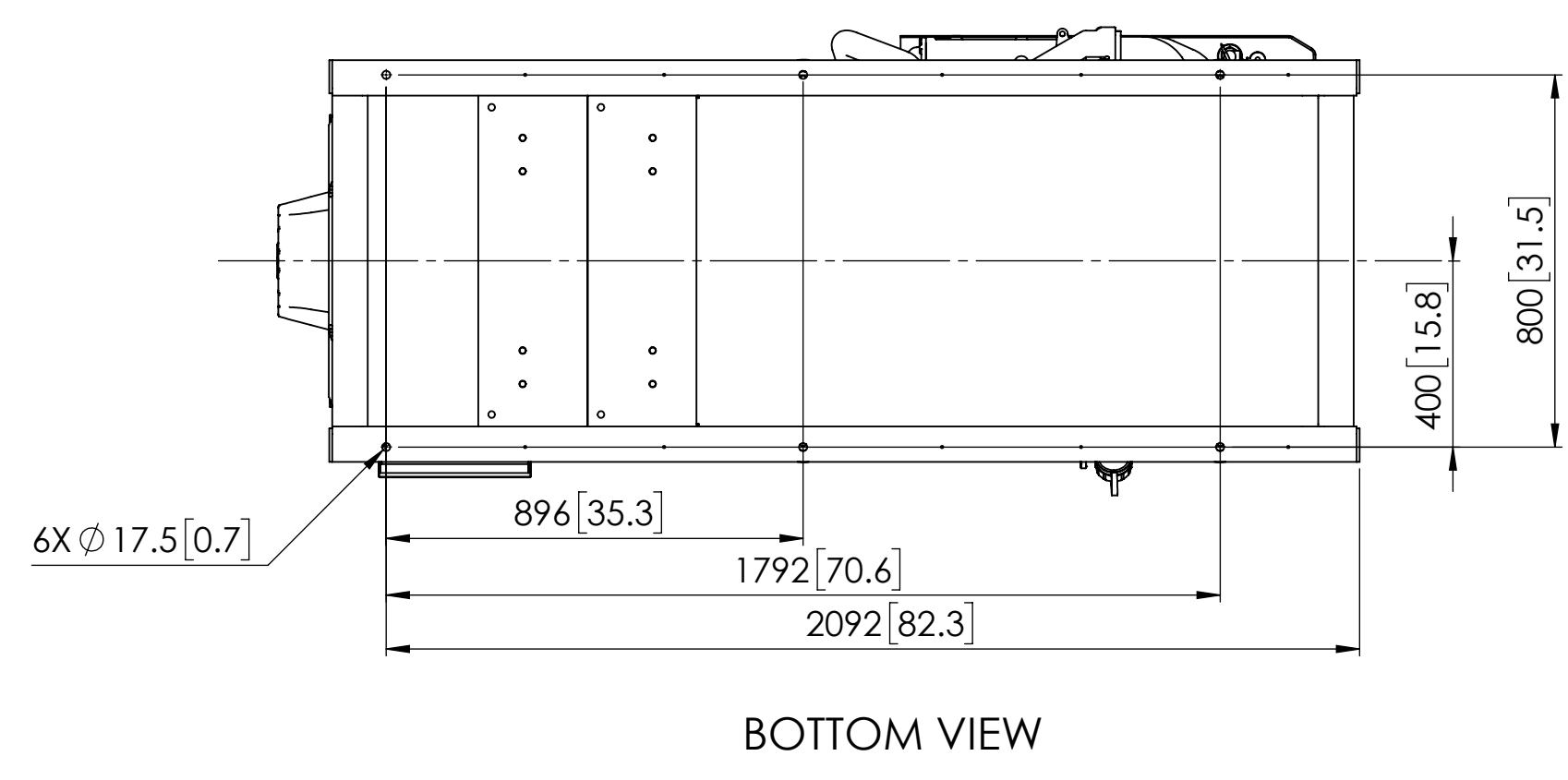

THE DIMENSIONS ON THIS DRAWING ARE SUBJECT TO CHANGE: PLEASE CONTACT NLI TO BE SURE YOU HAVE THE MOST CURRENT REVISION

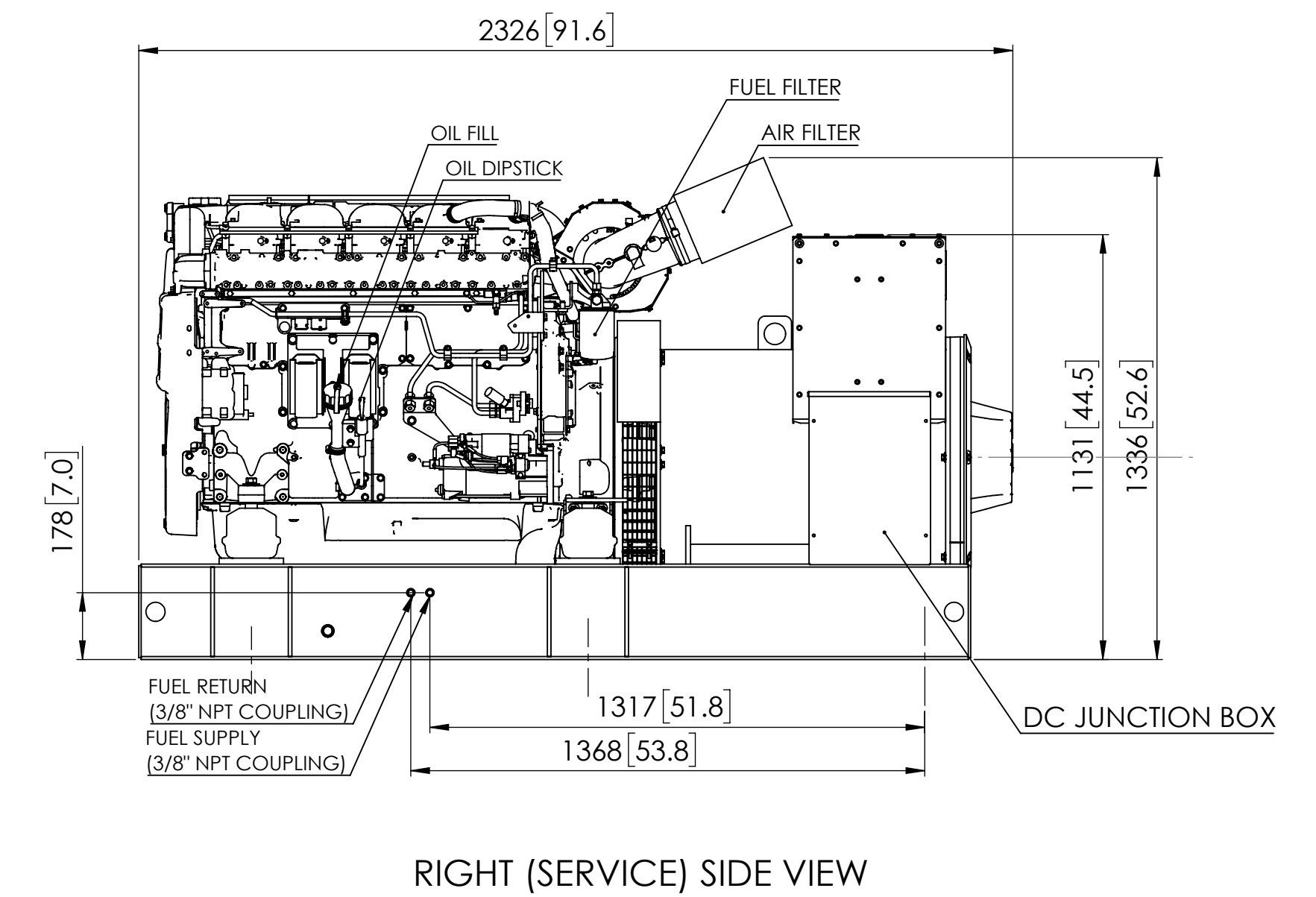
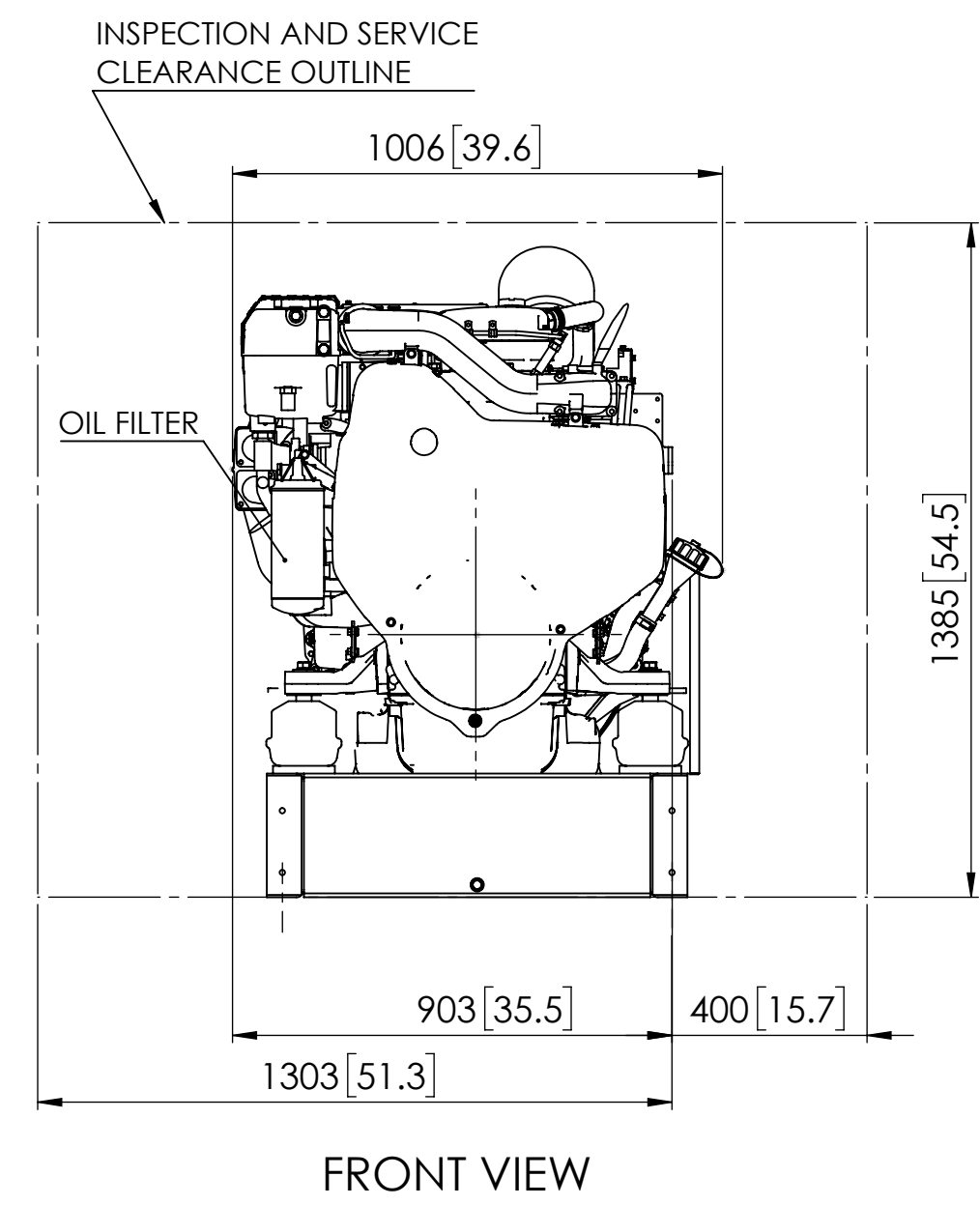
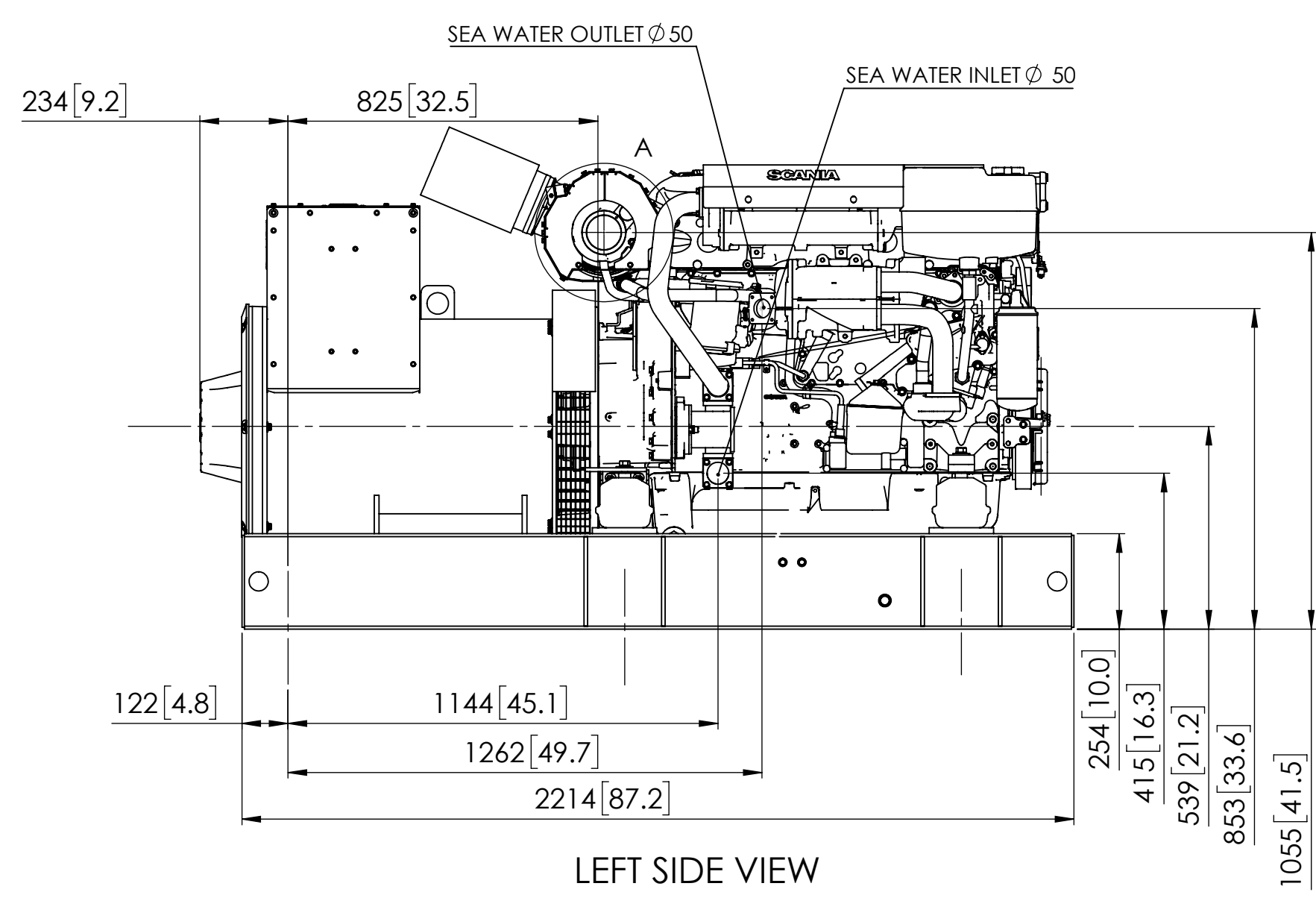
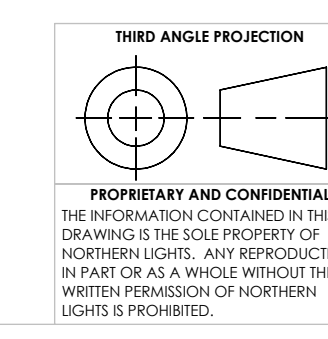

UNLESS OTHERWISE SPECIFIED: DIMENSIONS ARE IN MILLIMETERS TOLERANCES: ANGULAR: ±0.5° HOLE: ±0.1° BEND ± 1.0° X: ± 1.0	NAME: AZB DATE: 12/8/16
INTERPRET GEOMETRIC TOLERANCING PER: ASME Y14.5M	CHECKED: TAH DATE: 12/12/16
MATERIAL:	ENG APPR.:
FINISH:	MFG APPR.:
DO NOT SCALE	Q.A.:
	COMMENTS:

NORTHERN LIGHTS

4420 14th AVE. N.W.
Seattle, WA 98107
(206) 789-3880
www.northern-lights.com

TITLE: INSTALLATION DIMENSIONS
M1305A-2 SERIES (432 GENERATOR END)

SIZE: D	PART NO. SEE P/N TABLE	DWG. NO. D-4986	REV
SCALE: 1:1	WEIGHT:		SHEET 1 OF 1