



OTCW-FX2
for the chilled water FX2 control panel

OPERATOR'S MANUAL

Technicold Marine Systems | www.technicold.com



TECHNICOLD
by **NORTHERN LIGHTS**



Technicold by Northern Lights

1419 W. Newport Center Drive

Deerfield Beach, FL 33442

Tel: (954) 421-1717

Fax: (954) 421-1712

Copyright ©2012, Northern Lights, Inc.
All rights reserved. Northern Lights, Technicold,
the Northern Lights logo, and the Technicold logo are
trademarks of Northern Lights, Inc.

Printed in U.S.A.
PART NO.: OTCW-FX2 4/12



TECHNICOLD
by NORTHERN LIGHTS

OPERATOR'S MANUAL

for OTCW-FX2

*Read this operator's manual thoroughly before starting to operate your equipment.
This manual contains information you will need to run and service your new unit.*

Table of Contents

INTRODUCTION	2
Before You Start.....	2
 OPERATING SCREENS	
Screen Saver	3
Cool Mode.....	3
Heat Mode	3
Automatic Mode	4
Preparing the Fan	4 - 5
 PROGRAM PARAMETERS	5
 PARAMETER DESCRIPTIONS	6
 OPTIONAL CAN BUS CONTROL.....	7
 DRAWINGS.....	8 - 12
 WARRANTY INFORMATION.....	14 - 15

NOTES: All items labeled COMP should be considered Electric Heater applications.
When the Alternate Air Sensor is required the Outside Air Sensor is not available.

Proprietary Information
This publication is the property of Northern Lights, Inc.
It may not be reproduced in whole or in part without the written permission of Northern Lights, Inc.
© Northern Lights, Inc. All right reserved.

Every precaution has been taken in the preparation of this manual to insure its accuracy. However, Technicold by Northern Lights assumes no responsibility for errors and omissions. Neither is any liability assumed for damages resulting from the use of this product and information contained herein.

Litho U.S.A. Publication number OTCW-FX2 4/12

INTRODUCTION

The FX2-AH digital controller allows for easy adjustment of fan speed, operating mode and temperature in a compact, easily readable display. The FX2-AH digital control is designed to operate with marine chilled water systems.

Features include:

- ① Four position menu navigation switch featuring a joystick style interface with push on / push off control.
- ① Built in room temperature sensor.
- ① The display is compatible with Vimar and Gewiss frames.
- ① Visual symbols enable the viewer to see the operating status at a glance.
- ① Easily programmed for customized operation.
- ① Both automatic and manual six level fan speed adjustment.
- ① Universal 115/230 VAC 50/60 Hz power supply.

Optional Features include:

- ① Outside air temperature sensor.
- ① Alternate air sensor..

BEFORE YOU START

1. Applying power:

When power is first applied, the display will show the software revision, and then return to the last state the unit was in when power was removed.

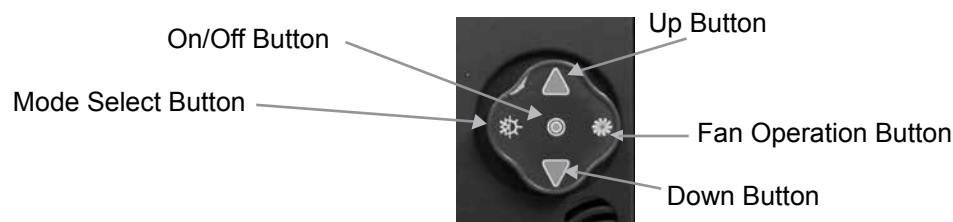

2. Joystick operation:

The four position joystick may be tapped up, down, right, left or in the center to make changes to the operation of the control. Gently tap this switch to operate it. Excessive force will damage the switch.

3. Operating states:

The display operates in 2 operational states. In the OFF state, the temperature is displayed and only fan operation is available. In the ON state, the display shows the temperature set point, room temperature, fan, and valve status. Switch between these states by pressing and releasing the On/Off button.

OPERATING SCREENS

Screen Saver



Screen Saver

In screen saver, the display will appear dim and the information will scroll across the screen. Status symbols appear as needed and operation continues in the mode selected. To exit this mode, just tap any button.

Cool Mode



Cool Mode

To select cooling only, tap the mode select button to scroll through the symbols in the top left of the display until the cool symbol appears. Set the desired room temperature by tapping the up or down button. The system will provide cooling as necessary. The valve symbol will appear when system is cooling.

Heat Mode



Heat Mode

To select heating only, tap the mode select button to scroll through the symbols in the top left of the display until the heat symbol appears. Set the desired room temperature by tapping the up or down button. The system will provide heating as necessary. The valve or electric heat symbol will appear when the system is heating.

OPERATING SCREENS

Automatic Mode



Automatic Mode

To select automatic mode, tap the mode select button to scroll through the symbols in the top left of the display until the automatic mode symbol appears. In this mode, the system will automatically maintain room temperature. Set the desired room temperature by tapping the up or down joystick button. When the system is operating, the appropriate symbol will appear in the lower left corner.

Manual Fan Low



Fan Speed Indicator Animated Symbol

Manual Fan High



M=Manual Fan Fan Speed Indicator Animated Symbol

Operating the fan:

Fan speed may be controlled automatically by room temperature or manually. Tap the joystick fan button to cycle through fan speeds and automatic operation. Manually selected fan speed is indicated with the M showing before the speed indicator. When the fan is automatically controlled, the M is not present. The fan may be controlled in the cool, heat, automatic modes as well as in the off state to circulate room air.

Manual fan speed operation is not available when the water valve is not open if the cycle fan option is set. Turn the unit off in this case and then manual fan operation may be used.



Outside Air Temperature

If the optional outside air temperature sensor is installed, the temperature set point in the upper right of the display will alternate with OAT showing outside air temperature.

OPERATING SCREENS

**Viewing System Status**

In the ON state, press and hold the Mode select button for two seconds. The display will indicate AC line voltage, System current, AC Line frequency, and loop water temperature. *If the loop water sensor is not installed or fails, no reading will appear. In this case, electric heat will not be available and the system will open the valve when necessary regardless of loop temperature.*

Air Sensor Trouble

If the air sensor fails, AIR SENSOR TROUBLE will appear on the display. The air sensor should be checked by a qualified service person.

PROGRAM PARAMETERS

There are fifteen programmable parameters with their factory defaults described in this section. The table below defines the parameter descriptions along with the permitted values and default settings.

To enter the program mode first put the unit in the off state. Next press the following sequence of buttons: **Mode, Up, Down, Mode**. Use the fan button to advance to the next parameter and the mode button to go back to the last parameter. Use the up and down buttons to change the parameters value. Exit the program mode when finished by pressing and releasing the On/Off button or wait 60 seconds for the display to exit.

Description	Default	Value
Cycle fan	Continuous	Cycle or Continuous
Reverse fan in heat	Reverse	Reverse or Normal
System units	°F	°F or °C
Display brightness	15	4=Minimum 15=Maximum
Screen saver brightness	4	- and 1-8
Temperature calibration	0	Ambient +/- 10°F
Alternate air enabled	Alternate air enabled	Alternate air enabled or Outside air enabled
Electric heat	No electric heat	Electric heat or No electric heat
Normal valve operation	Normal valve operation	Normal valve operation or Valve override
Fan speed 1	30	30-90
Fan speed 2	35	30-90
Fan speed 3	40	30-90
Fan speed 4	45	30-90
Fan speed 5	55	30-90
Fan speed 6	85	30-90
Reset parameters	No	No or Yes

PARAMETER DESCRIPTION

- o Cycled fan: When set for cycled, the fan will operate on demand. When set for continuous, the fan will always run unless you turn the system off.
- o Reverse fan in heat: Fan speed will increase as the room temperature rises if this parameter is set for reverse. If set for normal, fan speed will decrease as room temperature rises. This parameter only works in heat mode and the fan must be set for automatic operation.
- o System units: Degrees Fahrenheit (°F) or degrees Celsius (°C) can be selected
- o Display brightness: Display brightness can be set from 4 to 15 to suit room lighting. Brightness will change as the number is changed.
- o Screen saver brightness: If set for (-) then a single bar (-) will blink sequentially in the four corners of the display. Number values from 1 to 8 can be set to suit room brightness and the unit will operated as described in the screen saver section.
- o Temperature calibration: This parameter allows the user to calibrate the room air temperature sensor. The room temperature will be displayed and can be adjusted +/-10 °F or +/-5°C
- o Alt air enabled: When set for alt air enabled, the alt air jack can be used with an optional air sensor to replace the display mounted air sensor. When set for outside air enabled, an optional sensor may be installed to monitor out side air temperature. This will appear as OAT on the display.
- o Electric heat/ No electric heat: Set this parameter only if the system is equipped with an electric heater. The electric heater is connected to the compressor L1 and compressor L2 terminals. Heater current must not exceed 30 Amps.
- o Normal water valve operation: This feature allows service personnel to force the water valve open to facilitate bleeding air from the system. Selecting override will force the water valve open for four hours. This operation can be reset by turning the system on with the On/Off button.
- o Fan speed 1-6: These parameters are used to optimize fan performance and should be changed only by qualified service personnel.
- o Reset parameters: To reset all parameters to factory defaults, select YES and then exit the program mode by pressing the joystick center button. The display will show EEPROM RESET then show the room temperature in the off mode.

SPECIFICATIONS

Set point range	55°F to 85°F 12.7°C to 29.4°C
Ambient temperature range displayed.....	5°F to 150°F
Sensor accuracy.....	2°F at 77°F
Low voltage limit 115 VAC units	75VAC
Low voltage limit 230 VAC units	175VAC
Line voltage limit.....	250VAC
Frequency.....	50 or 60 Hz
Fan output MAX.....	6 Amps
Valve output MAX.....	10 Amps
Heater output (connected to compressor L1 and L2).....	30 Amps Maximum
Minimum operating temperature.....	0°F
Maximum operating temperature.....	180°F
Maximum RH conditions 99%	Non condensing
Maximum length of the display cable	75 Feet
Maximum length of the Outside air sensor cable	50 Feet

OPTIONAL CAN BUS CONTROL

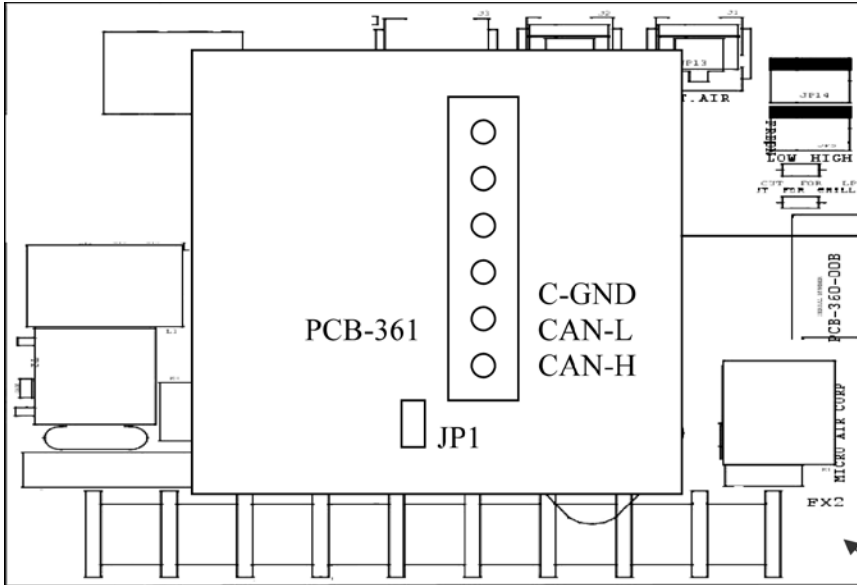

FX2
(PCB-360)

CAN Bus

When the optional CAN bus controller is used, connect the C-GND, CAN-L and CAN-H wires on the bus to the appropriate connection. CAN bus wire system limit is 500 feet and must have a terminator (JP1) on the first (usually the PC) and the last connection in the system only.

Power supplies designed for use with CAN bus systems use power supply board (PCB-360) specific to that application that allow CAN bus. Be sure you have the correct supply before attempting CAN operation.

OPTIONAL FX-MAXX CONTROL WITH UV LAMP

CHILLED WATER APPLICATION

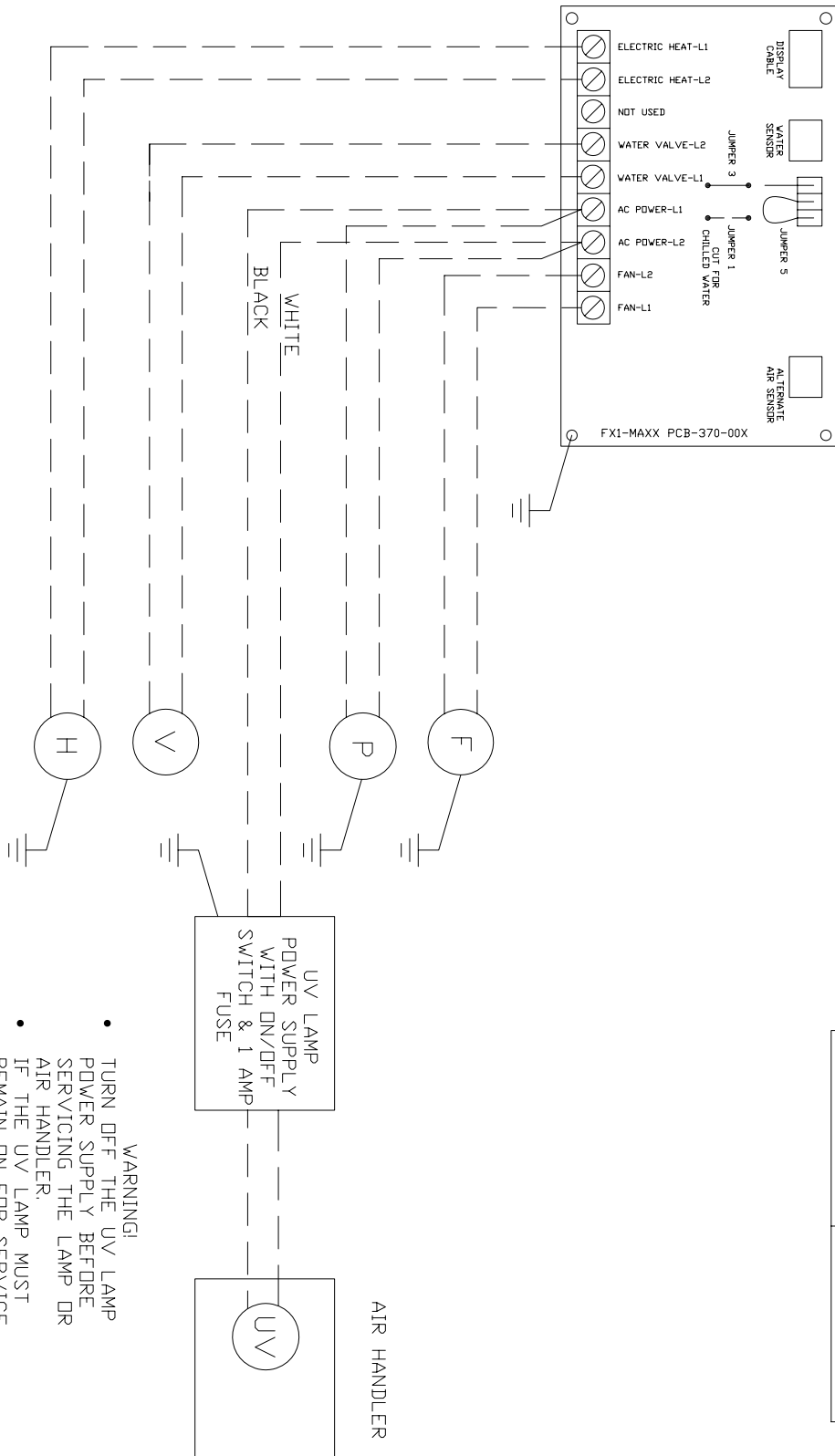

LEGEND	
NOMENCLATURE	DESCRIPTION
F	FAN
P	POWER SUPPLY
UV	UV LAMP
V	WATER VALVE
H	ELECTRIC HEATER

- WARNING!**
- TURN OFF THE UV LAMP POWER SUPPLY BEFORE SERVICING THE LAMP OR AIR HANDLER.
 - IF THE UV LAMP MUST REMAIN ON FOR SERVICE USE APPROPRIATE EYE AND SKIN PROTECTION.
 - TURN OFF UV LAMP POWER SUPPLY BEFORE REMOVING AND CLEANING AIR FILTER. USE ONLY THE AIR FILTER SUPPLIED WITH THE UV LAMP APPLICATION.

JUMPER LOCATIONS & CONFIGURATIONS FOR FX-2

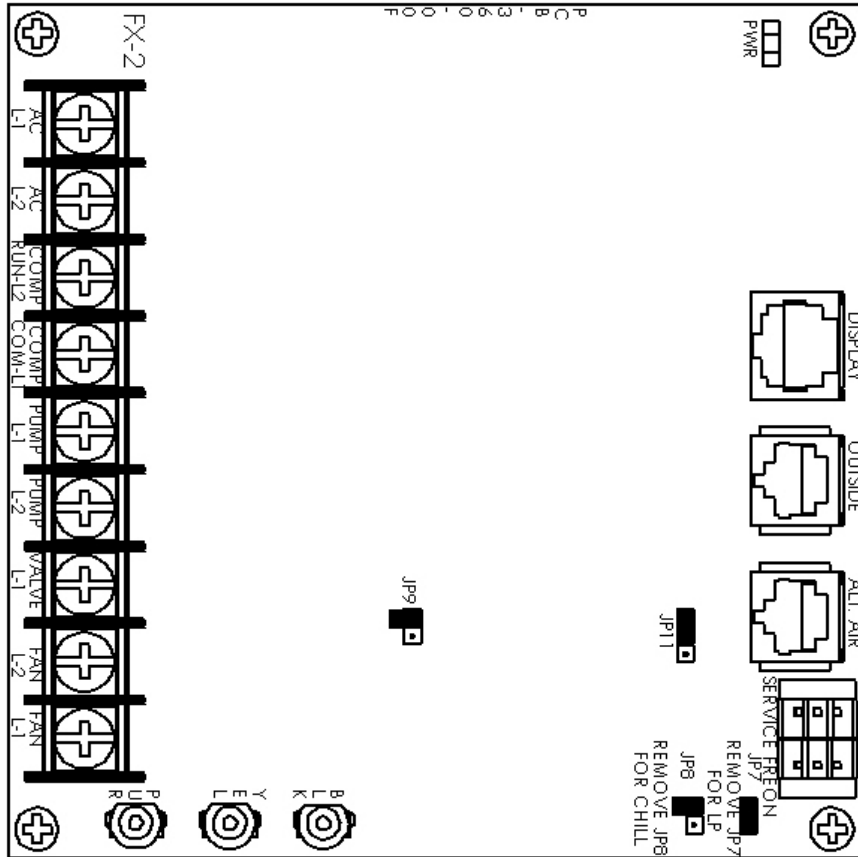

"OLED" jumper configuration:
 JP9 is not installed
 Pins 1 and 2 of JP11 are shorted

FX-2

FX 2 CONTROL WITH UV LAMP FIELD WIRING

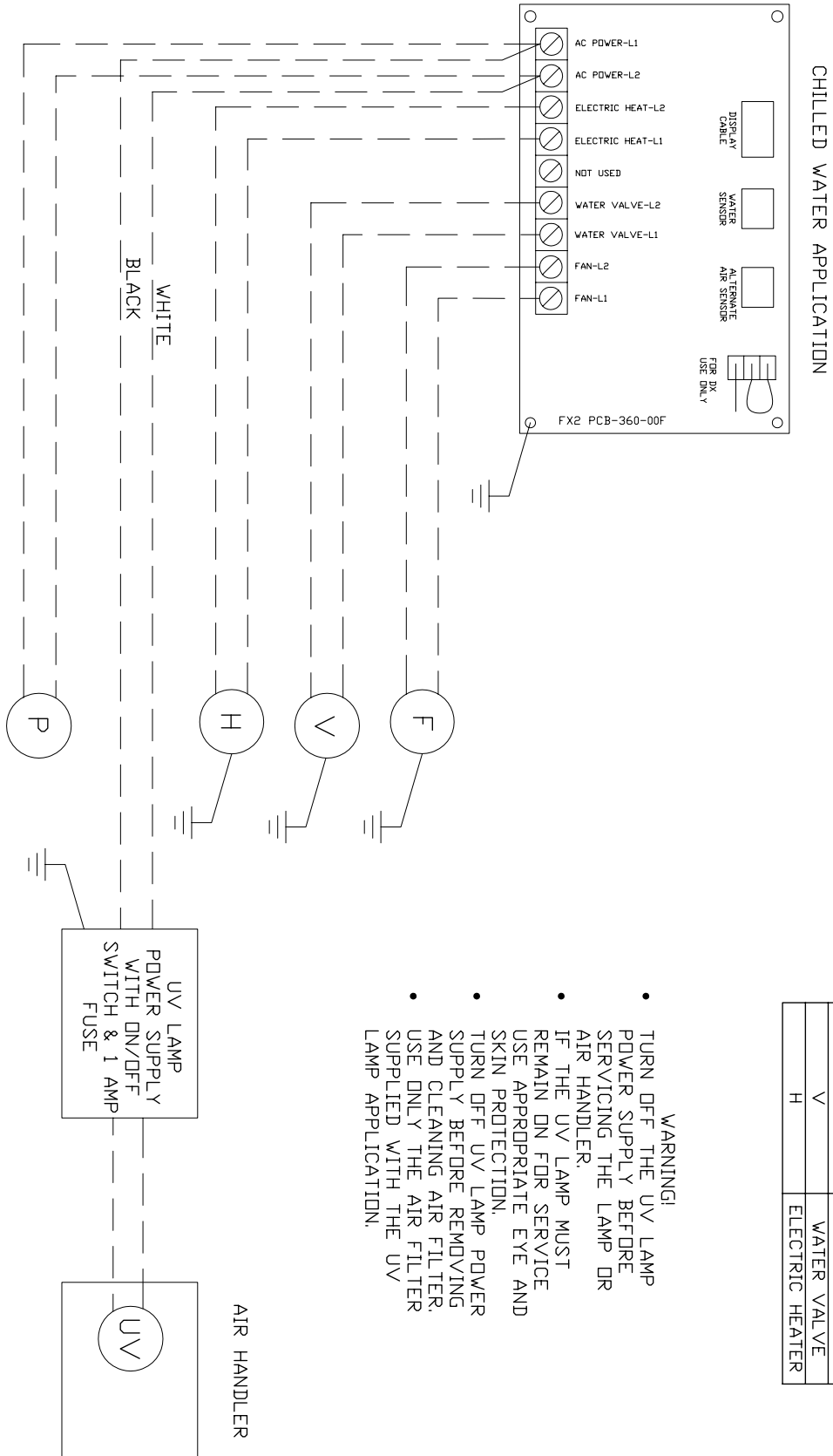

CHILLED WATER APPLICATION

- AC POWER-L1
- AC POWER-L2
- ELECTRIC HEAT-L2
- ELECTRIC HEAT-L1
- NDT USED
- WATER VALVE-L2
- WATER VALVE-L1
- FAN-L2
- FAN-L1

FX2 PCB-360-00F

- DISPLAY CABLE
- WATER SENSOR
- ALTERNATE AIR SENSOR
- FDR DRY USE ONLY

LEGEND

NOMENCLATURE	DESCRIPTION
F	FAN
P	POWER SUPPLY
UV	UV LAMP
V	WATER VALVE
H	ELECTRIC HEATER

WARNING!

- TURN OFF THE UV LAMP POWER SUPPLY BEFORE SERVICING THE LAMP OR AIR HANDLER.
- IF THE UV LAMP MUST REMAIN ON FOR SERVICE USE APPROPRIATE EYE AND SKIN PROTECTION.
- TURN OFF UV LAMP POWER SUPPLY BEFORE REMOVING AND CLEANING AIR FILTER, USE ONLY THE AIR FILTER SUPPLIED WITH THE UV LAMP APPLICATION.

DRAWING SHOWN WITH OPTIONAL CHILL-CHASER ELECTRIC HEAT AND UV LAMP WITH FUSED POWER SUPPLY.

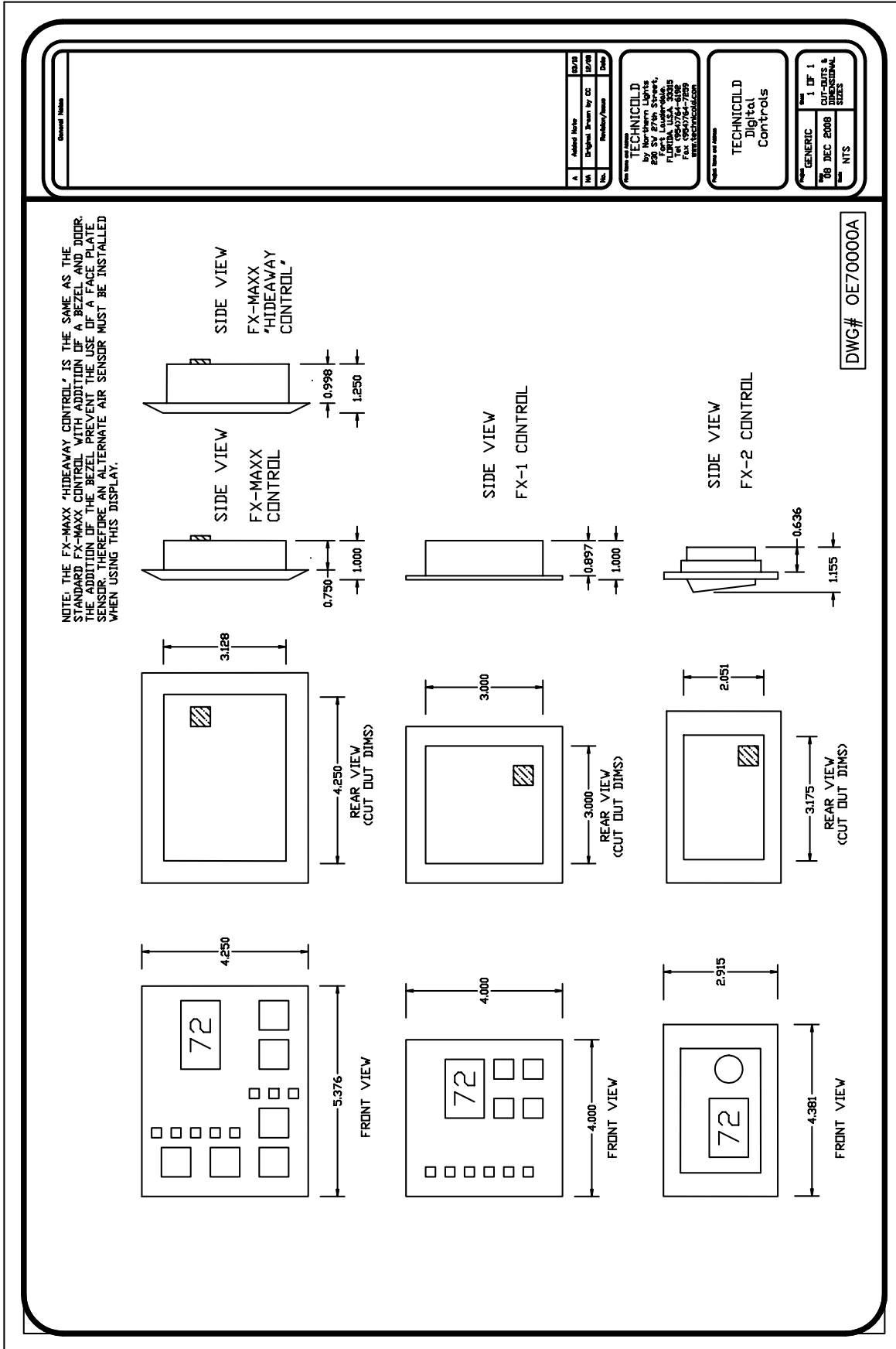

INSTALLATION OVERVIEW

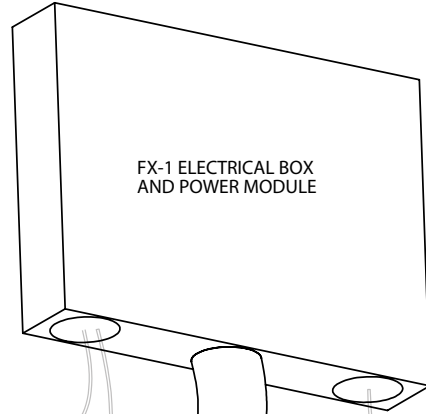
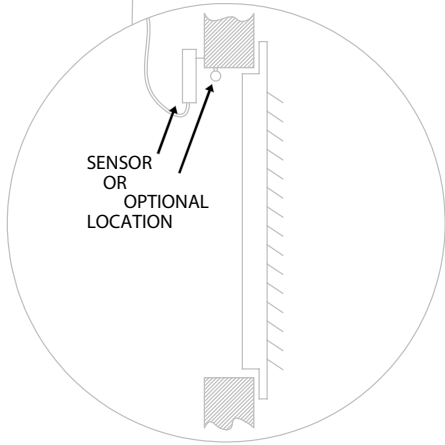
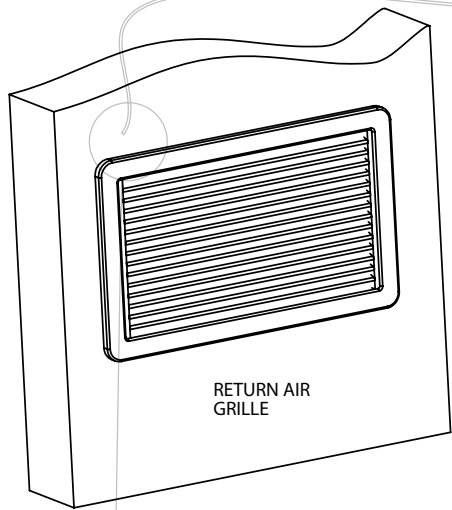

8 CONDUCTOR SHIELDED DISPLAY CABLE

AC WIRE HARNESS

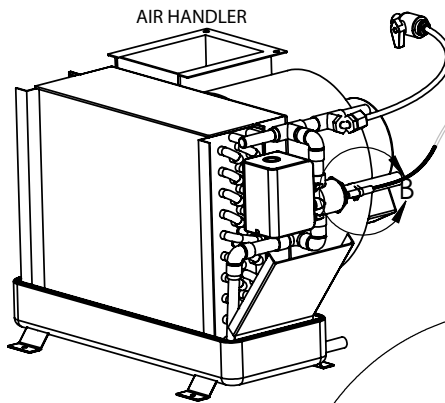

6 CONDUCTOR SHIELDED SENSOR CABLE

WATER INLET SENSOR: INSULATE AFTER ATTACHING

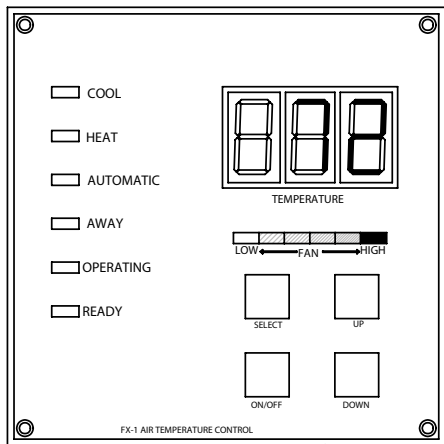
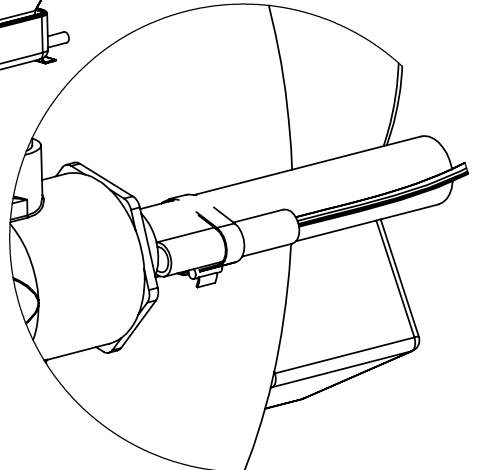

WARRANTY INFORMATION

The Limited Warranty applies to the following product lines: TECHNICOLD Air Conditioning and Refrigeration Products
Technicold manufacturer NORTHERN LIGHTS, INC. (herein "NLI") extends to the purchaser and user (herein "Owner") of the product the following limited warranty (herein "Warranty"). Please read it carefully.

Technicold Air Conditioning and Refrigeration Products

Warranty Period

Product	12 Months
Parts and Labor	12 Months
Parts	24 Months

NLI'S WARRANTY AND RESPONSIBILITIES

Subject to the terms and conditions set out below, NLI warrants the product and its factory installed parts to be free from defects in material and workmanship under normal use and service.

If the product is purchased for and used primarily in a commercial endeavor, the Warranty period shall extend from the date of delivery to the original end user for a period of twelve (12) months with no limit on hours of use. If the product is purchased for and used primarily in personal, family or household use, the warranty period shall extend from the date of delivery to the original end user for a period of twelve (12) months with no limit on hours of use. Original parts shall be warranted for a period of twenty-four (24) months from date of delivery.

The obligation of this Warranty shall be limited to repairing or replacing any part of the product which NLI agrees is defective in materials or workmanship under normal use and service during the warranty period. If during the warranty period the product or any of its parts are found to be defective because of workmanship or materials, it will be repaired or replaced without charge if the Owner prepays the transportation charges and returns the item to NLI's authorized warranty dealer. To find the location of the nearest NLI authorized warranty dealer, contact NLI at the address, e-mail address, or telephone or fax numbers in this publication.

Upon request by the Owner and agreement by NLI, repair of product or replacement of parts under this Warranty may be completed at a place other than at an NLI authorized warranty dealer. See "Owner's Responsibilities".

NLI'S WARRANTY AND RESPONSIBILITIES

Within thirty (30) days of purchase, Owner or authorized agent of Owner must complete, sign and deliver to NLI the Warranty Registration Card in order to validate this warranty. Owner must break in unit as described in the "Operating Procedures" section of the Operator's Manual.

At the time of presentation of product for service under this Warranty, the Owner or authorized agent must present evidence of the date of original purchase of the product.

If pre-approved repair of product or replacement of parts under this Warranty is completed at a place other than an NLI authorized warranty dealer, Owner shall pay NLI's or its authorized dealer's reasonable travel expenses.

Owner shall pay costs of any labor required to remove and reinstall the product and/or parts thereof, any premium for overtime labor requested by the Owner and costs for transporting the product and/or parts thereof to and from the place where warranty work is performed.

WARRANTY LIMITATIONS

This warranty will not apply to equipment put into service more than twenty-four (24) months from date of shipment from factory, and will not apply in any country with which trade is restricted or banned by the U.S. Department of State, at or after the time of sale or claim.

If the product is used primarily in a commercial endeavor, neither NLI nor any company affiliated with NLI will be liable for general damages, including bodily injuries, except as set forth above, or for incidental consequential damages, including, but not limited to, loss of use, loss of profits, loss of production, expense of substitute equipment or other commercial loss or for damage to property in which equipment is installed. The same limitations shall apply to a product used for personal purposes with respect to all non-personal injuries, general, incidental and consequential damages.

Some countries or states do not fully allow the above exclusions or limitations of general, incidental or consequential damages, so the above exclusions or limitations may not apply to you.

This Warranty extends only to the original parts, accessories and products.

This Warranty is transferable to a new Owner during the warranty period. No transfer forms or fees are required.

This Warranty does not extend to failure resulting from an accident or disaster or from Owner or operator abuse or neglect (such as operating without proper maintenance of equipment, including pumps, filters and electrical connections.)

Service parts worn out by usage and not due to defects in workmanship or material are not covered by this Warranty.

NLI is not responsible for failure resulting from improper repair or use of defective parts or parts not approved by NLI.

NLI is not responsible for failure of product or parts resulting from improper installation or unauthorized modifications.

NLI is not responsible for failure caused by negligent handling or abuse in installation or storage in improper environment which results in corrosion or freezing damage to equipment.

NLI is not responsible for failure caused by any third party's transportation damage to NLI's product.

NLI is not responsible for damage if any warning alarm system is ignored.

NO REPRESENTATIONS AND LIMITATIONS OF IMPLIED WARRANTY

This written Warranty is in lieu of all other express warranties, obligations or limitations. If this equipment is used primarily in a commercial endeavor, no implied warranty, including that of merchantability and fitness for a particular purpose is extended. If the product is used primarily in personal, family or household use, any implied warranty, including that of merchantability and fitness for a particular purpose, shall be limited to twelve (12) months.

Some countries or states do not allow limitations on

how long an implied warranty lasts, so the above limitations may not apply to you.

No person is authorized to make any representations or promised on behalf of NLI or to modify the terms or limitations of this Warranty in any way except in writing and signed by an authorized employee of NLI.

This warranty gives you specific legal rights, and you may have additional statutory rights which vary from one country or state to another.

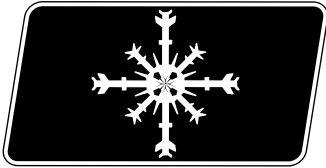

TECHNICOLD
by **NORTHERN LIGHTS**

1419 W. Newport Center Drive, Deerfield Beach, FL 33442

Tel: (954) 421-1717 • www.technicold.com

Northern Lights and Technicold are registered trademarks of Northern Lights, Inc.

© 2014 All rights reserved. Litho USA. OTCW-FX