

OPERATOR'S MANUAL

OLXE

For LX-E34 E series A.C. generator ends

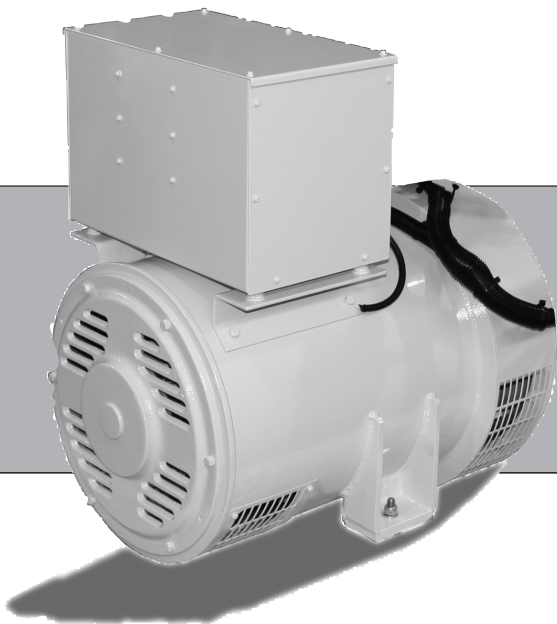

www.northern-lights.com



— CALIFORNIA —
Proposition 65 Warning:

Breathing Diesel engine exhaust and some of its constituents are known to the State of California to cause cancer, birth defects, and other reproductive harm.

- * Always start and operate the engine in a well-ventilated area.
- * If in an enclosed area, vent the exhaust to the outside.
- * Do not modify or tamper with the exhaust system.
- * Do not idle the engine except as necessary.

For more information, go to www.P65warnings.ca.gov/diesel.

Northern Lights
4420 14th Avenue NW
Seattle, WA 98107
Tel: (206) 789-3880
Fax: (206) 782-5455

Copyright ©2018 Northern Lights, Inc.
All rights reserved. Northern Lights™, and
the Northern Lights logo are trademarks of
Northern Lights, Inc.

Printed in U.S.A.
PART NO.: OPX300K2 10/18



OPERATOR'S & PARTS MANUAL OLXE

For Generator Model: LX-E 34E

*Read this manual thoroughly before starting your equipment.
This manual contains information needed to operate your set correctly and safely.*

Table of Contents

Introduction.....	4	OPERATION - GENERATOR SET	
Safety Rules	4	Starting.....	9
Models and Serial Numbers	5	Voltage Adjustment.....	9
Mechanical Construction	6	Running.....	9
		Stopping.....	9
INITIAL INSPECTION AND COUPLING		OPERATION - VOLTAGE REGULATOR	
Initial Inspection.....	6	Safety Rules	9
Coupling with Prime Mover.....	6	Operation	9
Grounding	6	Adjustment.....	9
PERFORMANCE AND FUNCTION		MAINTENANCE	
Excitation System.....	7	Bearing Inspection.....	10
Automatic Voltage Regulator (AVR)	7	Insulation Resistance Measurement Method	10
Under Speed Protection.....	7	Rotating Rectifier Assembly	10
Rotary Rectifier and Surge Suppressor	7	Parts Replacement Method.....	10 - 11
CHARACTERISTICS		Automatic Voltage Regulator Maintenance	11
Voltage Regulation.....	8	SPECIFICATIONS	
Response	8	Generator Specifications.....	12
Voltage Stability	8	Voltage Regulator Specifications.....	13
Short Circuit.....	8	TROUBLESHOOTING	14
Phase Rotation.....	8	PARTS LIST	15 - 16
STANDARD VOLTAGE SELECTION TABLE	8	WIRING DIAGRAM	
		AVR DST-100-2FAK	17
		Connection Schematic.....	18

Proprietary Information

This publication is the property of Northern Lights, Inc.

It may not be reproduced in whole or in part without the written permission of Northern Lights, Inc.

© Northern Lights, Inc. 2010. All rights reserved. Litho U.S.A. Publication number OLXE 03/10

Introduction

This manual describes procedures for operation, maintenance, inspection and adjustment. It will help the operator realize peak performance through effective, economical and safe operation.

- Read this manual carefully BEFORE operating the generator.
- Study this manual until proper operation becomes personal habit.
- Operation, inspection, and maintenance should be carried out carefully. Safety must be given the first priority.

Safety Rules

- To insure years of trouble-free operation, the specified maintenance is important and should be performed.
- **Electrical equipment should always be kept clean.** Oil, dust, moisture and salt are all harmful to generators.
- **Be careful with electricity.** Do not touch rotating parts.
- **Ambient Environmental Conditions**
 - a) **Gas:** Do not use in an environment of corrosive or flammable gas (gasoline, hydrogen sulfide, methane gas, etc.)
 - b) **Sandy Dust:** Do not use equipment in places with excessive sand and dust.
 - c) **Humidity:** Do not use in very humid environments for long periods of time.
 - d) **Salt/Seawater:** Protect your generator from exposure to salt, water, and water vapor.

- **Insulation Resistance and Dielectric:** When measuring insulation resistance and dielectric, be sure to disconnect the AVR and rectifier.
- Be sure that the regulator is shut off by switching the CPR (circuit breaker) on the AVR to the off position when the unit is running at less than rated speed, or when the unit is to be run but no power generation is required.
- Before starting your generator, be sure operating conditions are safe.
- **Ventilation:** When selecting the installation site, be sure that the area is well ventilated and that ambient temperature does not exceed 40°C.
- Be sure to provide generator with cover and protection when operating outside.

LX-E Series AC generators are based on BS 4999 part 20 and IEC34-5, IP22.

Model and Serial Numbers

GENERATOR END MODEL NUMBER

Generator Set Model No Generator Model
M944T LX-E 34E

SERIAL NUMBERS

- When referencing Northern Lights equipment by serial number, it is important to differentiate between the engine, generator end, and generator set serial numbers.
- The engine serial number is either on a metal tag or stamped directly into the engine block.
- The generator END serial number is on a metal tag attached to the generator end.
- The generator SET serial number is on a separate metal tag attached to the generator end. It may be a five by one inch tag installed directly below the generator end tag. Or, it may look like the illustrations below. Please use the generator SET number in correspondence or when ordering parts.



NORTHERN LIGHTS 			
Generator Set Data			
Set Serial	<input type="text"/>		
Set Model	<input type="text"/>		
AC Generator Data			
Model No.	<input type="text"/>		
Serial No.	<input type="text"/>		
DUTY	<input type="text"/>	WIRE	<input type="text"/>
KW	<input type="text"/>	INSUL	<input type="text"/>
KVA	<input type="text"/>	AMB°C	<input type="text"/>
RPM	<input type="text"/>	PF	<input type="text"/>
HERTZ	<input type="text"/>	VOLTS	<input type="text"/>
PHASE	<input type="text"/>	VOLTS	<input type="text"/>
°C RISE	<input type="text"/>	AMPS	<input type="text"/>
RULE	<input type="text"/>	AMPS	<input type="text"/>
 Northern Lights, Inc., WA USA www.northern-lights.com			

Figure 1: Generator Set Serial Number Plate

Mechanical Construction

STATOR

The stator frame is fabricated from rolled steel. The round construction provides rigidity and strength to resist excessive mechanical shocks. The stator core is made of high quality silicon steel plates coated with insulating film for prevention of eddy currents. The core is positioned along the internal surface of the frame. The exciter field core is made of special steel plates capable of retaining a high degree of residual magnetism.

BEARINGS

The long-life ball bearings are sealed to prevent grease from escaping and to keep dirt out.

ROTOR

The rotor shaft is made of high quality carbon steel, and is designed and manufactured to be mechanically durable. The rotor is a salient revolving field type with the main field core made from special steel plates having superior magnetic characteristics. The field core elements, exciter rotor, rotary rectifier and cooling fan are integral parts of the same shaft.

VENTILATION

Cooling is provided by the cooling fan of the rotor through suction ports and exhausted through outlet ports. Every machine conforms to the cooling code ICO1 of BS.

Initial Inspection and Coupling

INITIAL INSPECTION

If the generator is stored for long periods of time, store in a clean, dry, ventilated area. After extensive storage time, check the resistance of the coil insulation in accordance with this manual (see **MAINTENANCE**, page 11) before operation. Be sure there are no abnormal sounds or any overheating during operation.

COUPLING WITH PRIME MOVER

LX-E series single bearing generators make centering and direct coupling easy. Coupling bolt torque is 35 ft.-lb.

GROUNDING

The neutral is not grounded to the frame unless specified.

Performance and Function

EXCITATION SYSTEM

The excitation system of the LX-E Series generator uses an Automatic Voltage Regulator (AVR) which uses a portion of the output power to supply controlled DC power to the exciter field (EX) as show in Figure 2. When DC power is supplied to the exciter field, output from the exciter armature is rectified by a 3-phase bridge rotary rectifier (Si) and supplied to the main field coils. See Figure 2.

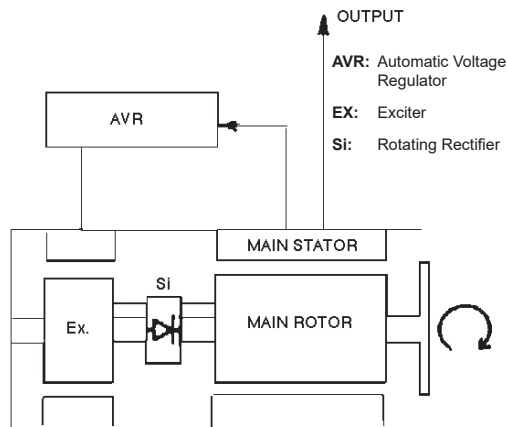

Figure 2: LX-E Block Diagram

AUTOMATIC VOLTAGE REGULATOR (AVR)

The LX-E generators use a DST-100-2FAK AVR. This is a compact voltage regulator for generators with an output up to 50kW. The AVR can be used in 120V single phase applications and is installed inside the generator junction box.

The AVR obtains sensing input from the main stator coils and compares the rectified value of the sensing voltage with the reference voltage produced inside the AVR. Input power is obtained from the main stator.

Rectified output power to the exciter field is controlled by switching a transistor on and off. This AVR will control terminal voltage even if the input sine wave is distorted.

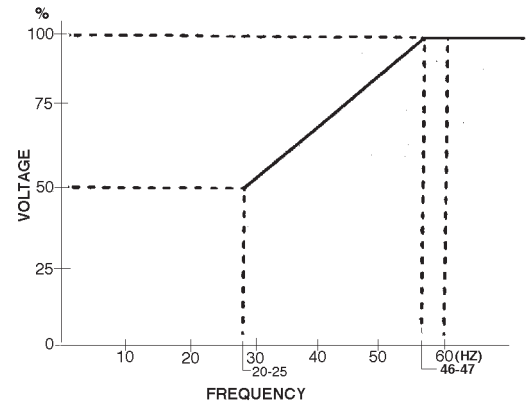

Figure 3: For 50 Hz

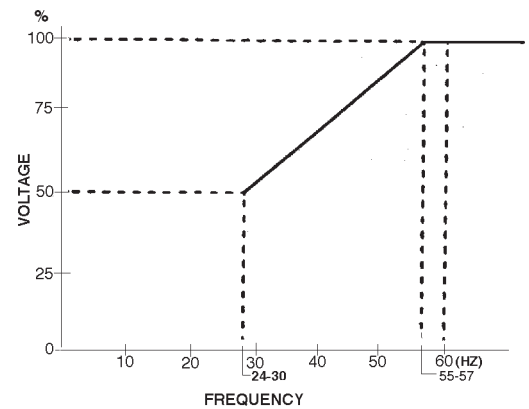

Figure 4: For 60 Hz

UNDER SPEED PROTECTION

A frequency sensing circuit is built into the AVR. When the generator speed drops to 90% of rated speed this circuit protects the AVR by reducing the voltage in proportion to the decrease in engine speed. In addition, when the generator is hit with a rapid overload, this circuit will lower the voltage to protect the engine. See Figures 3 & 4.

ROTARY RECTIFIER AND SURGE SUPPRESSOR

The rotary rectifier assembly, consisting of six diodes, functions as a 3-phase full wave rectifier for the output of the exciter armature and supplies this to the main field. To protect the diodes from large, instantaneous voltage surges, surge absorbers are provided as part of the rotating rectifier assembly.

Characteristics

VOLTAGE REGULATION

Generator terminal voltage regulation is within $\pm 1\%$ of the rated voltage in lagging power factor. 1.0 to 0.8, when the load is varied gradually from no load to full load. This value includes the temperature drift and rotating variation.

RESPONSE

After supplying a load instantaneously, the generator voltage should be restored to the steady condition in accordance with BS4999 Part 40, grade VR2.11 to VR2.23.

VOLTAGE STABILITY

In constant load and engine speed, voltage stability remains 0.25% of the rated voltage.

SHORT CIRCUIT

LX-E Series AC generators can provide over 300% of the rated current for a short period of time, with an excitation support system.

PHASE ROTATION

Phase sequence is T1-T2-T3 (U-V-W, A-B-C) with a counterclockwise rotation of generator viewed from the anti-coupling side.

Standard Voltage Tables and Connection Diagrams

Standard voltage selection table and connection diagram for LX-E Series 3-phase 12-wire AC generators. See AC wiring schematic page 19.

Winding Connection	Frequency	Voltages			
3 Phase Series Star (High Wye)	60 Hz	480/277	460/266	440/254	416/240
	50 Hz	415/240	400/231	380/219	
3 Phase Parallel Star (Low Wye)	60 Hz	240/139	230/133	220/127	208/120
	50 Hz	208/120	200/115	190/110	
1 Phase	60 Hz	120/240			
	50 Hz	100/200	110/220	115/230	120/240

Figure 5: Standard Voltage Table

Operation – Generator Set

STARTING

Before starting generator, check the following:

1. Make sure that the wiring is correct.
2. Be sure that nothing is blocking the air inlet/ outlet.
3. Make sure that the inside of the generator is clean.
4. Be sure the main line circuit breaker is switched OFF.

After checking each of the above, start the generator in the following procedure:

1. Start engine in accordance with instructions in the Operator's Manual. Be sure there is no abnormal sound or vibration.
2. The voltage will rise due to the increase in generator speed. After making sure that each interphase voltage is balanced, set the voltage and frequency to the rated level. Be sure the CPR switch is "ON". The voltage will not rise with CPR "OFF".
3. After running the generator without load, switch the circuit breaker ON to start the load operation.

VOLTAGE ADJUSTMENT

The generator has been adjusted to obtain optimum voltage at the factory. If the voltage is different, adjust the voltage with the Voltage Adjust provided on the AVR.

RUNNING

Check the following while operating the generator:

1. Abnormal vibration and/or sound
2. Load
3. Environment:

Keep the air inlet/outlet clean and clear for optimum cooling. Insufficient cooling causes overheating of the generator.

Note: *When a 3-phase generator is used at single phase load, each phase current should be balanced and should not exceed 50% of the rated current.*

STOPPING

After putting the running generator in a no-load condition by removing the generator load, stop the engine in accordance with the Engine Manual.

Operation – Automatic Voltage Regulator

SAFETY RULES

- Do not leave AVR connected when testing generator with high-pot or megger.
- Adjust the engine only when the CPR is in "OFF" position.

OPERATION

1. Make sure the wiring is correct.
2. Make sure the frequency selection switch is set to the rated frequency (60 or 50 Hz).
3. To adjust the voltage turn the Voltage Adjust (VR1) counter-clock wise. Make sure the CPR is "ON".
 - a. Start the engine with no load and increase the engine speed slowly to the rated level. The voltage will automatically build up (residual voltage: more than 10V).
 - b. Adjust to the rated voltage using the Voltage Adjust (VR1).
 - c. Make sure of the proper Volt/Frequency characteristic by reducing the generator speed.
 - d. Make sure of voltage stability by switching the load "ON" or "OFF". Use the Stability Adjust (VR2).
 - e. If you find no problem with the AVR, start the normal operation.

ADJUSTMENT

Each component of the AVR is adjusted at the factory to obtain optimum voltage. If readjustment is necessary, make sure the voltage, frequency, load, etc. are functioning properly after readjustment.

1. **Initial Excitation:** *For initial excitation use a DC12V or DC24V battery.*
 - a. Stop the generator.
 - b. Remove the AVR connectors.
 - c. Connect the field terminal F(+) with the polarity (+) of battery and the terminal F (-) with the polarity (-) and excite AVR field for 2 or 3 seconds.
2. **Voltage Adjustment:**

If the voltage output is low, increase the voltage by turning the Voltage Adjust (VR1) slowly clockwise.
3. **Stability:**

If the voltage output is unstable, increase the voltage by turning the Stability Adjust (VR2) clockwise.
4. **Voltage and Frequency:**

Voltage and Frequency (Hz) have been preset at the factory.

Maintenance

BEARING INSPECTION

For bearing inspection, make sure that there is no abnormal sound during normal running and no overheating. Greasing is not necessary for generators using the double seal type ball bearings, but these will need to be replaced after every 10,000 hours of operation (see **PARTS REPLACEMENT METHOD**).

INSULATION RESISTANCE MEASUREMENT

If the generator has not been used for a long time, check the insulation resistance of each lead wire at 500V with a megger.

It is usually enough to check only the stator winding. In order to prevent damage to the AVR, disconnect it. If the measured insulation resistance value is above 2 M ohms, there is no problem, but if it is lower than that, check to see if the inside of the generator is wet or dirty. If dust has accumulated, blow it out with dry compressed air. Wipe off oil stains with a cloth. If the generator is damp, dry it and re-check.

ROTATING RECTIFIER ASSEMBLY

The rotating rectifier assembly needs little attention. Clean off dust and oil stains periodically. In the unlikely event that it becomes necessary to replace the diode elements and surge absorber elements. Refer to **PARTS REPLACEMENT METHOD**.

PARTS REPLACEMENT METHOD

1. Bearing Replacement:
 - a. In order to replace the bearing, first remove the bearing holder housing on the end of the generator. Loosen and remove the four housing bolts. Remove the bearing holder gently since there is a risk that the rotor could fall and damage the exciter rotor or the exciter stator.

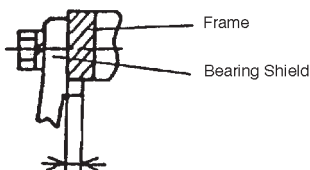

Figure 6. Pilot Length

- b. Using a bearing puller, extract bearing from shaft.
- c. When installing a new bearing, place a steel pipe on the inner race surface, and fit the bearing by tapping it lightly with a hammer.

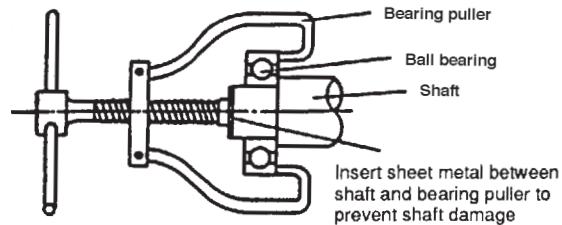

Figure 7. Bearing Puller

Note: Absolutely do not apply pressure to outer race of the bearing during insertion.

2. Replacement of Rotary Rectifier Parts:
 - a. Rotary rectifier parts are all located at the rear of Exciter rotor. For parts replacement, remove the bearing shield.
 - b. To test the rotating rectifier diodes, disconnect the lead to the diode element and measure the resistance between the anode and cathode on each diode (see Figure 8).

Caution: Do not overheat the diodes. If the resistance value of the diode in the forward direction is low and the reverse direction resistance value shows infinity, it is good. If this is not the case, the diode element is defective and must be replaced. The diode elements can be damaged if overtightened.

- c. “J” type diode elements are fastened to the J(+) side of the rotating rectifier assembly, and “K” type diode elements to the K(-) side.

Maintenance, *continued*

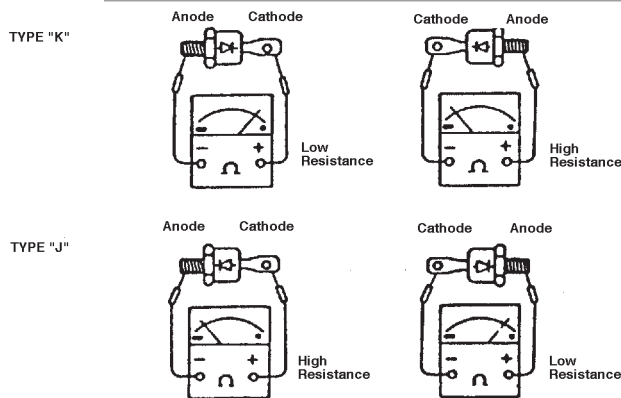

Figure 8. Testing Diode Elements

- d. The Diode Torque Specifications for LX-E models is **5 mm = 48 in. lb.**
 - e. In order to test whether the rotating rectifier assembly surge absorber elements are good or not, first disconnect all lead wires as described in **PARTS REPLACEMENT METHOD**, Point 2, (above) and measure the resistance across surge absorber elements with a tester.
 - Good surge absorber elements have about 10-30 K ohms, but if the resistance reading is near 0 ohms, the surge absorber elements is defective and must be replaced.
 - Also, inspect outside of surge absorber and replace if it is cracked.
 - In addition, when installing surge absorber elements, apply Loctite to the bolts.
3. Bearing Housing Replacement:
Inspect the O-Ring. If cracked, replace.
Reassemble carefully, aligning housing with bearing. Tighten housing bolts to 2.5 kpm (18 ft/lbs.).

4. Rotating Rectifier Assembly Detailed Structure:

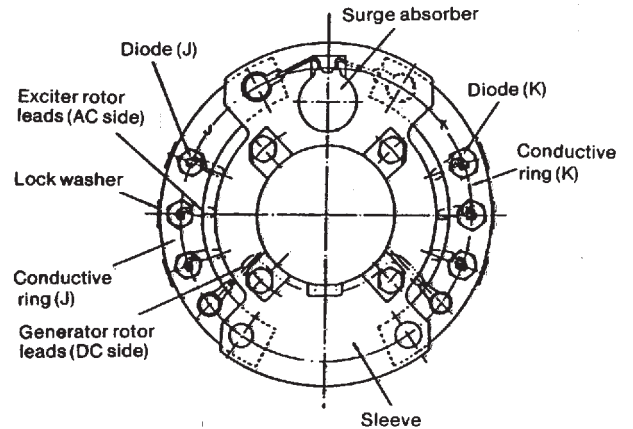

Figure 9. Rotating Rectifier.

Maintenance – Automatic Voltage Regulator

1. Keep the AVR clean at all times. Make sure no dust or moisture accumulates on the AVR.
2. Inspect periodically making sure that wiring connections are not loose.

Generator Specifications: Taiyo Winding Resistances for LX-E 34E

All ratings in Ohms @ 20° C

1 or 3 Phase		
MAIN STATOR:	0.0580 V	
1 or 3 Phase		
MAIN ROTOR:	3.3 V	
1 or 3 Phase		
EXCITER STATOR:	16.4 V	
1 or 3 Phase		
EXCITER ROTOR:	0.629 V	
1 or 3 Phase		
AUXILIARY WINDING:	1.34 V	
	1 Phase	3 Phase
FULL LOAD EXCITATION VOLTAGE:	50 Hz/ 220 volts 21.2 volts 60 Hz/ 240 volts 19.0 volts	50 Hz/ 220 volts 31.3 volts 50 Hz/ 400 volts 29.0 volts 60 Hz/ 208 volts 24.6 volts 60 Hz/ 480 volts 27.0 volts

Automatic Voltage Regulator: DST-100-2FAK

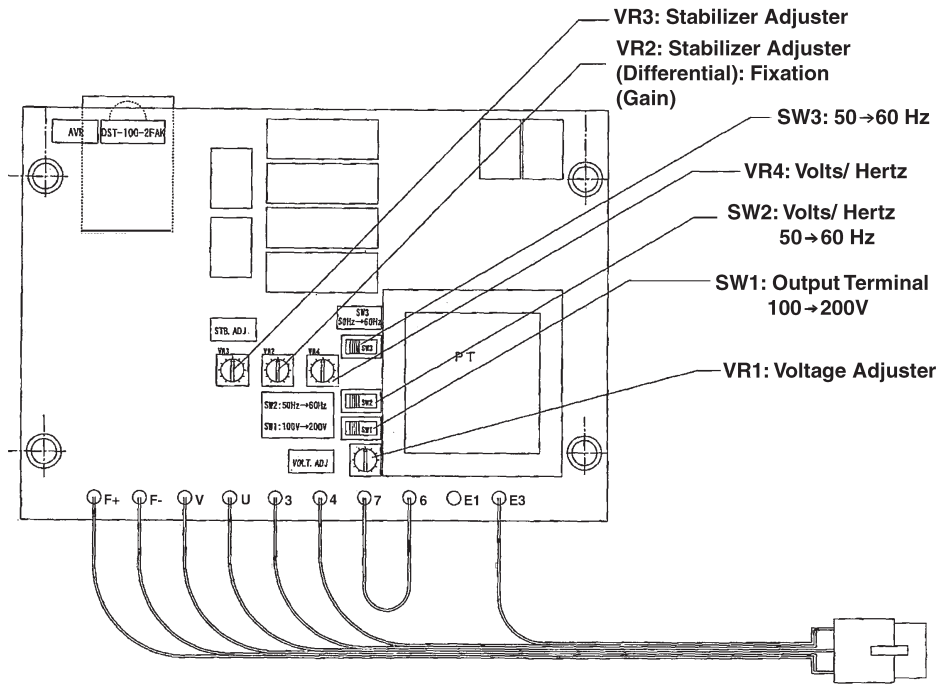

Sensing Output Voltage	Frequency	50 Hz	60 Hz
	100 Volt Class	100V (86.5V~110V~120V)	120V
	200 Volt Class	200V (173V~220V~240V)	240V
	Phase:	Single Phase	Single Phase

Power Input	Voltage:	100V ~ 127V ~	139V
	Frequency:	50 Hz /	60 Hz
	Phase:	Single Phase	Single Phase

Sensing Output (F+) – (F-)	Max. Voltage:	87% of Power Input Voltage (DC Voltage)	
	Continuous Current:	Maximum 3A Current	
	Current Maximum Forcing:	9A forcing 1 to 5 seconds at 25°C	
	Field Resistance:	Minimum 15 Ohms	

Voltage Adjust Range	Minimum ±5% of Normal Voltage
Volt/ Hertz Characteristic	57 Hz in 60 Hz operation mode, 47 Hz in 50 Hz operation mode
Voltage Build-Up	Self-Building Up at over 6V Power Input Voltage
Voltage Changeable Rate	Maximum ±1.5%
Temperature Drift	Within ±0.02%/ degree C
Operating Temperature	-4°F (-20°C) to 140°F (60°C)
Storage Temperature	-4°F (-20°C) to 158°F (70°C)
Outside Dimension	5.6" x 4.0" x 1.57" (140mm x 100mm x 40 mm)
Weight	1.4 lbs. (0.65 kgs)

Trouble Shooting

PROBLEM	POSSIBLE CAUSE	RECOMMENDATION(S)
Only a FEW VOLTS of output	Loss of residual magnetism of the exciter field Disconnection or short circuit of windings Defective AVR Defective rotating rectifier assembly	<ul style="list-style-type: none"> • Flash field. • Check the insulation of all windings and check the resistance value. • Check the AVR. • Replace diode elements.
Voltage is LOW	Incorrect wiring (GEN, AVR) Low speed Overload Defective AVR	<ul style="list-style-type: none"> • Check the winding connection. • Check the engine. • Reduce the load. • Check the AVR.
Voltage DIPS when on load	Starting of big motor or spot welding machine Defective diode on rotating rectifier [F(+) – F(-) terminal voltage will show a very high value when a diode is defective]	<ul style="list-style-type: none"> • About 15% voltage dip is no problem. • Change diode.
Voltage is HIGH	Incorrect wiring (GEN, AVR) Too high speed Defective AVR	<ul style="list-style-type: none"> • Check the AVR. • Check the engine. • Check the AVR.
Voltage FLUCTUATES	Wiring leads are loose Irregular speed of engine Poor AVR adjustment External noise	<ul style="list-style-type: none"> • Tighten leads. • Check the engine. • Check the AVR. • Check the filter.
Abnormal SOUND or VIBRATION	Foundation uneven Poor mounting Misaligned coupling Defective bearing	<ul style="list-style-type: none"> • Check ground level. • Check the mounting section. • Check the coupling section. • Replace the bearing.

LX-E Parts List

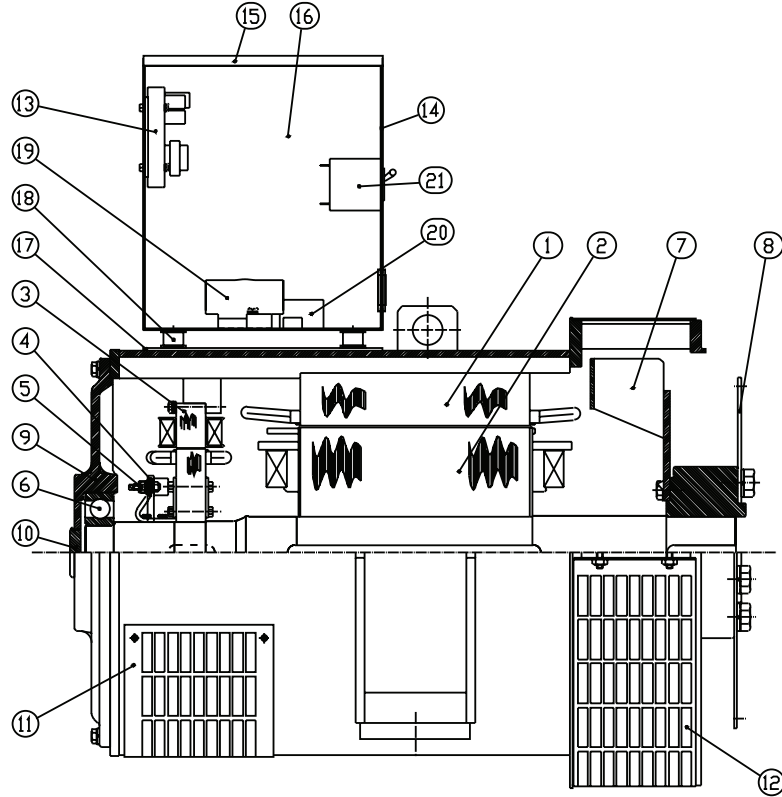

3T102-435

No		Description	LX-E 34E	
1	Stator Assembly	GW-20650-STF	with frame GM304980-1	
2	Rotor Assembly	GM304982		
3	Exciter Field Assembly	WKC-0131-F		
4	Rectifier Assembly	3T201-084-3	with diode element	
5	Diode Element	SKN 26/12		
	Diode Element	SKR 26/12		
6	Bearing	6311ZZ		
7	Fan Assembly	GM34865-2	with coupling boss GM405464	
8	Coupling Plate	4M698-011-1		
9	Bearing Shield	GM34467-3		
10	Rubber Cap	GM403175		
11	Ventilation Cover	GM413645	Inlet	
12	Ventilation Cover	GM413639	Outlet	
13	Automatic Voltage Regulator	22-42071		
14	Junction Box	3T303-671		
15	Top Cover, Junction Box	4T302-144		
16	Side Cover, Junction Box	4T302-859		
17	Bracket, Junction Box	3T303-672	Left and right	
18	Rubber Mount	33-40007		
19	Terminal (Output)	22-45413		
20	Terminal	UK150-3J		
21	Circuit Breaker 3 Amp	22-42077		

Junction Box (Single Phase Wiring Shown)

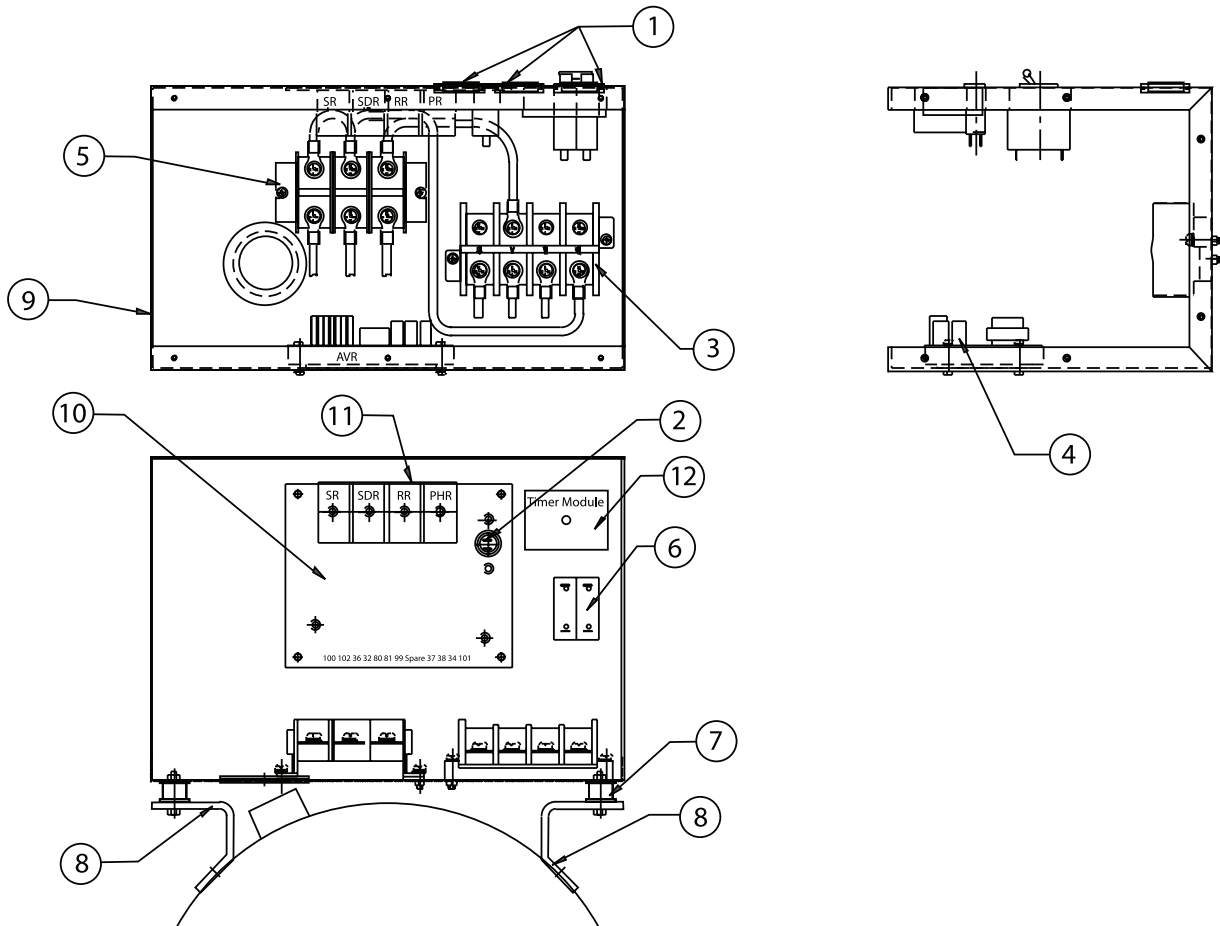

3T102-430-2

Key	Description	Part Number	
1	Grommet	NG-79-R	
2	Circuit Breaker	22-40018	
3	Terminal	22-45413	
4	Automatic Voltage Regulator (DST-100-2FAK)	22-42071	
5	Terminal	UK150-3J	
6	Circuit Breaker 3 Amp	22-42077	
7	Rubber Mount	33-40007	
8	Bracket, Junction Box Mtg. - Right and left	3T303-672	
9	Junction Box	3T303-671	
10	Relay Board Sub-Assembly	22-70083-1	Manual Start
	Relay Board Sub-Assembly	22-70086-1	Autostart
11	Relay 12 Volt (4 ea.)	22-42047	
	Relay 24 Volt (4 ea.)	22-40085	
12	Timer Module 12 Volt	22-40407	
	Timer Module 24 Volt	22-40408	

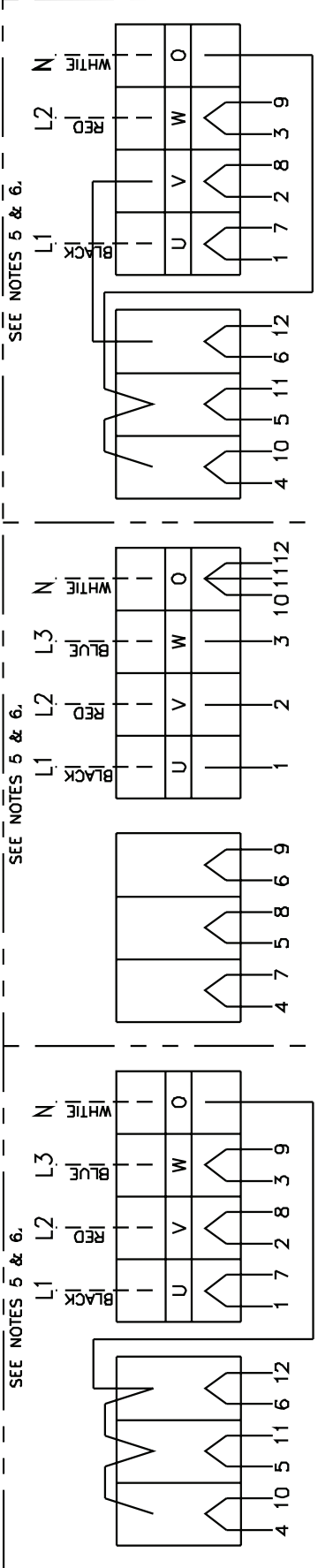

12 WIRE LOW WYE
 120/208 3 ϕ 60 HZ.
 127/220 3 ϕ 50 HZ.
 SEE NOTE 4.

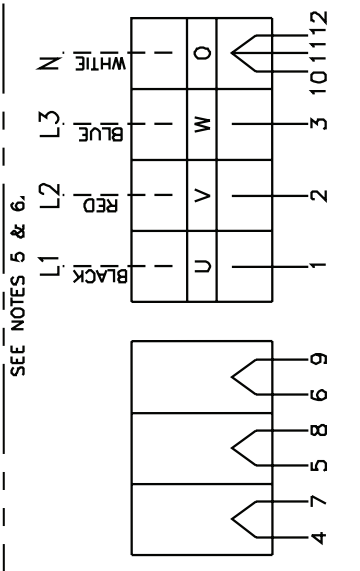

12 WIRE HIGH WYE
 277/480 3 ϕ 60 HZ.
 231/400 3 ϕ 50 HZ.
 SEE NOTE 4.

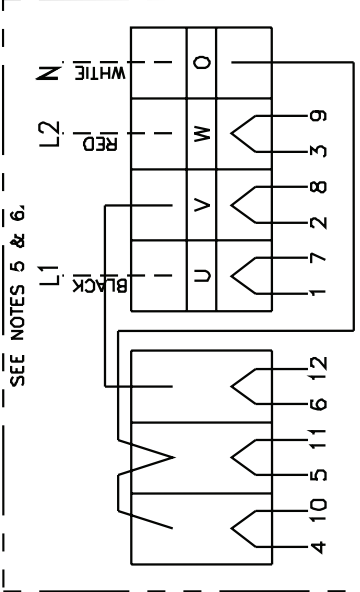

12 WIRE ZIG ZAG
 120/240 1 ϕ 60 HZ.
 220 1 ϕ 50 HZ.
 SEE NOTE 4.

NOTES:

1. SET SW2 FOR CURRENT APPLICATION, (50 OR 60 HZ.)
2. SET SW3 PER APPLICATION IF REMOTE VOLTAGE ADJUST RHEOSTAT IS USED.
3. FOR REMOTE VOLTAGE ADJUST RHEOSTAT CUT JUMPER AND SPLICE INTO PURPLE LEADS.
4. DELETE NEUTRAL CONDUCTOR (AND JUMPER IF PRESENT), IF LOWER VOLTAGE IS NOT REQUIRED.
5. GROUNDED IS TO BE BY CUSTOMER, AT CUSTOMER'S DISCRETION.
6. HIDDEN (DASHED) LINES INDICATE CUSTOMER SUPPLIED AND CONNECTED MAIN OUTPUT CONDUCTORS, SIZING TO BE DETERMINED PER INSTALLATION.

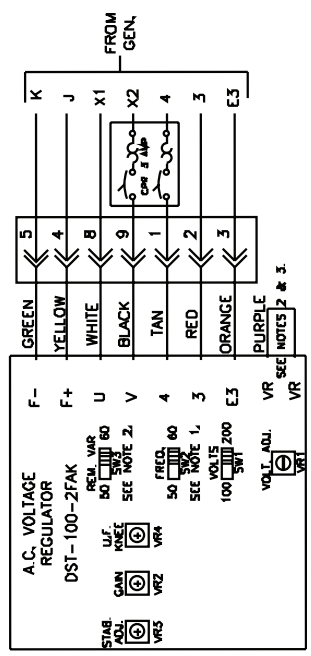

AC Wiring Schematic - B-9582
 DST-100-2FAK, All Voltages

CONNECTION BOX

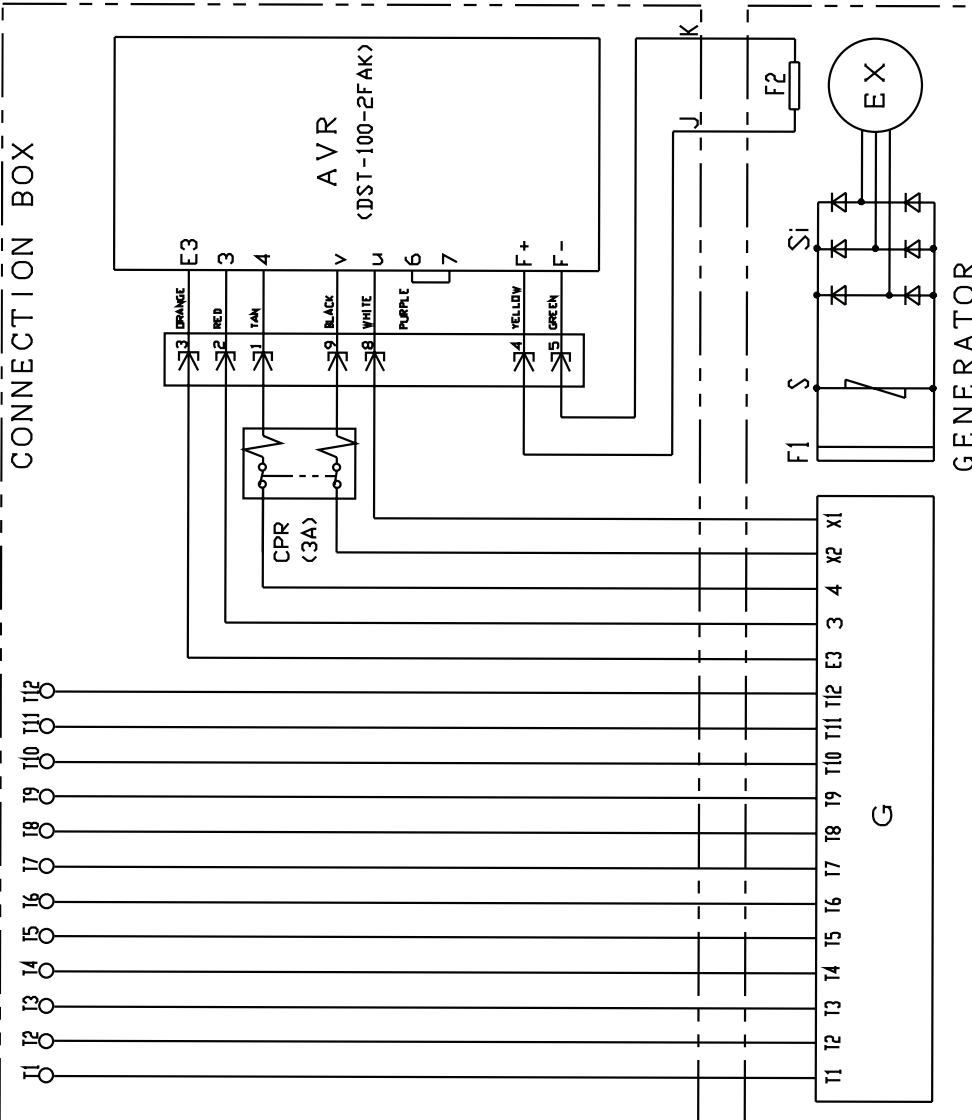

* FOR 120V NOMINAL SENSING : CONNECT TO TERMINAL 100.
 FOR 240V NOMINAL SENSING : CONNECT TO TERMINAL 200.

SYMBOLNAME OF PARTS	SYMBOLNAME OF PARTS
G	GENERATOR
EX	EXCITER
F1	GENERATOR FIELD
S	SURGE ABSORBER
S1	SILICON RECTIFIER
AVR	AUTO. VOLT. REGULATOR
CPR	CIRCUIT PROTECTOR

VOLTAGE SELECTION AND INTERNAL CONNECTION

60HZ : 480/277V
 50HZ : 400/231V

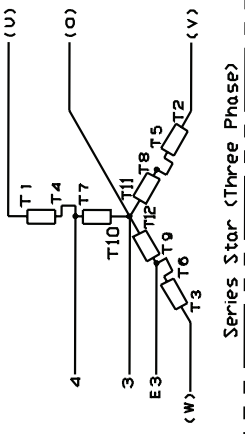

Series Star (Three Phase)

60HZ : 208/120V
 50HZ : 220/127V

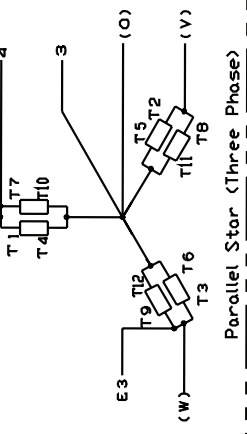

Parallel Star (Three Phase)

60HZ : 240/120V
 50HZ : 220V

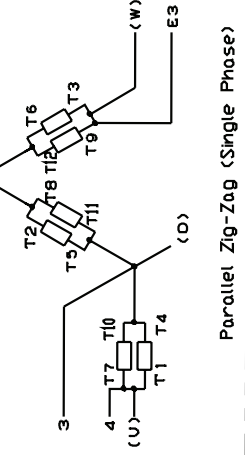

Parallel Zig-Zag (Single Phase)

Connection Schematic
 3T103-437



NORTHERN LIGHTS
4420 14th AVE. N.W.
SEATTLE, WA 98107-5043
USA

TEL: (206) 789-3880
FAX: (206) 782-5455
<http://www.northern-lights.com>