

PLAN

EST. WEIGHT AND C.G.				
MODEL	WEIGHT	C.G.		
	LBS.	X	Y	Z
M116A13.11L (116kW/60Hz)	3500	-.19	-.31	2.26
M116A13.51L (116kW/50Hz)	3645	.90	-.30	2.17

NOTE: WEIGHTS INCLUDE OIL, NO COOLANT.

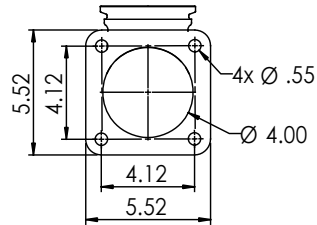

OPTIONAL DRY EXHAUST ELBOW
SCALE 1:4

ITEM	DESCRIPTION
1	EXPANSION TANK
2	COOLANT FILL
3	SEAWATER INLET - Ø 2.0 H.B.
4	SEAWATER OUTLET (DRY EXHAUST) - Ø 2.0 H.B.
5	OPTIONAL WET EXHAUST ELBOW - Ø 6.0 H.B.
6	FUEL SUPPLY - 3/8 NPT
7	FUEL RETURN - 3/8 NPT
8	CRANKCASE OIL FILL/DIPSTICK
9	CRANKCASE OIL FILTER
10	ENGINE OIL DRAIN - 1/2 NPT
11	AIR INLET FILTER
12	OPTIONAL DRY EXHAUST ELBOW - SEE DETAIL
13	CLOSED CRANKCASE VENTILATION SYSTEM
14	ELECTRIC STARTER
15	PRIMARY FUEL FILTER
16	FINAL FUEL FILTER
17	ENGINE CONTROL UNIT
18	PMG
19	D.C. JUNCTION BOX
20	BASE PAN DRAIN - 1/2 NPT

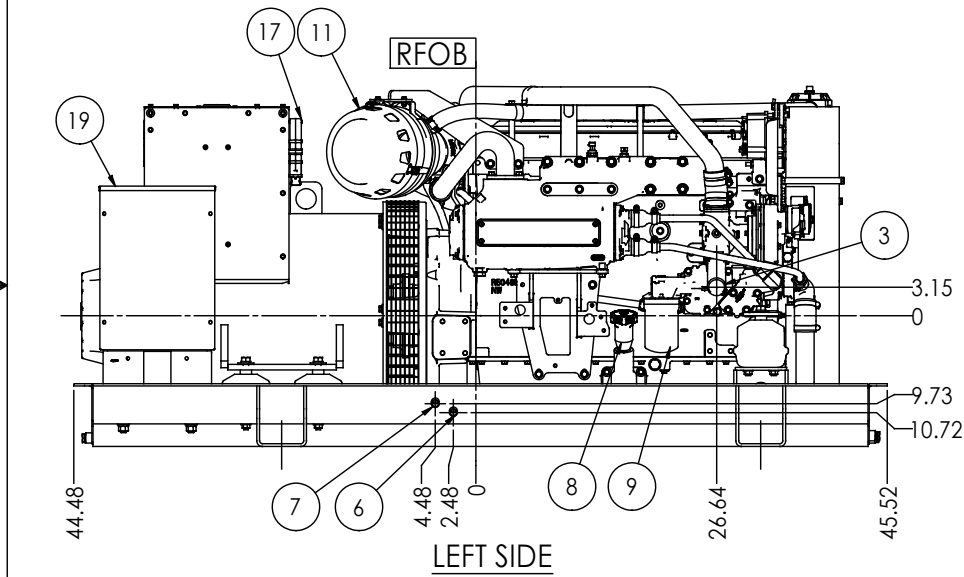

LEFT SIDE

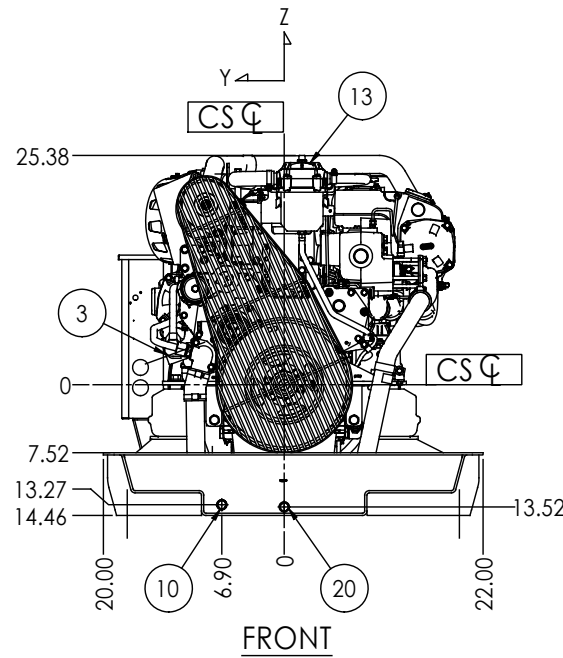

FRONT

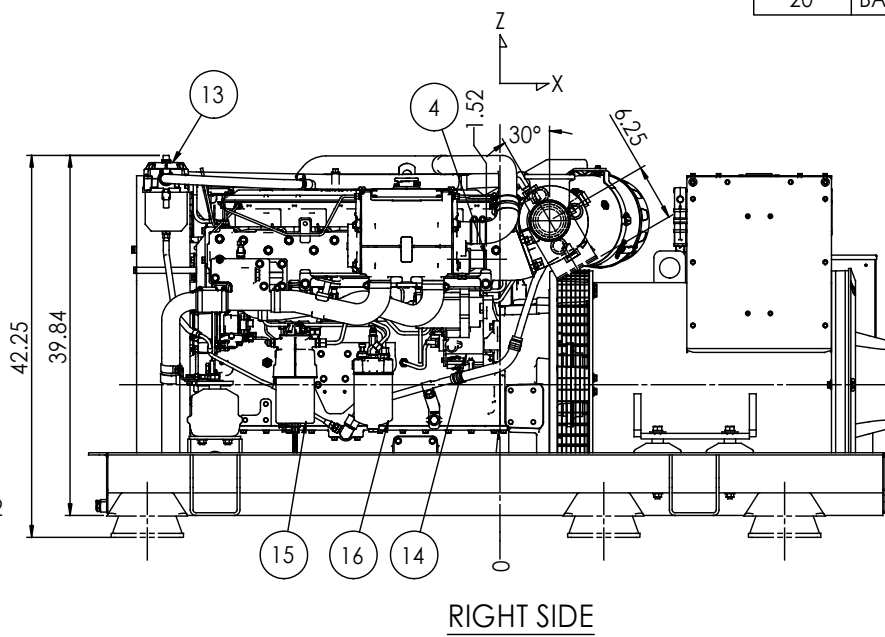

RIGHT SIDE

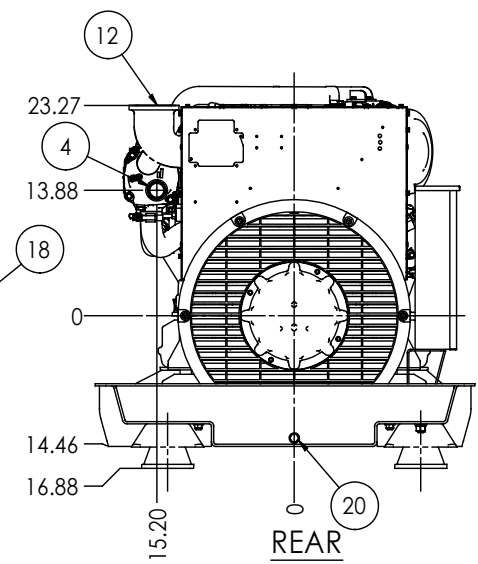

REAR

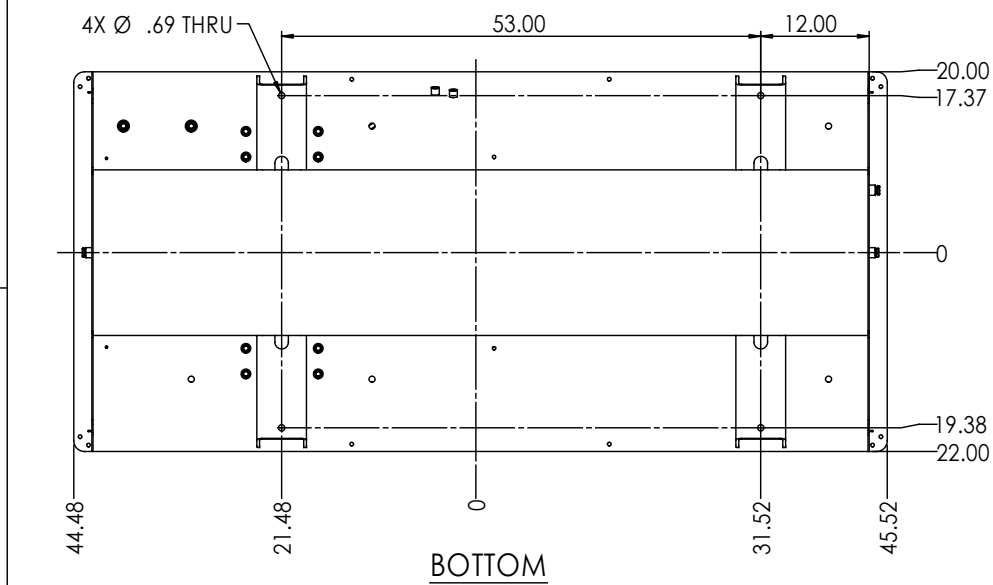

BOTTOM

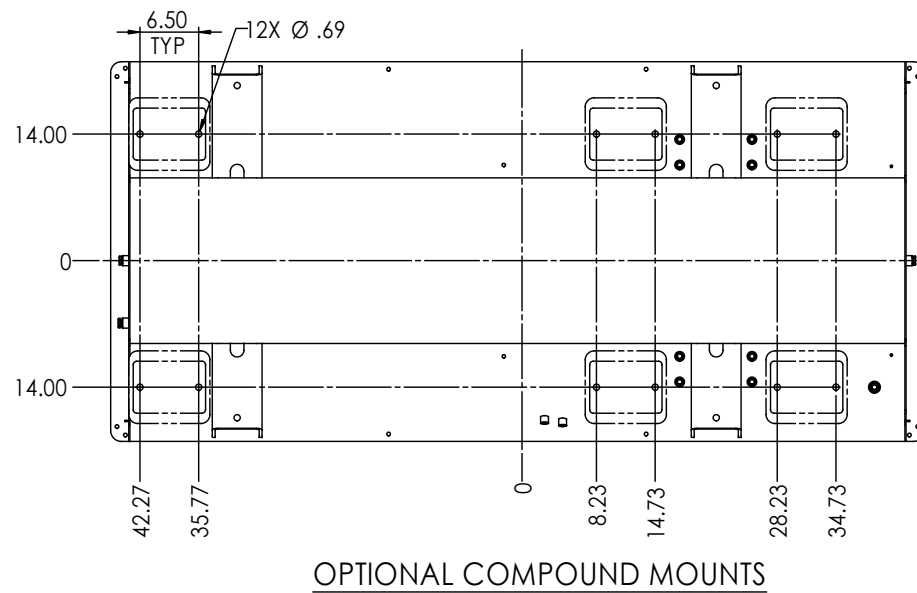

OPTIONAL COMPOUND MOUNTS

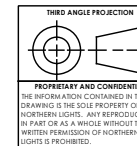

PROPRIETARY AND CONFIDENTIAL
THE INFORMATION CONTAINED IN THIS
DRAWING IS THE SOLE PROPERTY OF
NORTHERN LIGHTS. ANY REPRODUCTION
IN PART OR AS A WHOLE WITHOUT THE
WRITTEN PERMISSION OF NORTHERN
LIGHTS IS PROHIBITED.

UNLESS OTHERWISE SPECIFIED:		NAME	DATE
DIMENSIONS ARE IN INCHES		MG	06/22/17
TOLERANCES:		CHECKED	TAH
ANGULAR		ENG APPR.	
MACHES @ 10°	BEND ± 1.0°	IMG APPR.	
X ± 0.1		Q.A.	
XX ± 0.05		COMMENTS:	
XXX ± 0.005			
INTERPRET GEOMETRIC TOLERANCING PER ASME Y14.5M			
MATERIAL:			
FINISH:			
DO NOT SCALE			

NORTHERN LIGHTS		4420 14th AVE. N.W. Seattle, WA 98107 (206) 789-3880 www.northern-lights.com	
TITLE: INSTALLATION DIMENSIONS M116A13L HEAT EXCHANGER COOLED			
SIZE	PART NO.	DWG. NO.	REV
D		D-5243	
SCALE: 1:10	WEIGHT: LBS.	SHEET 1 OF 1	

D-5020