

| MODEL        | RATING | PHASE | FREQUENCY | VAC |
|--------------|--------|-------|-----------|-----|
| M673L3G.3-IP | 6 KW   | 1     | 60 Hz     | 240 |
| M673L3G.3-IP | 6 KW   | 1     | 50 Hz     | 230 |
| M673L3G.3-IP | 5 KW   | 1     | 60 Hz     | 120 |

INTAKE AIR FILTER TOP OIL FILL COOLANT FILL

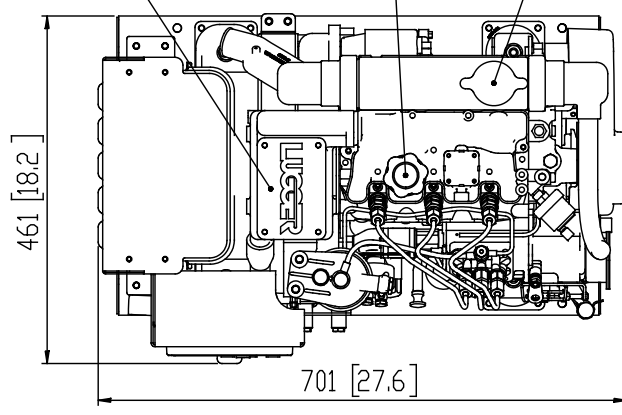

PLAN VIEW

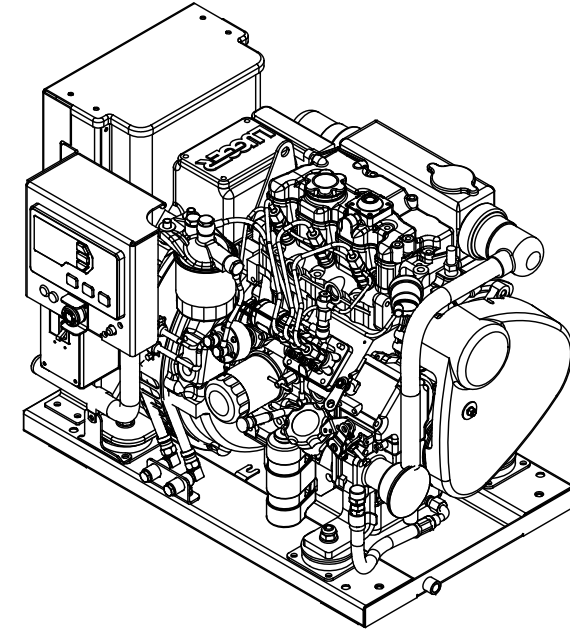

ISOMETRIC VIEW

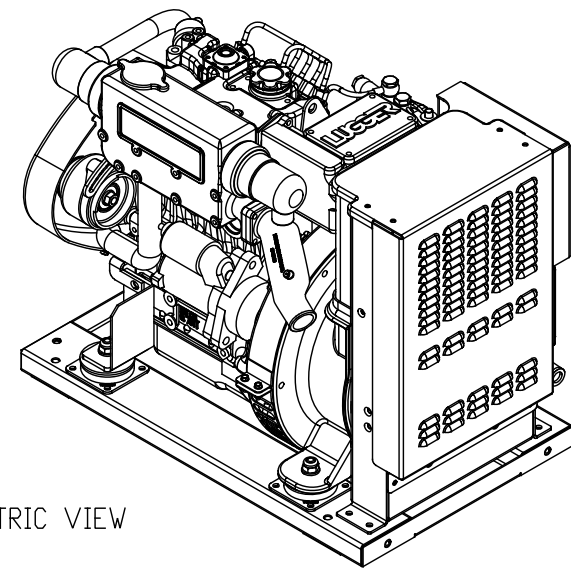

S-TSC AUTOSTART CONTROL MODULE EMERGENCY STOP SWITCH OUTPUT BREAKER

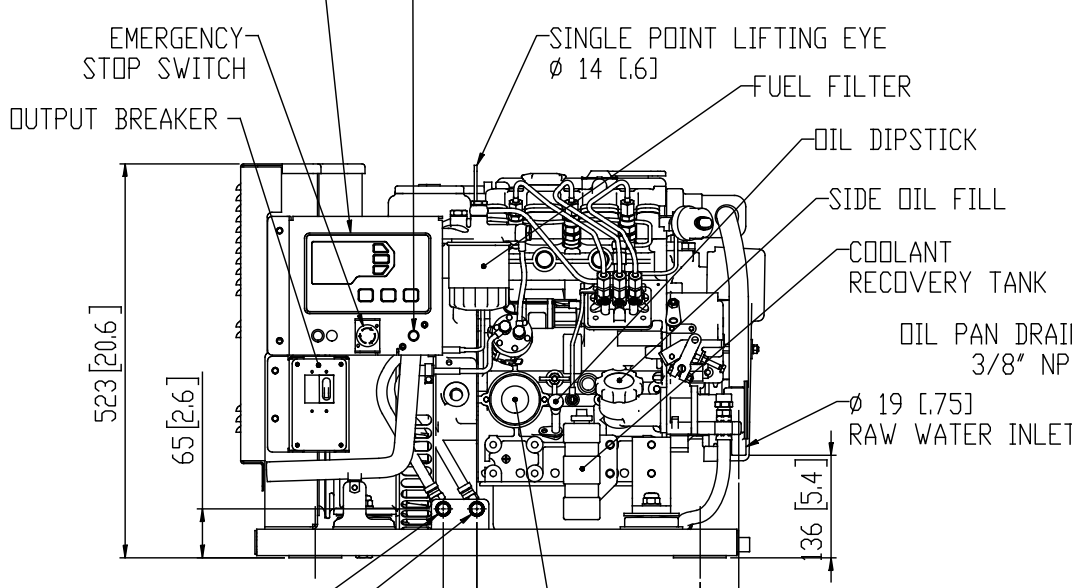

RIGHT (SERVICE) SIDE VIEW

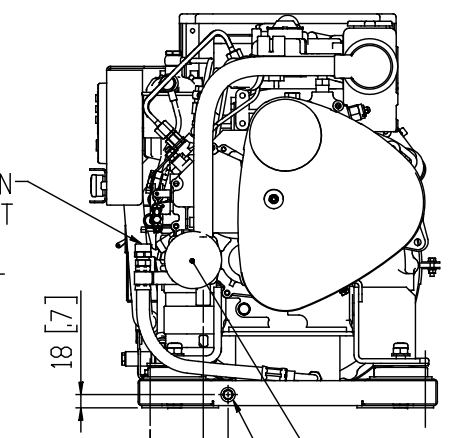

FRONT SIDE VIEW

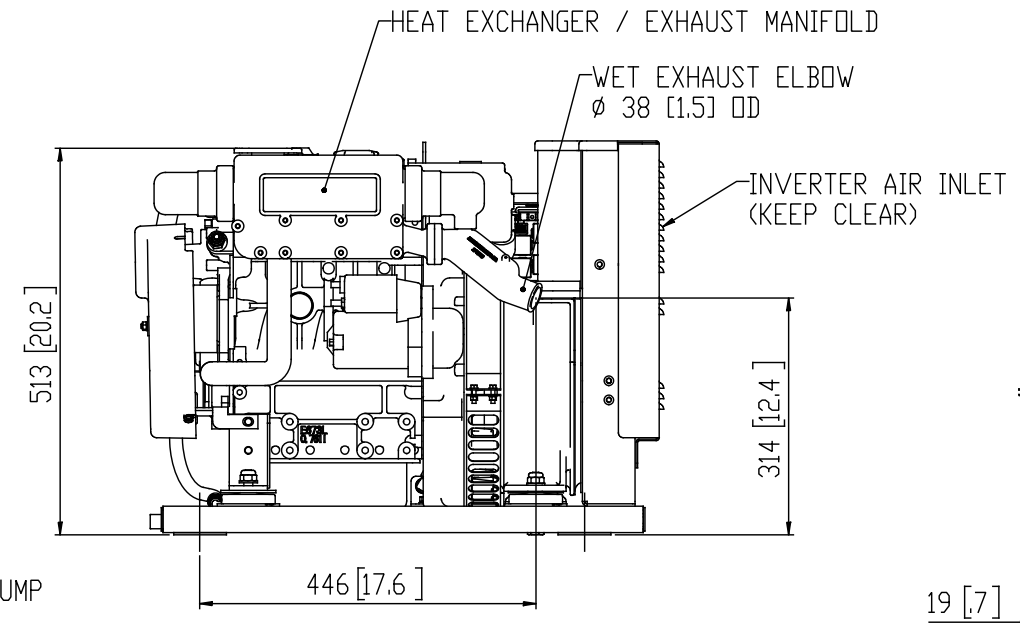

LEFT SIDE VIEW

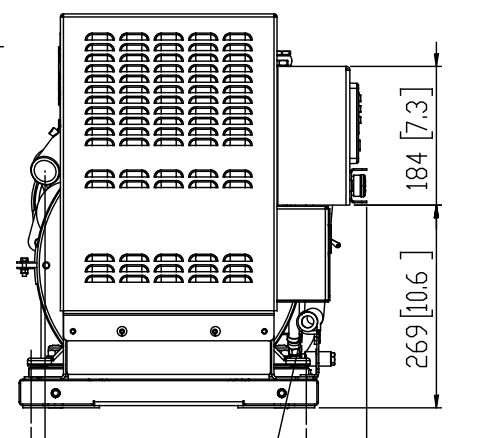

REAR VIEW

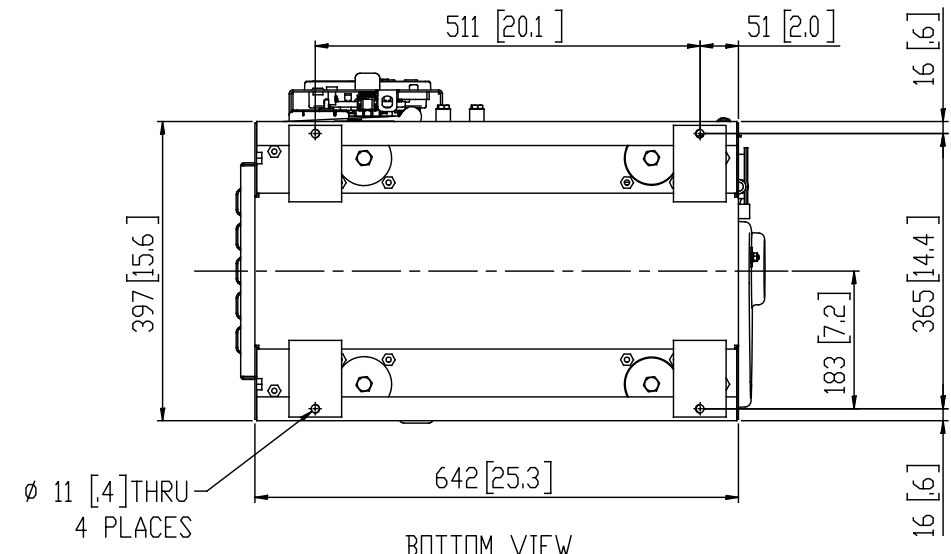

BOTTOM VIEW

NOTES  
 1. THE DIMENSIONS ON THIS DRAWING ARE SUBJECT TO CHANGE. PLEASE CONTACT NORTHERN LIGHTS INC. TO BE SURE YOU HAVE THE MOST CURRENT VERSION.

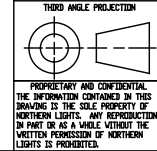

| REV. | DESCRIPTION   | DATE      | BY | CHECKED |
|------|---|-----------|----|---------|
| A    | UPDATED APPLICATION TABLE AS BUILT, ADDED WEIGHT AND REVISED INTAKE HESE. ECN# 7878 | 3/25/2022 | MK | TAH     |

| NAME        | DATE    |
|-------------|---------|
| DRAWN MK    | 1/10/21 |
| CHECKED AZB | 1/10/21 |
| ENG APPR.   |         |
| MFG APPR.   |         |
| QA          |         |

|   |                        |   |
|---|------------------------|---|
| NORTHERN LIGHTS                             |                        | 4420 14th AVE, N.W.<br>Seattle, VA 98107<br>(206) 789-3888<br>www.northern-lights.com |
| TITLE: INSTALLATION DIMENSIONS M673L3G.3-IP |                        |   |
| SIZE: D                                     | PART NO: SEE TABLE     | DWG. NO: D-5431   |
| SCALE: 1/5                                  | WEIGHT: 160 kg (350LB) | SHEET 1 OF 1  |

D-5431