

MODEL	DESCRIPTION	APPROX. WT. LBS [kg]
M4105A1	90 KW.E @ 1500 RPM (50HZ), HEAT EXCHANGED	2604 [1181]
M4105A2	105 KW.E @ 1500 RPM (50HZ), HEAT EXCHANGED	
M4105A3	116 KW.E @ 1500 RPM (50HZ), HEAT EXCHANGED	

NOTE: WEIGHT INCLUDES OIL, BUT NO COOLANT. VALUES ARE APPROXIMATIONS AND ARE SUBJECT TO CHANGE. PLEASE CONTACT NLI TO BE SURE YOU HAVE THE LATEST REVISION.

ITEM	DESCRIPTION	ITEM	DESCRIPTION
1	SEAWATER INLET (Ø 2.0 H.B.)	14	ENGINE OIL FILL
2	HEAT EXCHANGER	15	FUEL RETURN PORT (3/8" NPT)
3	COOLANT FILL	16	FUEL SUPPLY PORT (3/8" NPT)
4	AFTERCOOLER	17	OIL DRAIN PORT (1/2" NPT)
5	OPTIONAL WET EXHAUST ELBOW (Ø 5" H.B)	18	ALTERNATOR
6	ELECTRIC STARTER MOTOR (12V STD/ 24V OPT)	19	
7	EXPANSION TANK	20	
8	THERMOSTAT HOUSING	21	
9	FUEL/WATER SEPERATOR	22	
10	FINAL FUEL FILTER	23	
11	OIL FILTER	24	
12	AIR FILTER & COALESCING FILTER	25	
13	ENGINE OIL DIPSTICK	26	

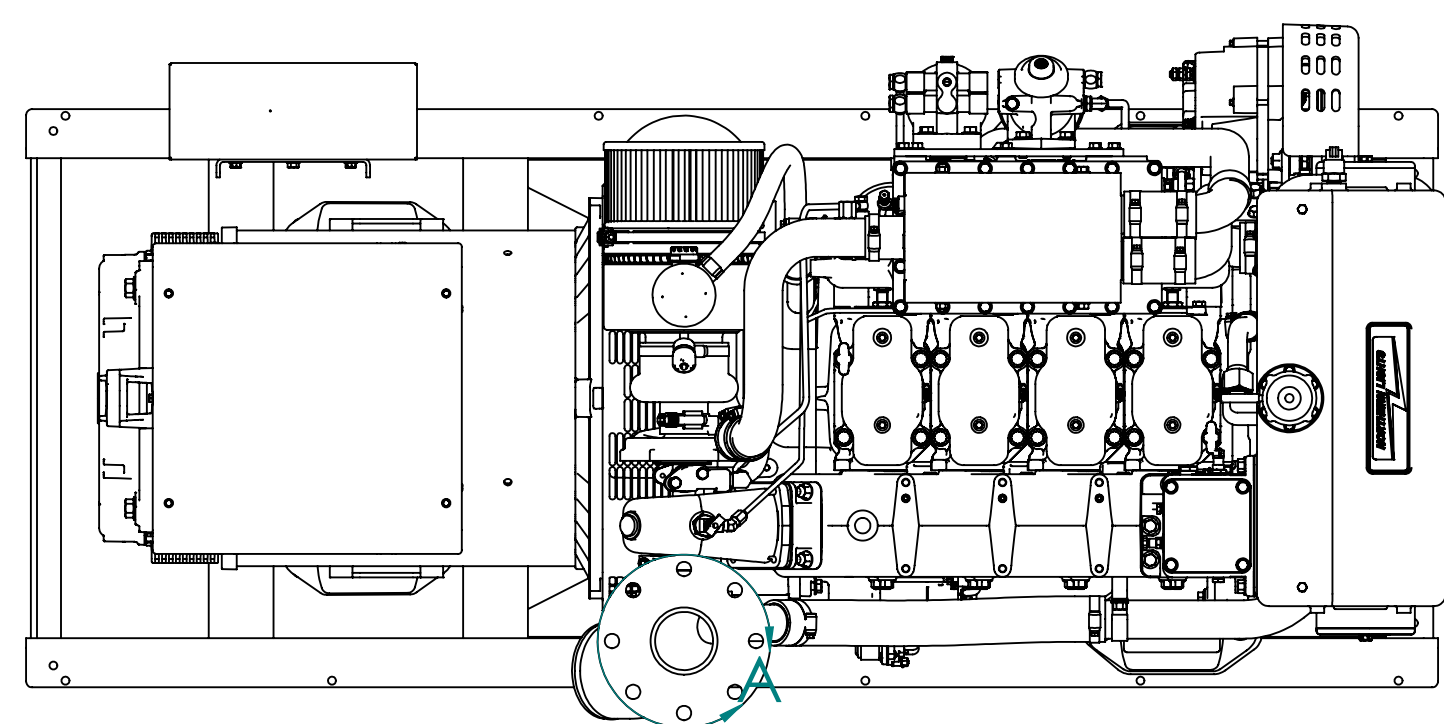

TOP

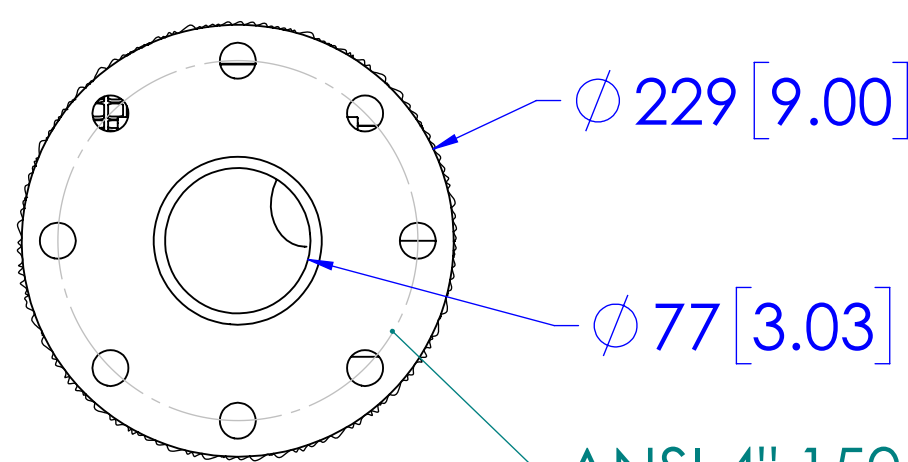

DETAIL A  
OPTIONAL DRY EXHAUST FLANGE  
SCALE 1 : 4

ANSI 4" 150# FLANGE  
8 x Ø .75" THRU ON 7.5" B.C.

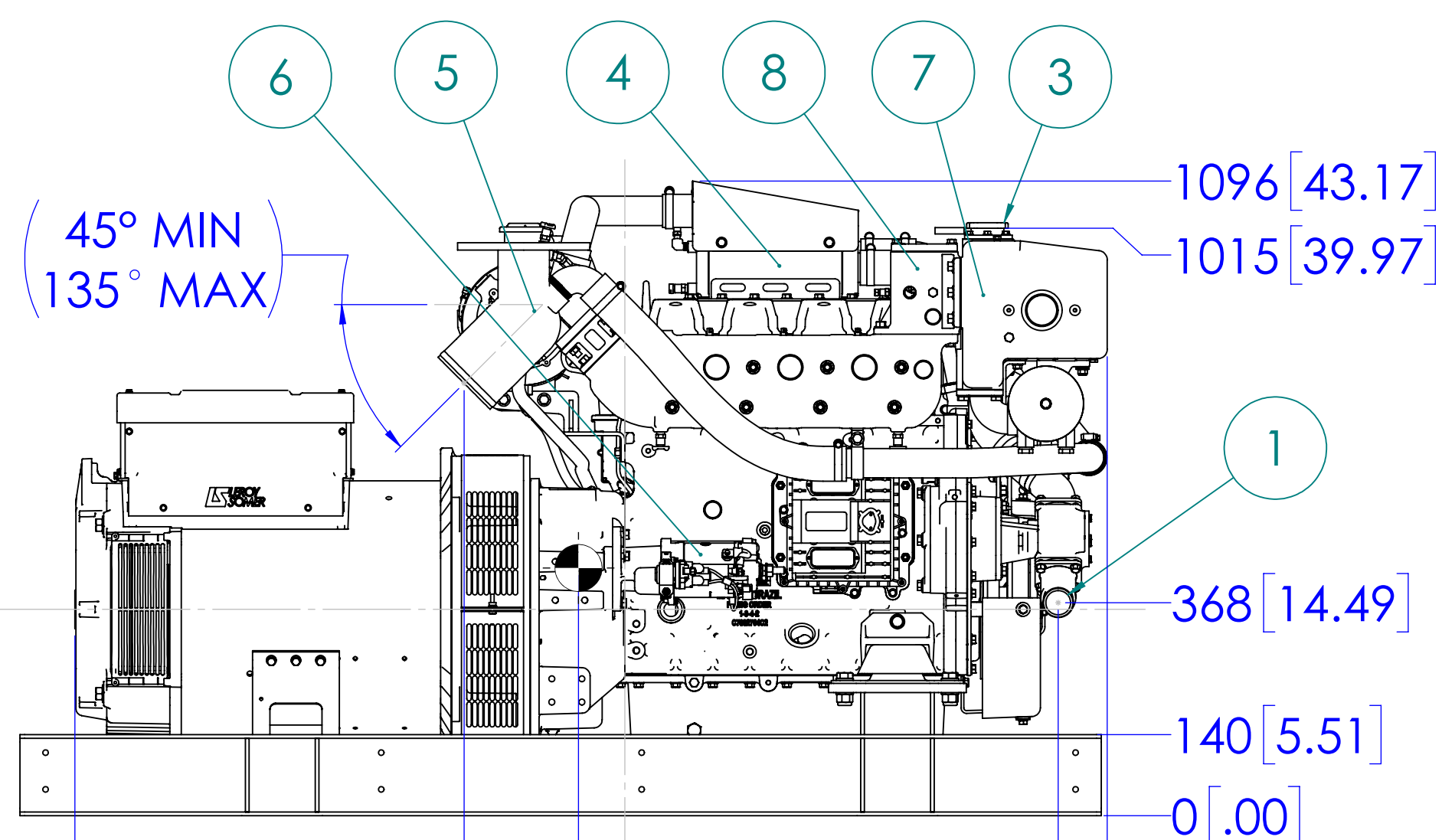

LEFT SIDE

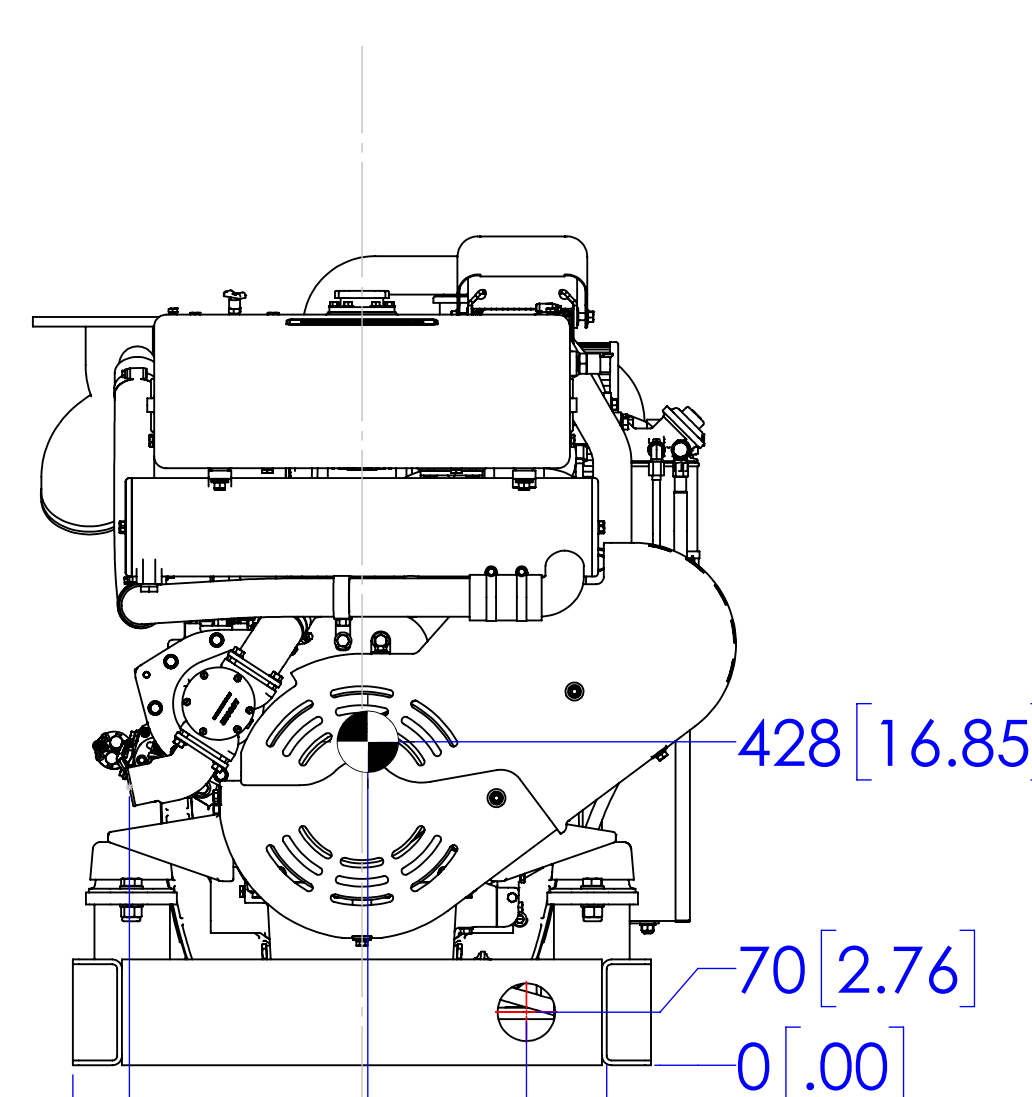

FRONT

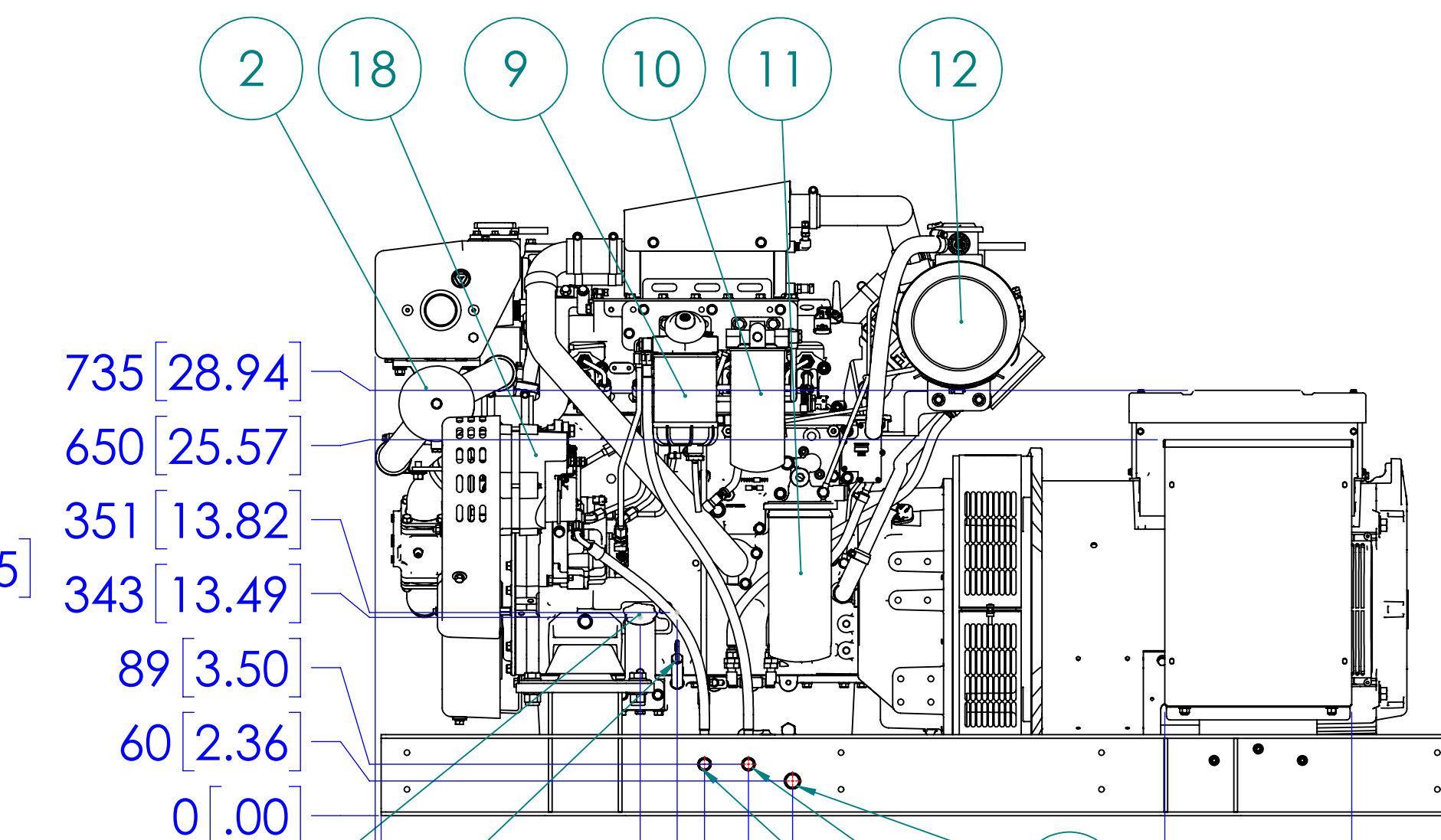

SERVICE SIDE

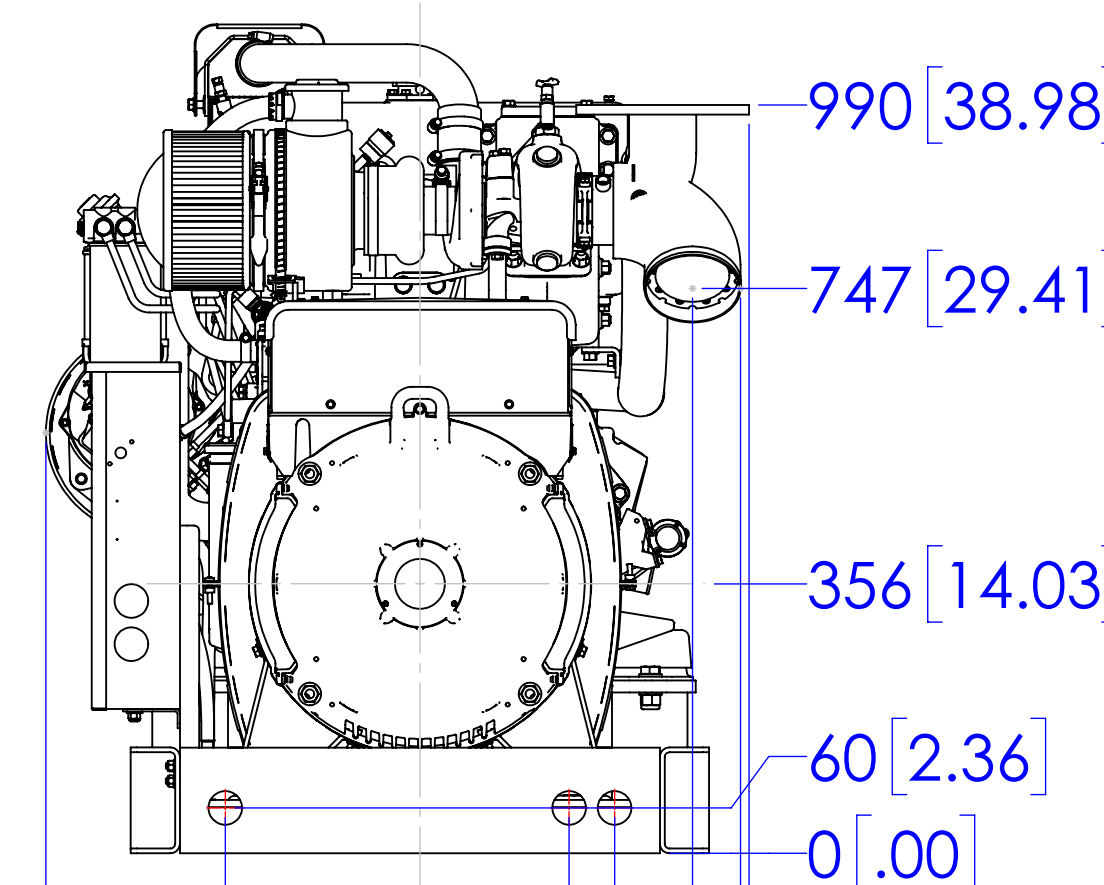

REAR

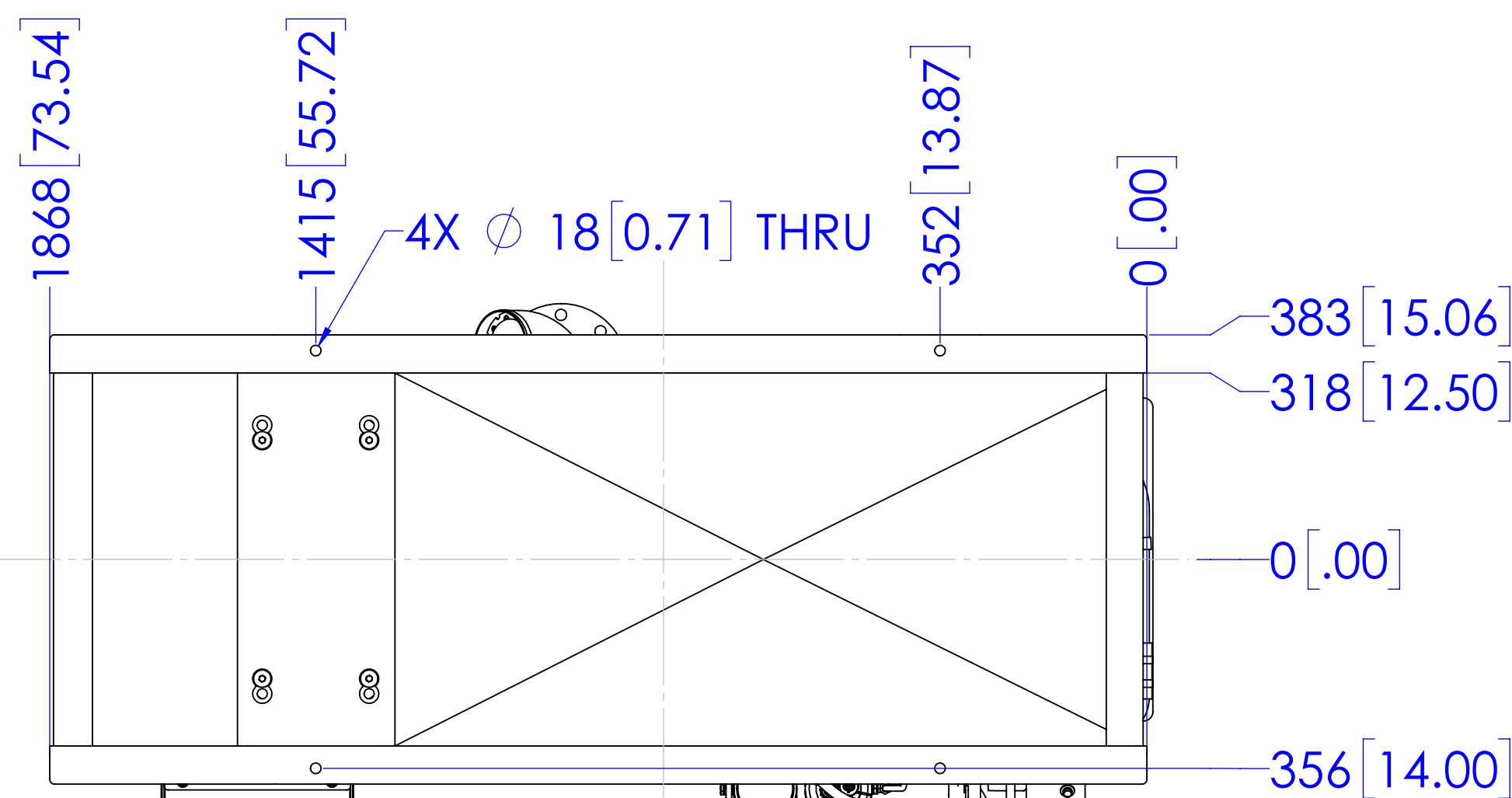

MOUNTING

THE DIMENSIONS ON THIS DRAWING ARE SUBJECT TO CHANGE. PLEASE CONTACT NLI TO BE SURE YOU HAVE THE MOST CURRENT REVISION.

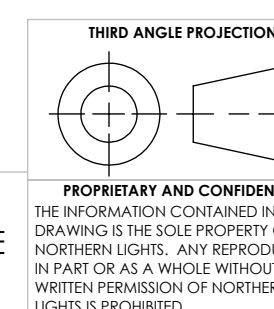

UNLESS OTHERWISE SPECIFIED:  
DIMENSIONS ARE IN MILLIMETERS  
TOLERANCES:  
ANGULAR: MACH ± 0.5° BEND ± 1.0°  
X ± 0.5  
XX ± 0.3  
INTERPRET GEOMETRIC TOLERANCING PER ASME Y14.5M  
MATERIAL:  
FINISH:  
DO NOT SCALE

NAME	DATE
JPW	5/8/2023

CHECKED  
ENG APPR.  
MEG APPR.  
G.A.  
COMMENTS:

**NORTHERN LIGHTS**  
4420 14th AVE. N.W.  
Seattle, WA 98107  
(206) 789-3880  
www.northern-lights.com

TITLE:  
INSTALLATION DIMENSIONS  
M4105A, 50HZ, HEAT EXCHANGED

SIZE	PART NO.	DWG. NO.	REV
D	SEE TABLE	D-5539	

SCALE: 1:10 WEIGHT: SHEET 1 OF 1

REV D D-5539