

MODEL	DESCRIPTION	APPROX. WT - LBS (KG)
L6105A1	255HP (190KW) @ 2100RPM, HEAT EXCHANGED	1773 (804)
L6105A2	315HP (235KW) @ 2250RPM, HEAT EXCHANGED	
L6105A3	380HP (283KW) @ 2500RPM, HEAT EXCHANGED	

\*NOTE: WEIGHTS INCLUDE OIL, BUT NO COOLANT. VALUES ARE APPROXIMATIONS AND ARE SUBJECT TO CHANGE. PLEASE CONTACT NLI TO BE SURE YOU HAVE THE MOST CURRENT REVISION.

ITEM	DESCRIPTION	ITEM	DESCRIPTION
1	SEA WATER INLET $\phi$ 51 [2.0] H.B.	14	ENGINE OIL FILL
2	HEAT EXCHANGER	15	FUEL RETURN PORT 3/8"-37T
3	COOLANT FILL	16	FUEL SUPPLY PORT 3/8"-37T
4	AFTERCOOLER	17	ENGINE OIL DRAIN PORT M22X1.5
5	WET EXHAUST ELBOW $\phi$ 127 [5.0]	18	ALTERNATOR
6	ELECTRIC STARTER MOTOR	19	VIBRATION MOUNTS (OPTIONAL)
7	EXPANSION TANK	20	DRY EXHAUST ELBOW (OPTIONAL)
8	THERMOSTAT HOUSING	21	
9	FUEL/WATER SEPARATOR	22	
10	FINAL FUEL FILTER	23	
11	OIL FILTER	24	
12	AIR FILTER & COALESCING FILTER	25	
13	ENGINE OIL DIPSTICK	26	

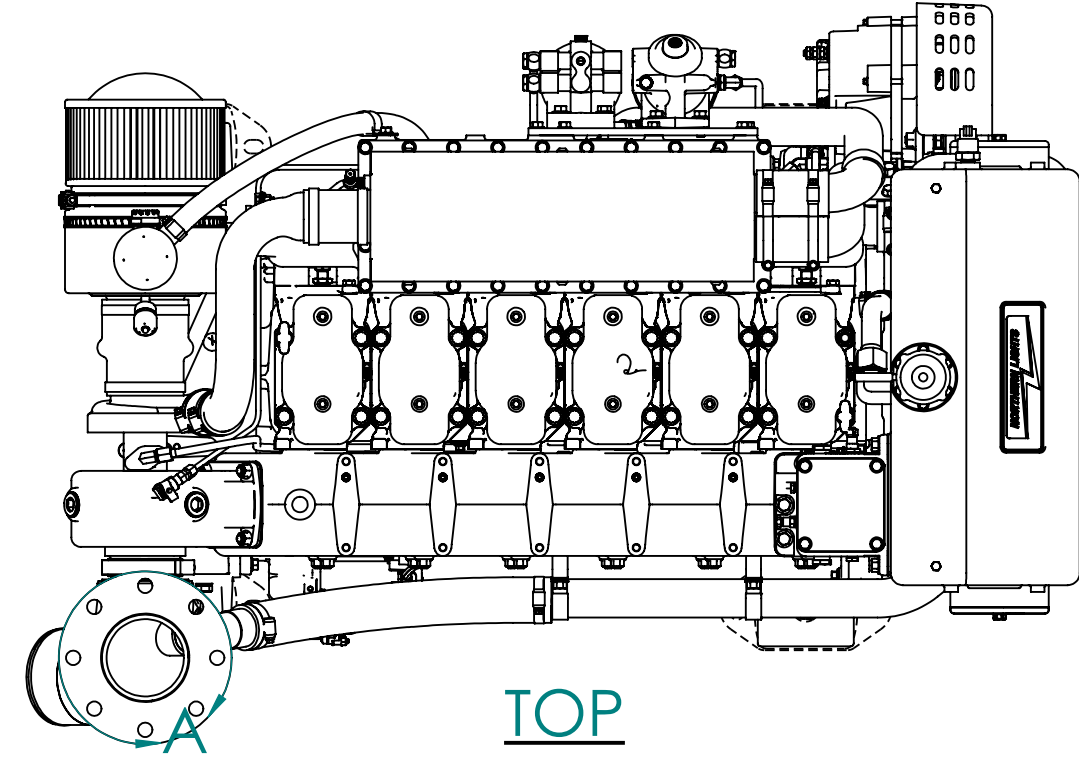

TOP



DETAIL A  
OPTIONAL DRY EXHAUST FLANGE  
SCALE 1 : 4

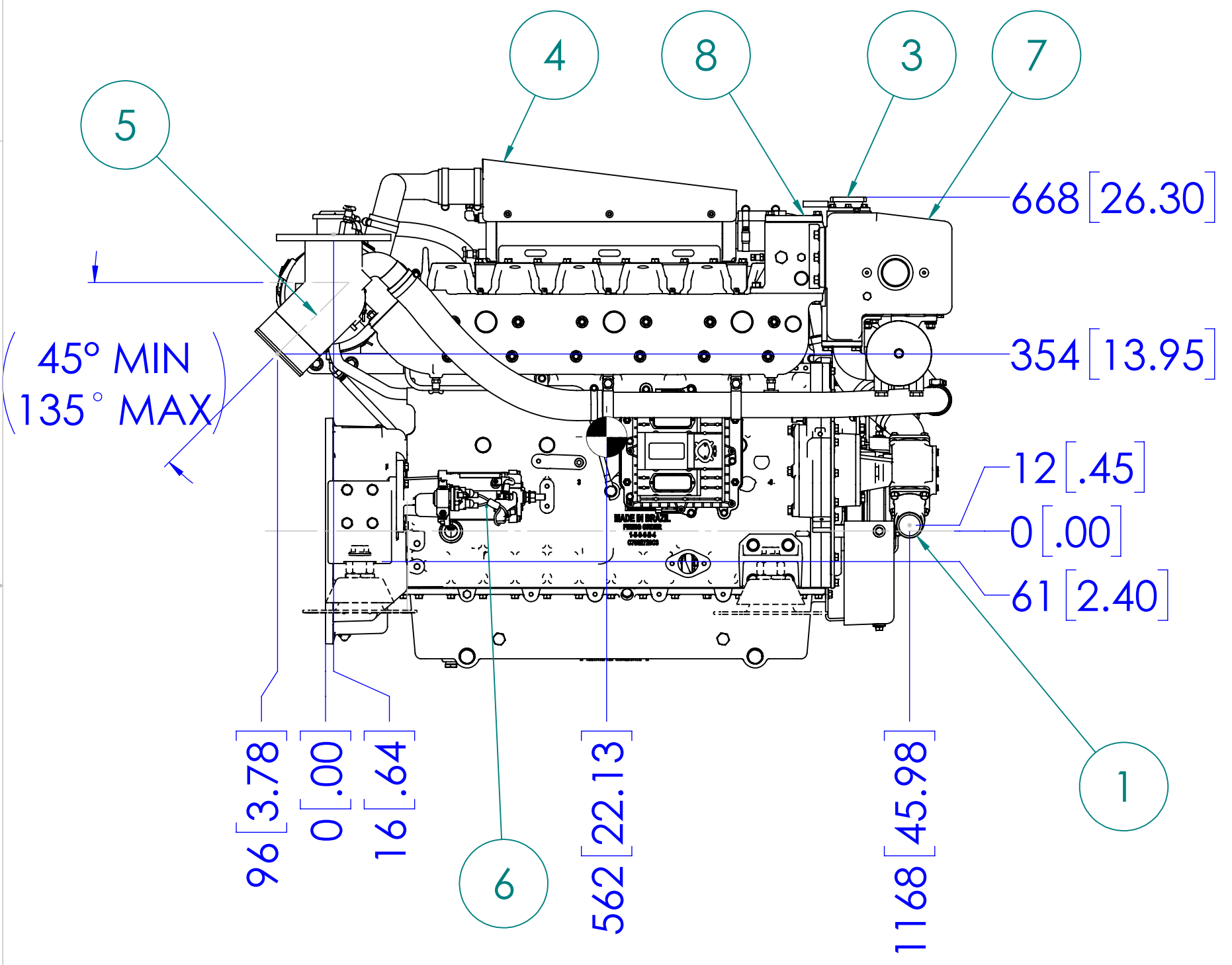

LEFT SIDE

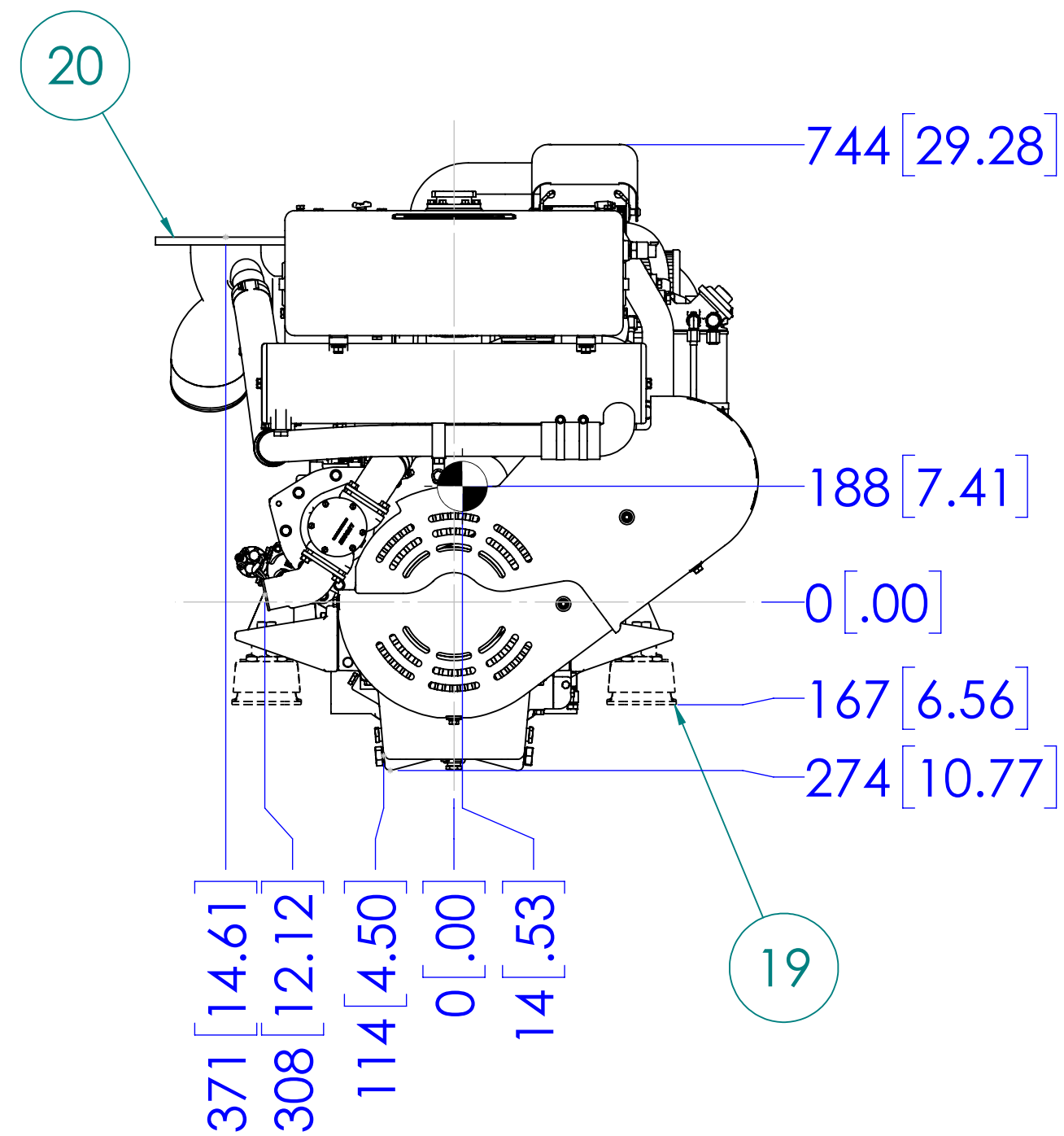

FRONT

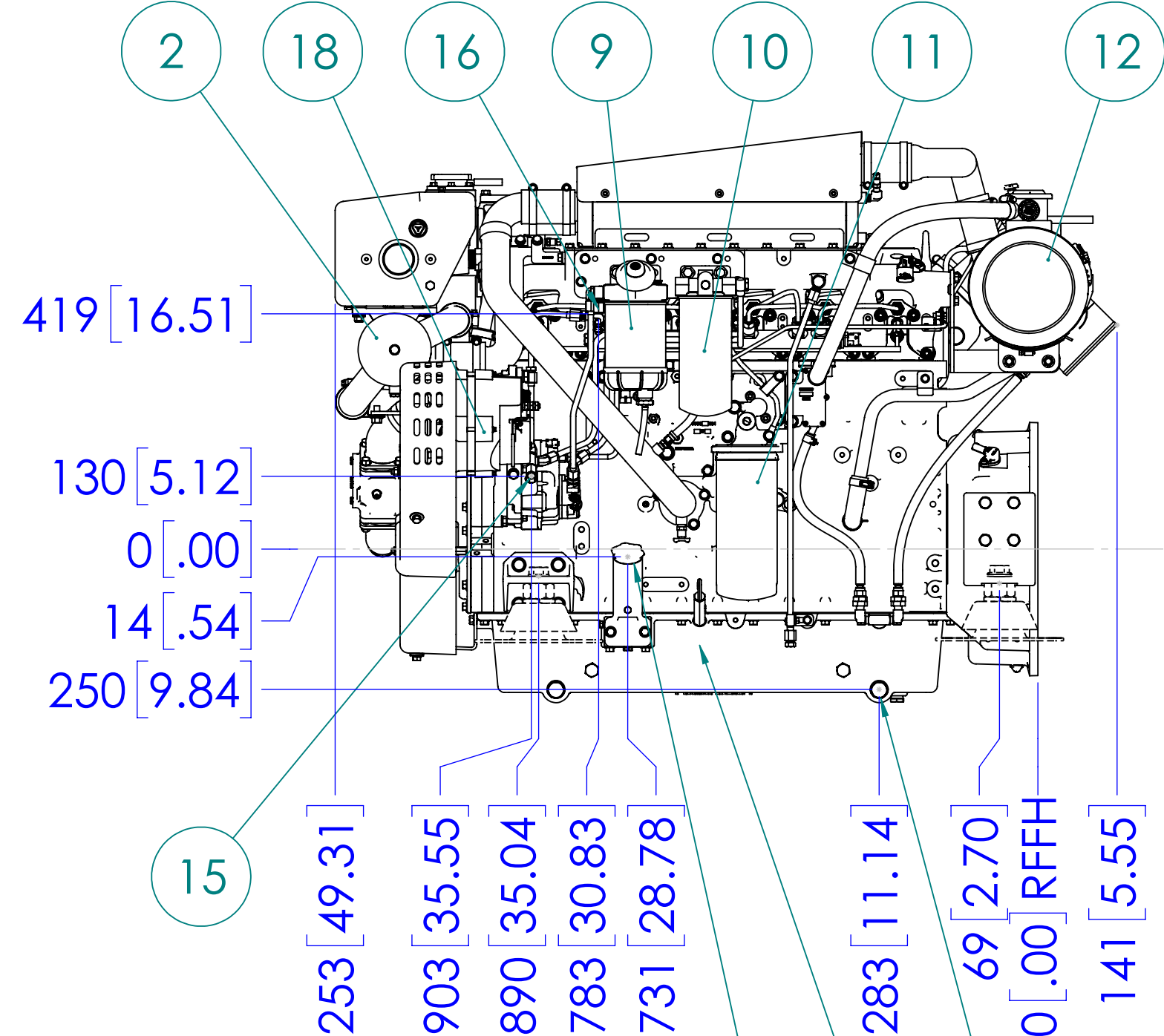

SERVICE SIDE

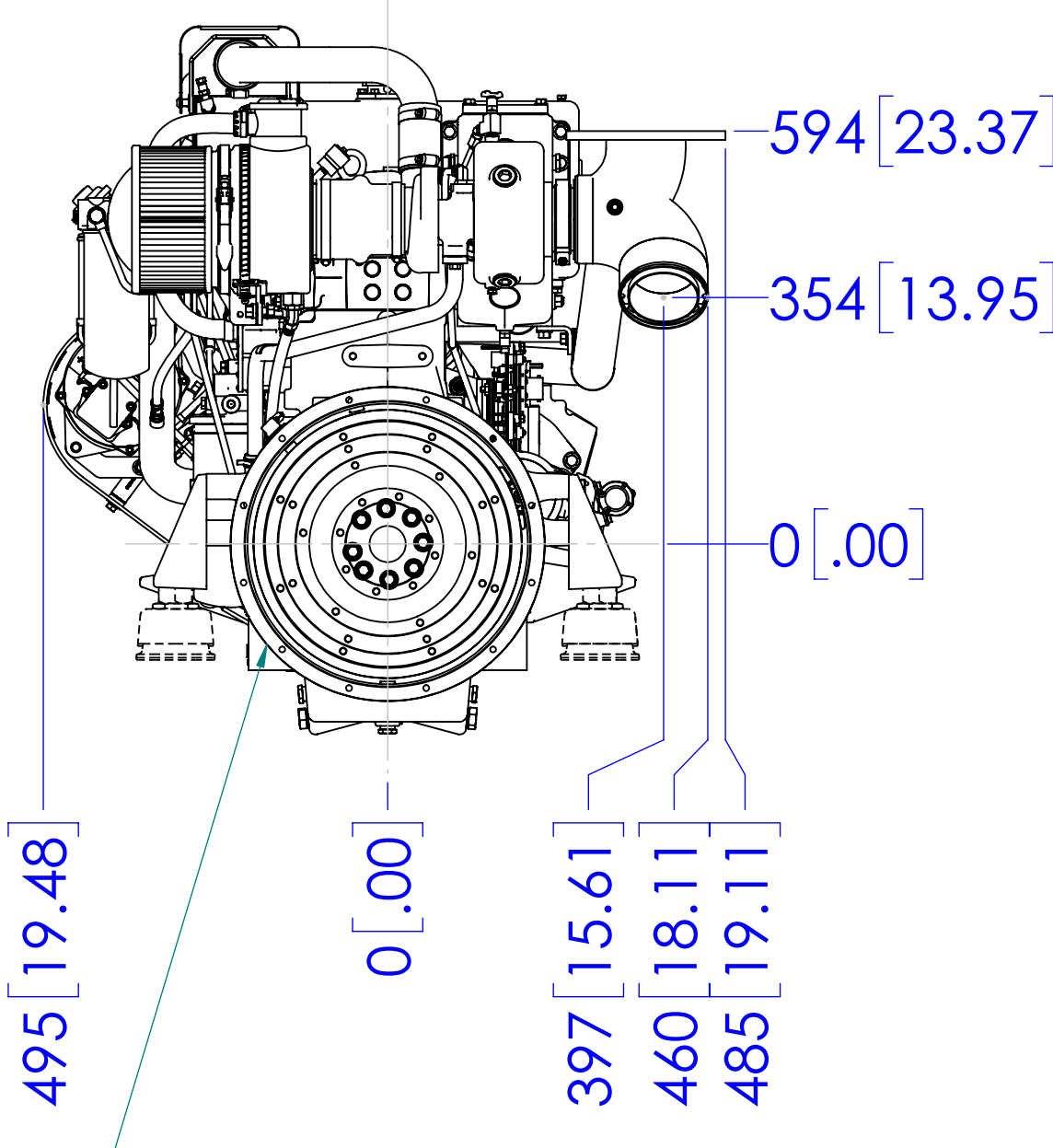

REAR

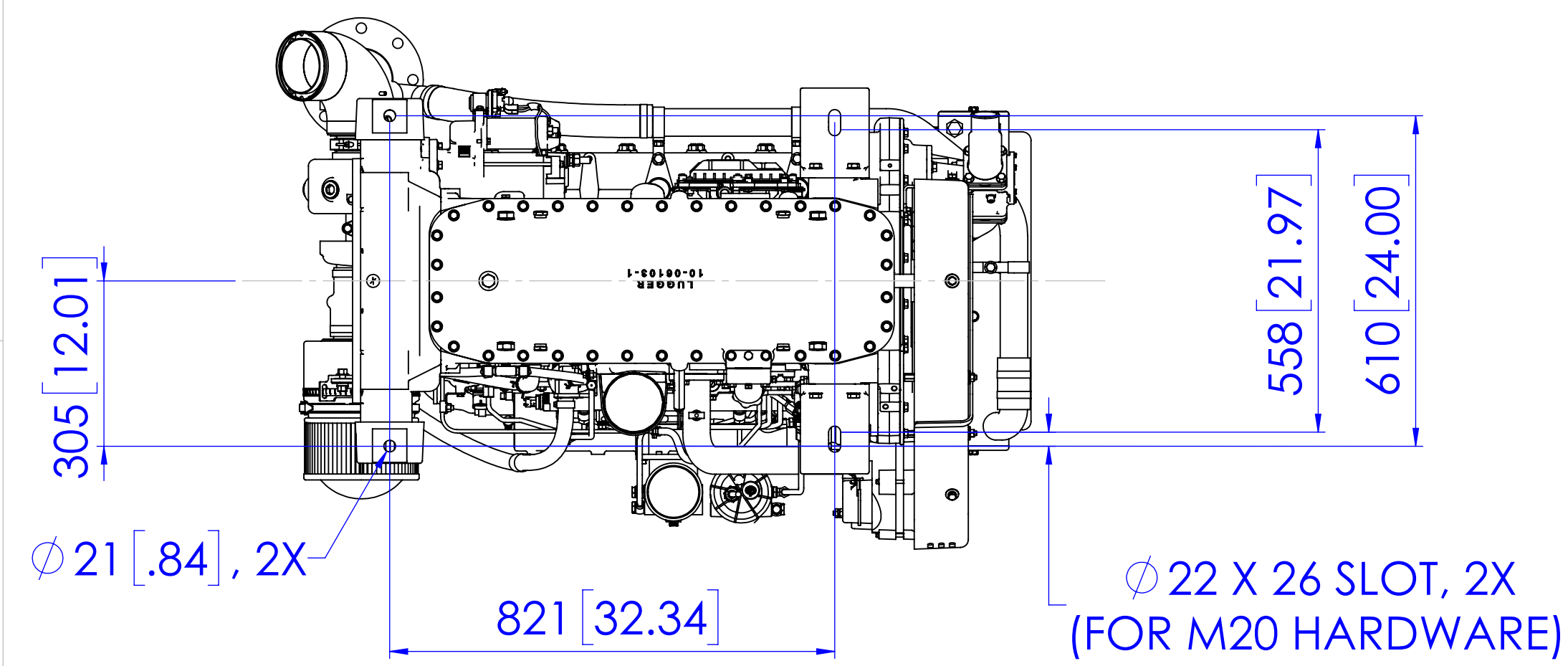

MOUNTING (W/O VIBRATION ISOLATION)

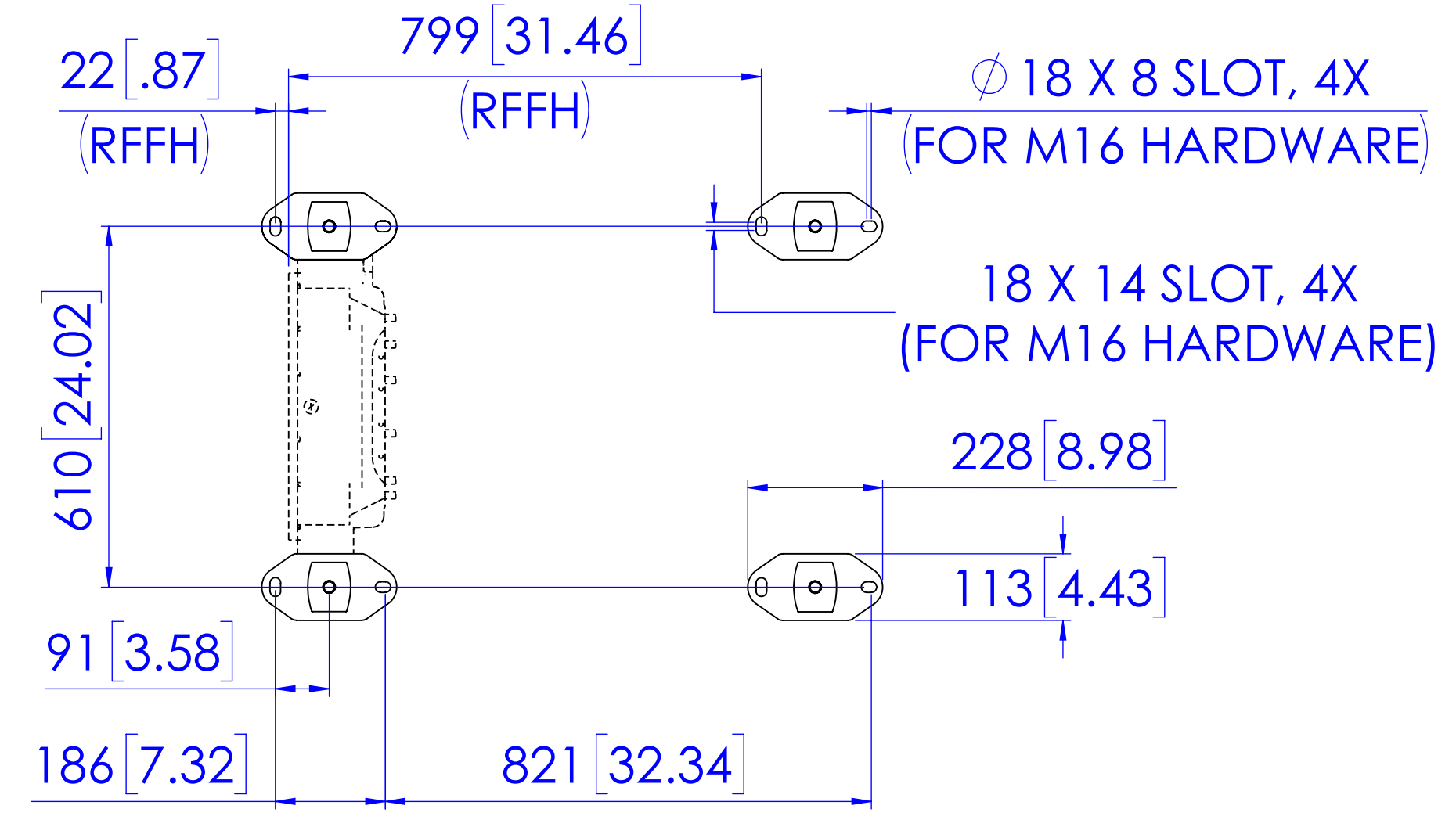

OPTIONAL VIBRATION ISOLATION FOOTPRINT

SAE #3  
11.5" FLYWHEEL

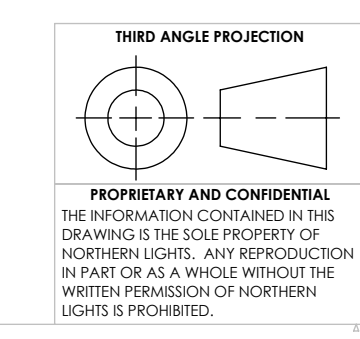

UNLESS OTHERWISE SPECIFIED:		NAME	DATE
DIMENSIONS ARE IN MILLIMETERS		JPW	12/29/23
TOLERANCES:		CHECKED	MG
ANGULAR:	MACH $\pm$ 0.5° BEND $\pm$ 1.0°	ENG APPR.	
X $\pm$ 0.5		MEG APPR.	
.XX $\pm$ 0.3		Q.A.	
INTERPRET GEOMETRIC TOLERANCING PER: ASME Y14.5M		COMMENTS:	
MATERIAL:			
FINISH:			
DO NOT SCALE			

**NORTHERN LIGHTS** 4420 14th AVE. N.W. Seattle, WA 98107 (206) 789-3880 www.northern-lights.com

TITLE: INSTALLATION DIMENSIONS (BOBTAIL) L6105A1 / L6105A2 / L6105A3

SIZE: **D** PART NO: L6105A DWG. NO: D-5585 REV

SCALE: 1:10 WEIGHT: SHEET 1 OF 1