

MODEL	DESCRIPTION	WEIGHT - LBS [KG]
L4105H1	270HP (201KW) @ 2400RPM, HEAT EXCHANGED	1391 [631]
L4105H2	300HP (224KW) @ 2500RPM, HEAT EXCHANGED	

*NOTE: WEIGHTS INCLUDE OIL, BUT NO COOLANT. WEIGHT DOES NOT INCLUDE OPTIONAL VIBRATION ISOLATORS. VALUES ARE APPROXIMATIONS AND ARE SUBJECT TO CHANGE. PLEASE CONTACT NLI TO BE SURE YOU HAVE THE MOST CURRENT REVISION.

ITEM	DESCRIPTION	ITEM	DESCRIPTION
1	SEA WATER INLET ϕ 51 [2.0] H.B.	14	ENGINE OIL FILL
2	HEAT EXCHANGER	15	FUEL RETURN PORT 3/8"-37T
3	COOLANT FILL	16	FUEL SUPPLY PORT 3/8"-37T
4	AFTERCOOLER	17	ENGINE OIL DRAIN PORT M22X1.5
5	WET EXHAUST ELBOW ϕ 127 [5.0]	18	ALTERNATOR
6	ELECTRIC STARTER MOTOR	19	VIBRATION MOUNTS (OPTIONAL)
7	EXPANSION TANK	20	DRY EXHAUST ELBOW (OPTIONAL)
8	THERMOSTAT HOUSING	21	
9	FUEL/WATER SEPARATOR	22	
10	PRIMARY FUEL FILTER	23	
11	OIL FILTER	24	
12	AIR FILTER & COALESCING FILTER	25	
13	ENGINE OIL DIPSTICK	26	

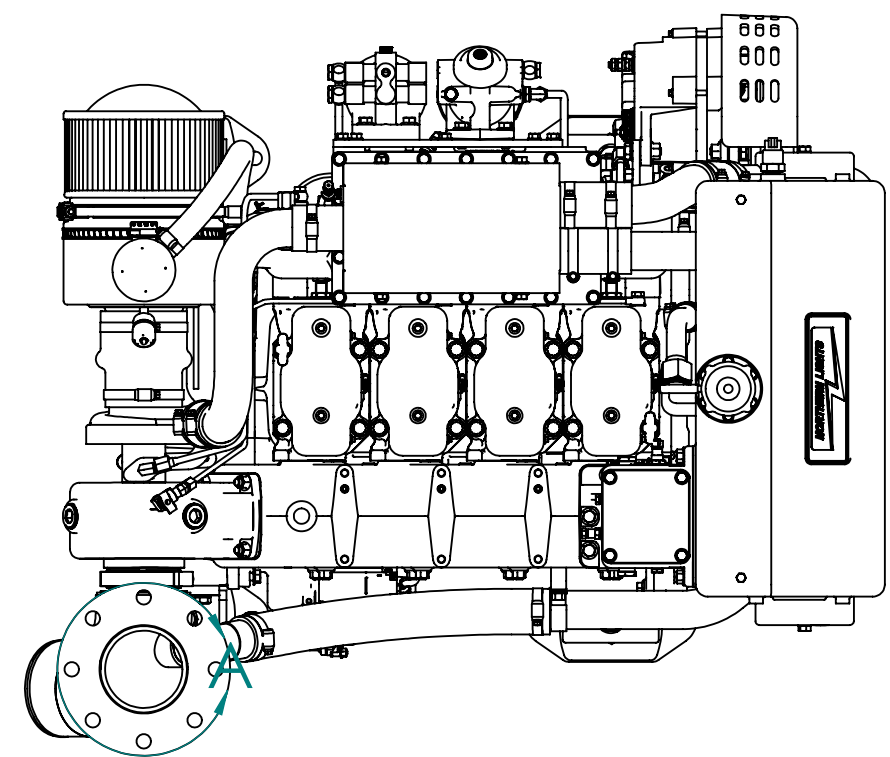

TOP

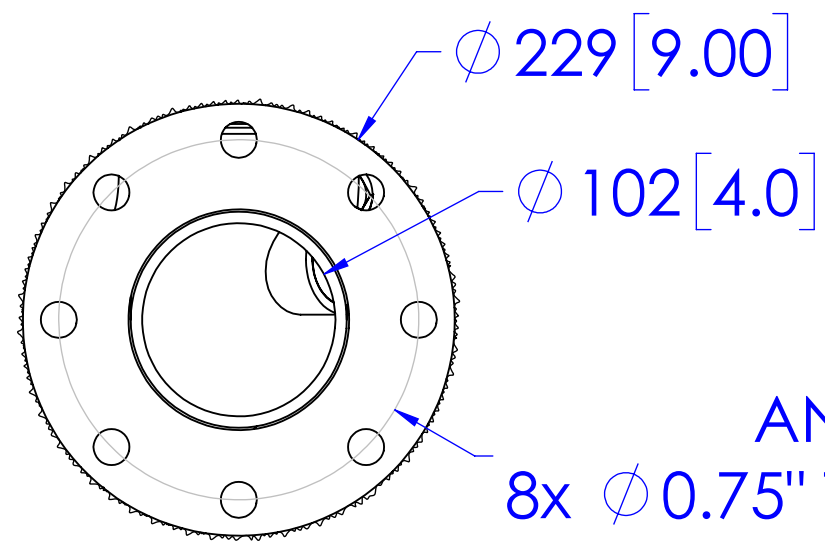

ANSI 4" 150# FLANGE
8x ϕ 0.75" THRU HOLES ON ϕ 7.5" B.C.

DETAIL A
OPTIONAL DRY EXHAUST FLANGE
SCALE 1 : 4

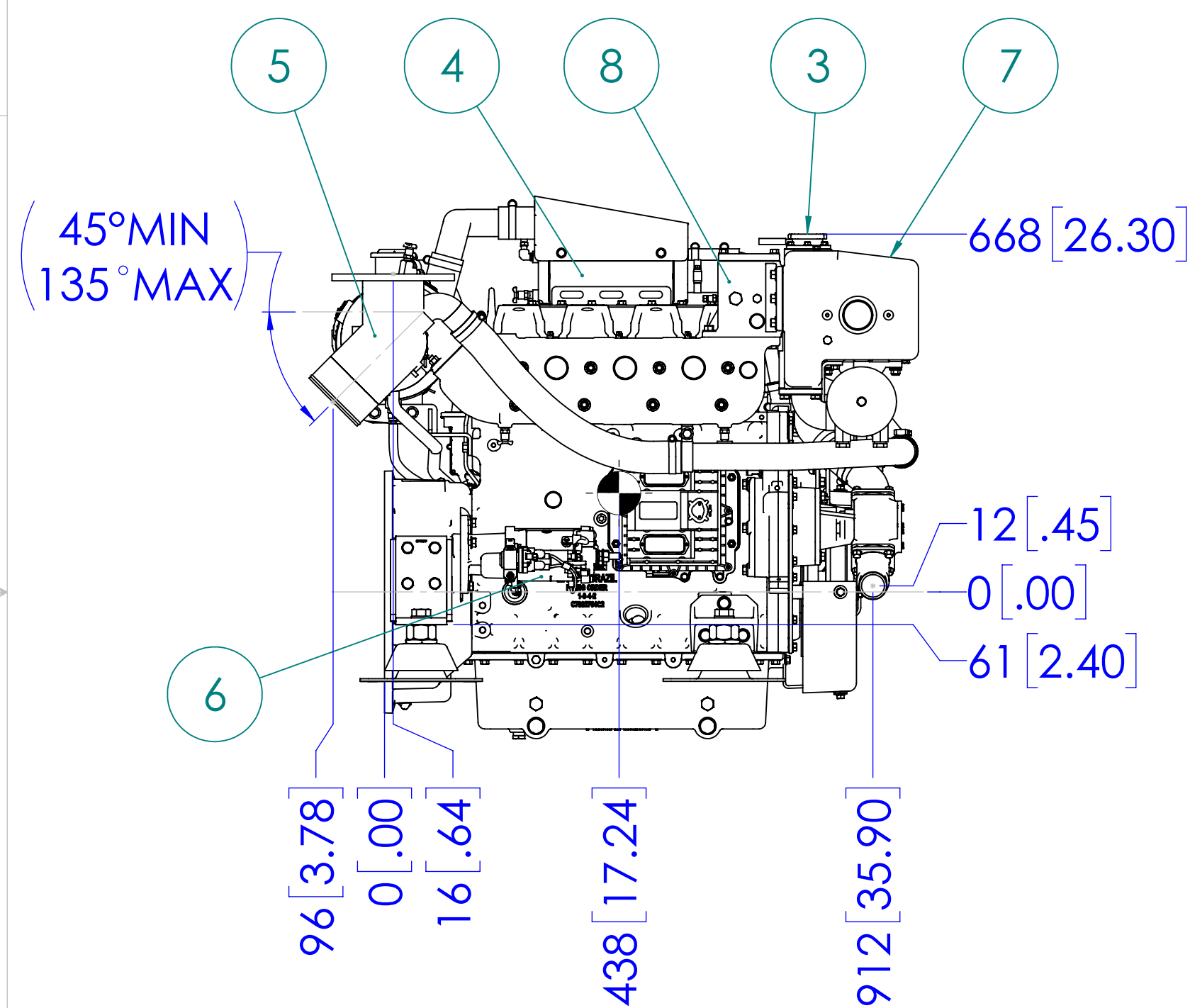

LEFT SIDE

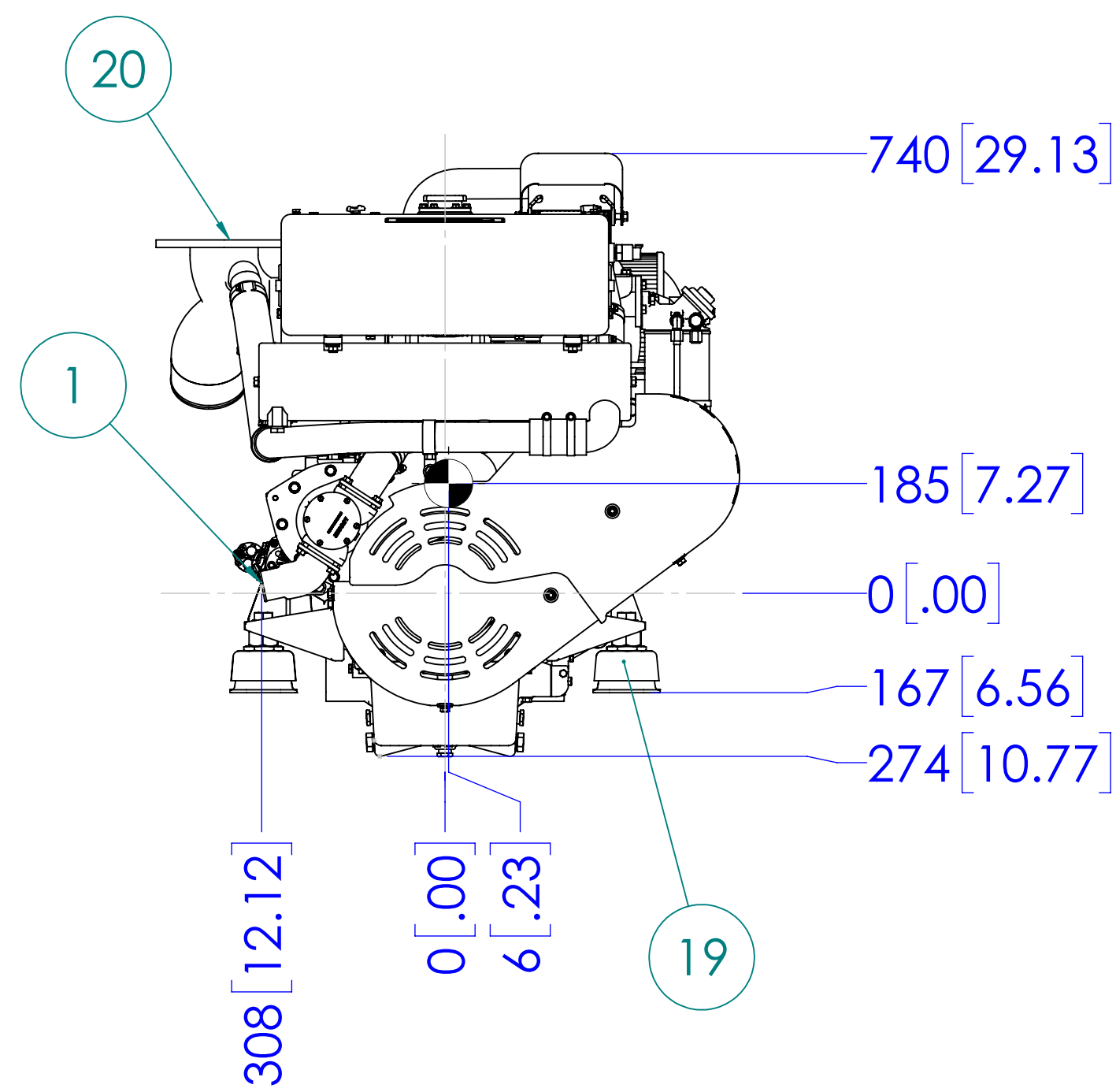

FRONT

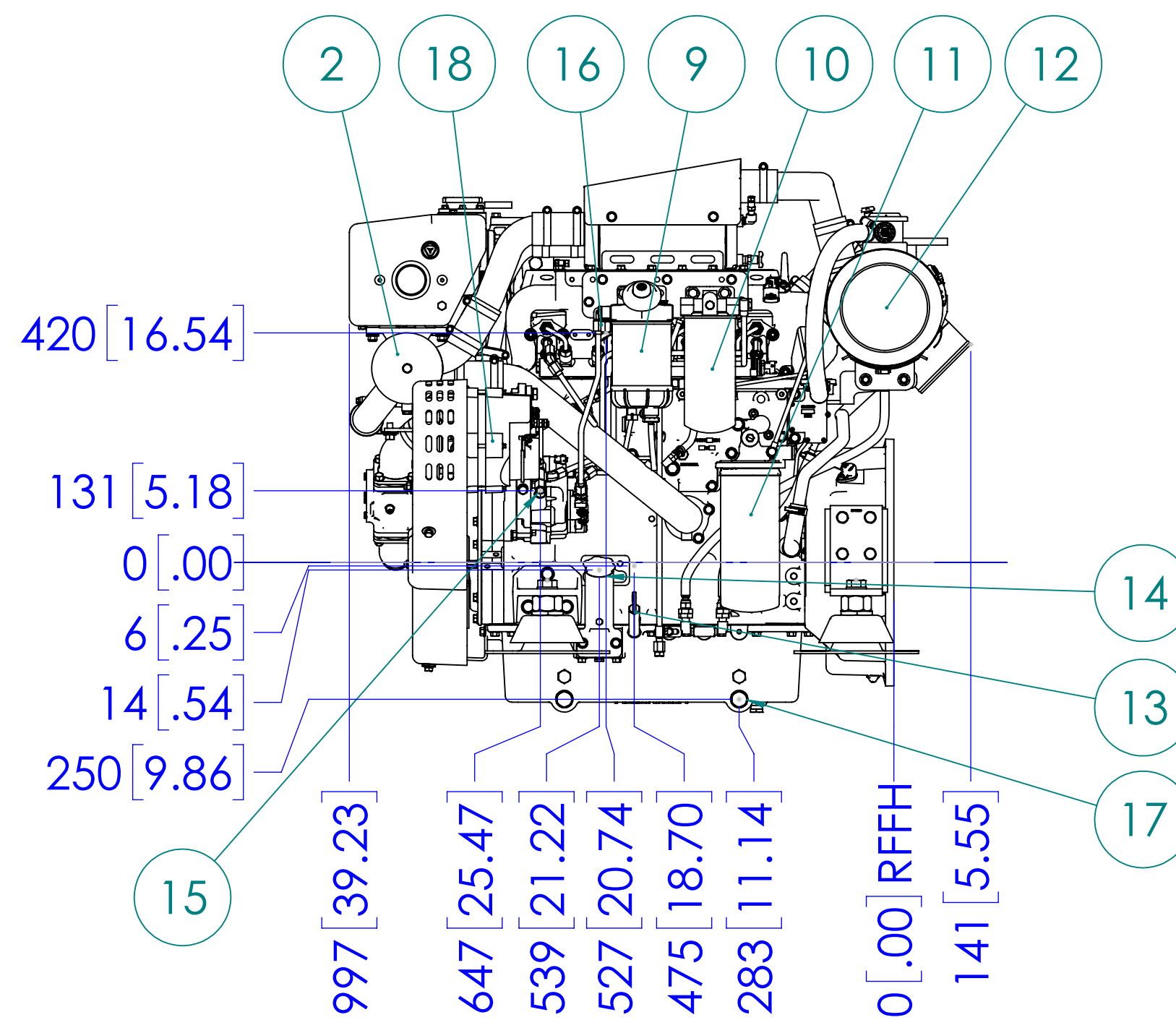

SERVICE SIDE

SAE #3
11.5" FLYWHEEL

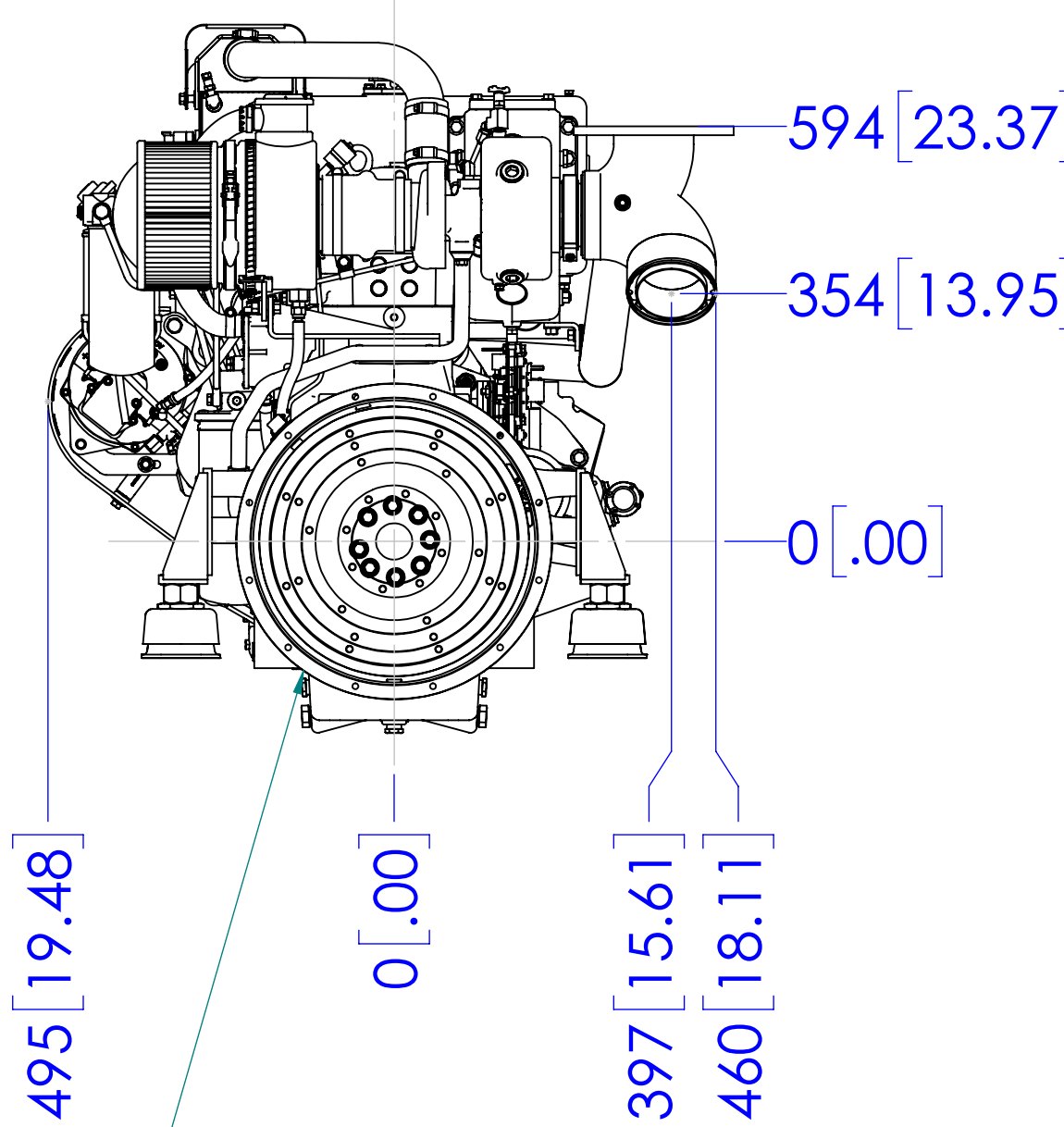

REAR

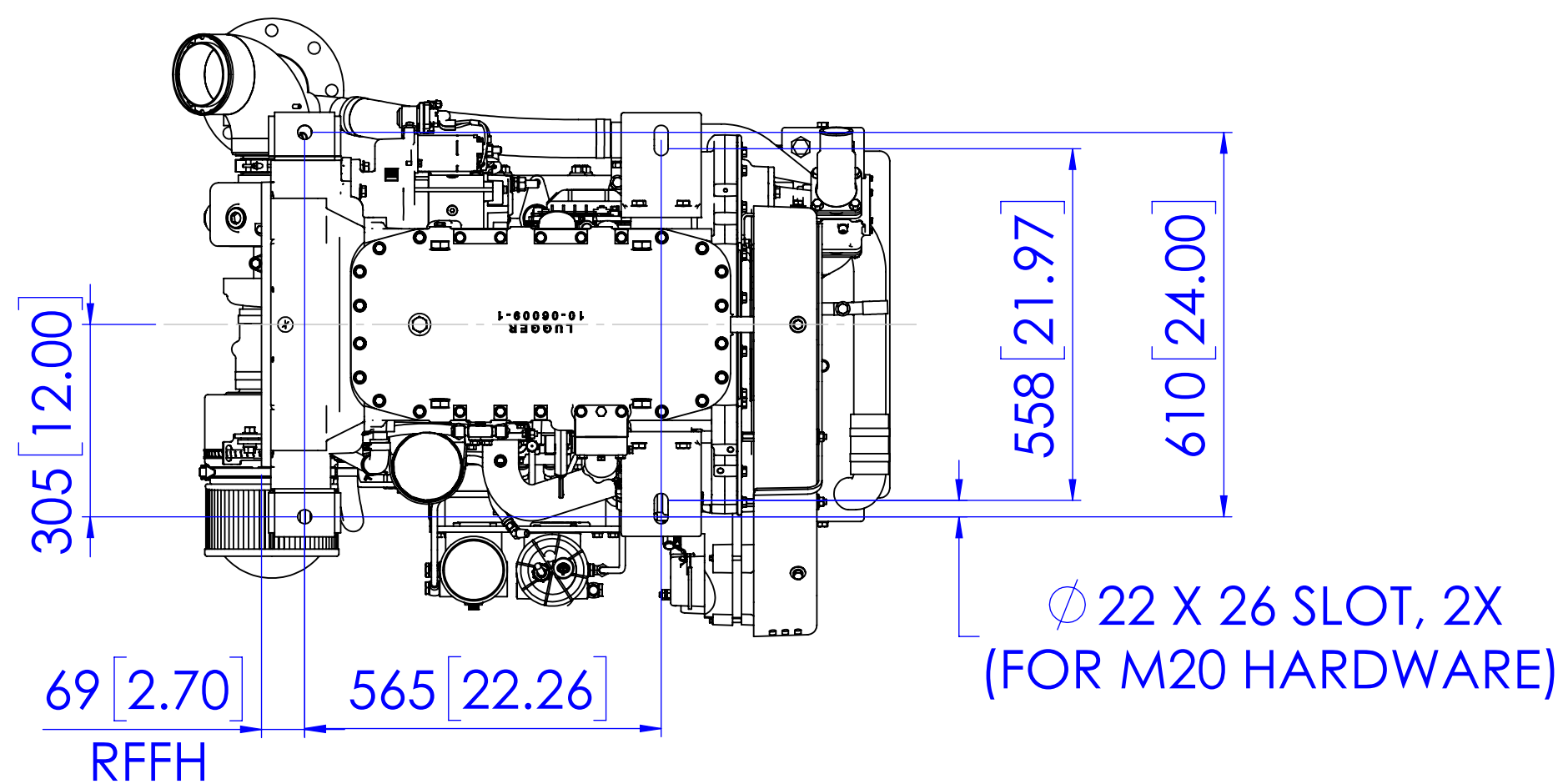

MOUNTING (W/O VIBRATION ISOLATION)

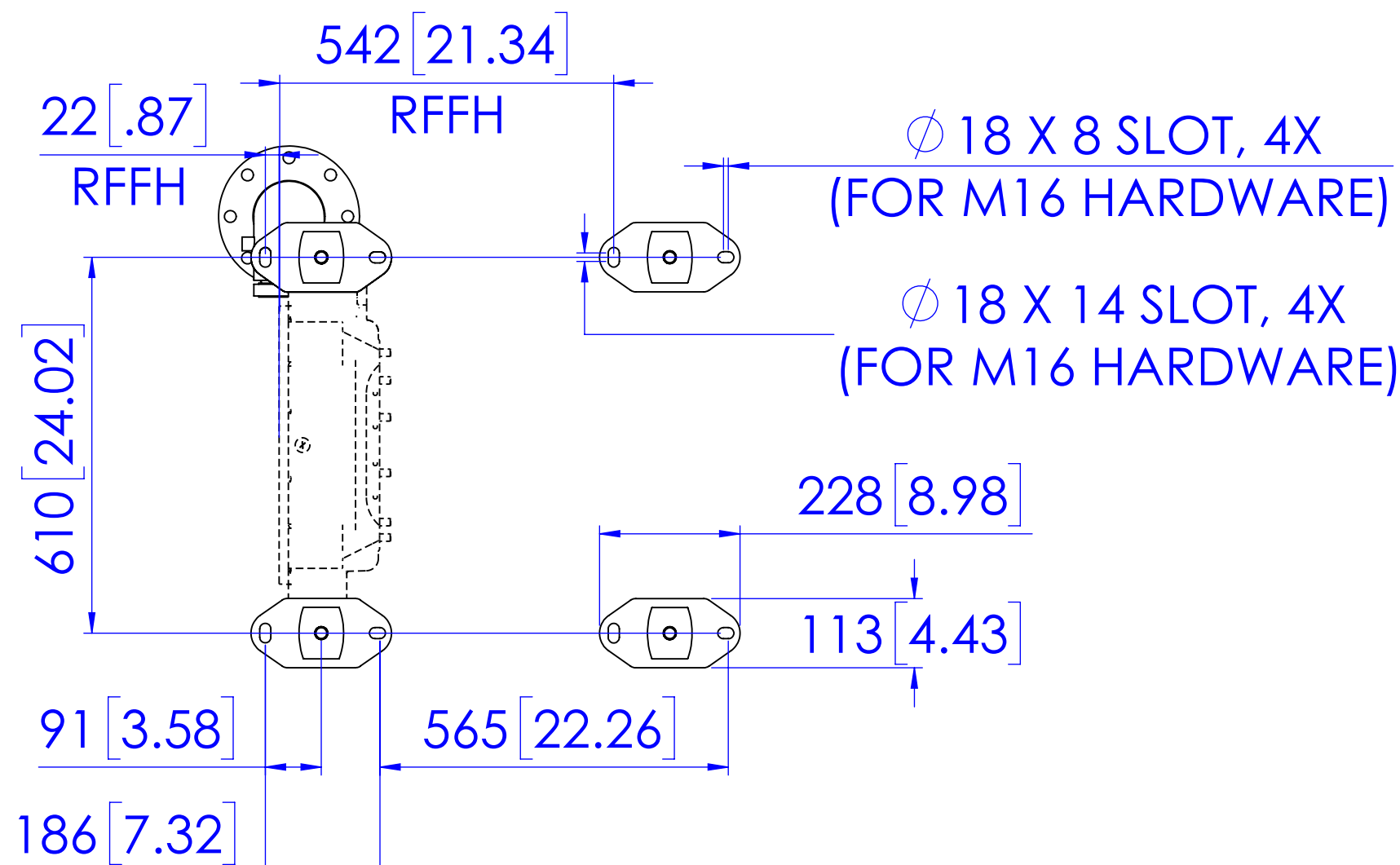

OPTIONAL VIBRATION ISOLATION FOOTPRINT

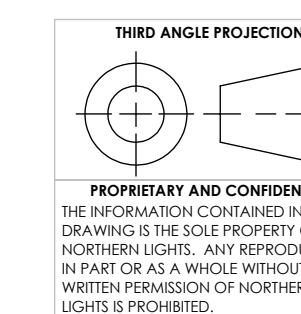

UNLESS OTHERWISE SPECIFIED:		NAME	DATE
DIMENSIONS ARE IN MILLIMETERS		JPW	7/23/2024
TOLERANCES:		CHECKED	
ANGULAR: MACH \pm 0.5° BEND \pm 1.0°		ENG APPR.	
X \pm 0.5		MEG APPR.	
.XX \pm 0.3		Q.A.	
INTERPRET GEOMETRIC TOLERANCING PER: ASME Y14.5M		COMMENTS:	
MATERIAL:			
FINISH:			
DO NOT SCALE			



TITLE: INSTALLATION DIMENSIONS L4105H1, L4105H2			
SIZE: D	PART NO: SEE TABLE	DWG. NO: D-5604	REV
SCALE: 1:10	WEIGHT:	SHEET 1 OF 1	